

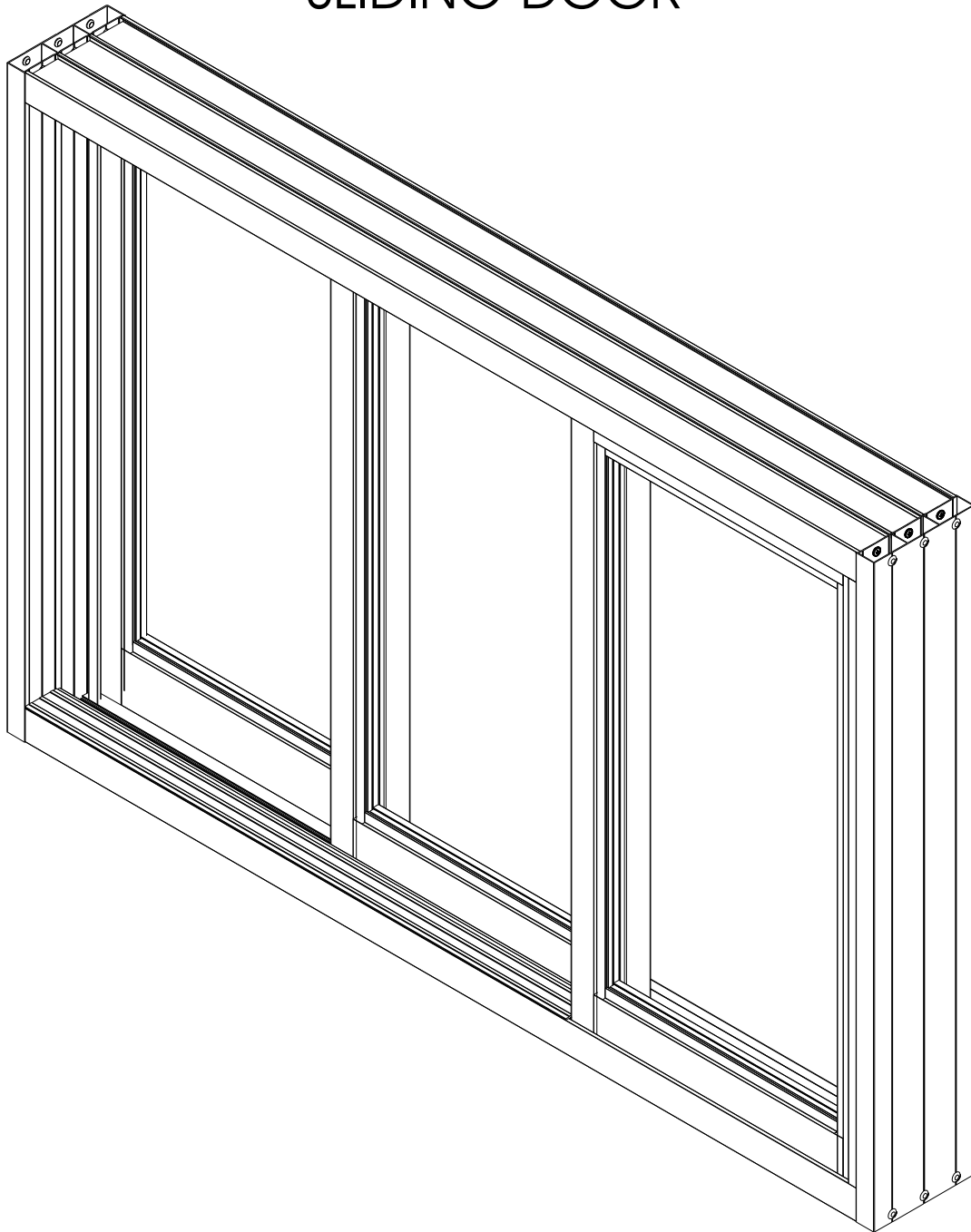

crealco

PALACE

PALACE HIGH PERFORMANCE SLIDING DOOR



PRODUCT MANUAL

Disclaimer: The right to make alterations is reserved
© 2013 Wispeco (Pty) Ltd, All Rights Reserved
Revision: June 2013



crealco

PALACE

Index

Legal Disclaimer	4
Profile Identification	5-7
Hardware Identification	8
Double Track Configurations	9
Triple Track Configurations	10
Fixing Details	11
Cross Sectional Detail OX Configuration	12
Cross Sectional Detail 2 Panel Multi Slider Configuration	13
Cross Sectional Detail OXXO Configuration	14
Cross Sectional Detail 4 Panel Multi Slider Configuration	15
Cross Sectional Detail OXX Configuration	16
Cross Sectional Detail 3 Panel Multi Slider Configuration	17
Cross Sectional Detail OXXXXO Configuration	18
Cross Sectional Detail 6 Panel Multi Slider Configuration	19
Outer Frame Component Assembly Detail Double Track	20
Outer Frame Component Assembly Detail Triple Track	21
Insert Component Assembly Detail Sliding/Fixed	22
Insert Component Assembly Detail Sliding/Sliding	23
Cutting Detail <W55424>	24
Draught Excluders 2 & 4 Pane Sliders	25
Sash Block 2 & 4 Pane Sliders	26
Draught Excluders 3 & 6 Pane Multi Sliders	27-29
Detail Showing <ROLL911SS> Against Door Jamb Lip	30
Double Sill Floor Level Detail	31
Triple Sill Floor Level Detail	32
Double Jamb Machining Detail	33
Triple Jamb Machining Detail	34
Sill Cover Machining Detail	35
Triple Jamb Adaptor Machining Detail	36
Head/Sill Rail Machining Detail To Suit All Combinations	37
Sill Combinations	38
Midrail Machining Detail To Suit All Combinations	39
R4 Filler Adaptor Machining Detail	40

This manual must be read in conjunction with the Installation, Cleaning and Maintenance Document, BEE Certificates and the Performance Certificates for the relevant system. The manual must also be used in conjunction with the design and cutting list from the latest version of StarFront.

Disclaimer: The right to make alterations is reserved

© 2012 Wispeco (Pty) Ltd, All Rights Reserved

PAGE 2



crealco

PALACE

Index

Fixed Interlocker Machining Detail	42
Sliding Interlocker Machining Detail	43
Fixed Heavy Duty Interlocker Machining Detail	44
Sliding Heavy Duty Interlocker Machining Detail	45
90m Fixed Interlocker Machining Detail	46
Sliding Interlocker Machining Detail	47
Astragal Machining Detail	48
Heavy Duty Astragal Machining Detail For OX; OXXO & OXXXO	49
Heavy Duty Astragal Machining Detail For XX; XXX; XXXX; XXXXXXX	50
Spigot Machining Detail	51
Handle Machining Detail	52
Lock Machining Detail On Meeting Stile	53
Lock Machining Detail On Door Stile To Suit All Combinations	54
Roller Assembly Detail	55
Roller Assembly Detail On Multi Slider	56
Rod & Spigot Assembly Detail	57
Stopper Assembly Detail For OX, XXX, OXXXXO & XXXXXX	58
AAMSA Test	59
Setting Block Location	60

This manual must be read in conjunction with the Installation, Cleaning and Maintenance Document, BEE Certificates and the Performance Certificates for the relevant system. The manual must also be used in conjunction with the design and cutting list from the latest version of StarFront.

Disclaimer: The right to make alterations is reserved

© 2012 Wispeco (Pty) Ltd, All Rights Reserved

PAGE 3



crealco

PALACE

LEGAL DISCLAIMER

All information, recommendations or advice contained in this documentation is given in good faith to the best of Wispeco's knowledge and is based on current procedures in effect.

Since the actual use of this documentation by the user is beyond the control of Wispeco, such use is within the exclusive responsibility of the user. Wispeco cannot be held responsible for any loss incurred through incorrect or faulty use of this documentation.

Great care has been taken to ensure that the information provided is correct. Wispeco will accept no responsibility for any errors and/or omissions, which may have inadvertently occurred.

All mechanical joints must be sealed with a Wispeco approved joint sealer.

Laminated glass must not stand in water.

All drawings in the Wispeco Documentation are shown NOT to scale.

Wispeco cannot accept responsibility for the use of standard products since Wispeco does not know where these products are being installed.

The use of anti-magnetic stainless steel screws and pop rivets is recommended to reduce galvanic corrosion in harsh environments.

The hardware recommended in this documentation is suitable for use in most atmospheric environments. When hardware is used in severe coastal environments the manufacturer of the hardware must be consulted.

Fixing lugs on frames must be positioned as per the user manual and used in accordance to the AAAMSA specifications. When profiles are screwed together the screw centers must also be according to the user manual.

All glass used within Wispeco products must comply with SAGGA regulations.

All glazing above 10m from ground level must be signed off by a competent person (Glazing) in accordance with the national building regulations

By continuing to use this documentation you acknowledge that you understand and accept the legal disclaimer.

PALACE HIGH PERFORMANCE SLIDING DOOR PROFILE IDENTIFICATION

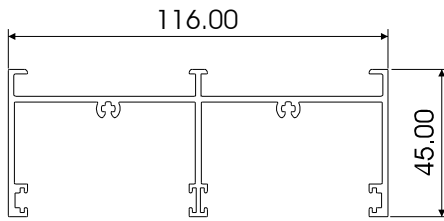

DOUBLE HEAD RAIL
W31533

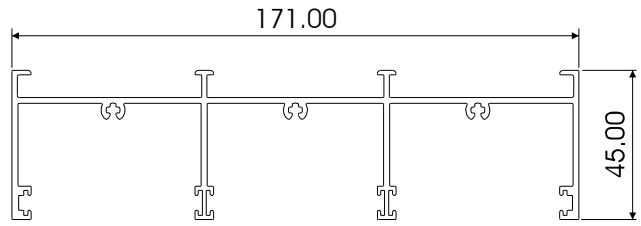

TRIPLE HEAD RAIL
W31537

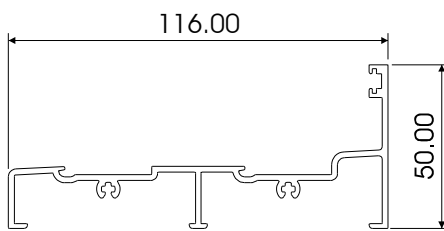

DOUBLE SILL
W31539

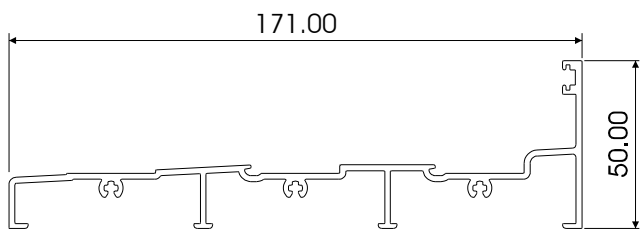

TRIPLE SILL RAIL
W31535

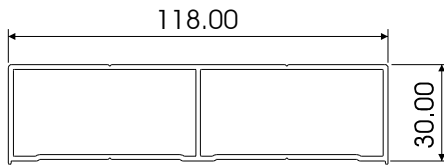

DOUBLE BOX JAMB
W55433

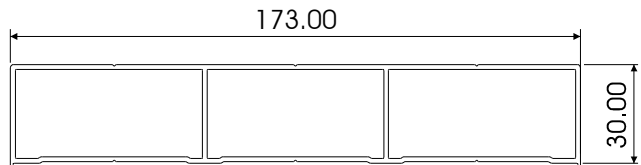

TRIPLE BOX JAMB
W55434

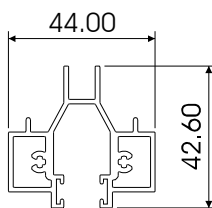

SILL EXTENTION
W55424

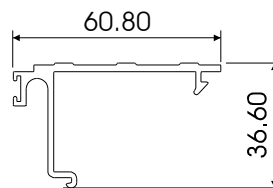

SILL COVER
W31538

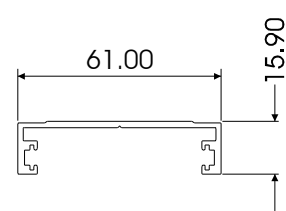

JAMB ADAPTOR
W31590

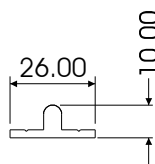

FLOOR TRACK
W26282

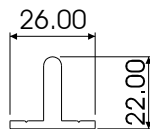

EXTENDED TRACK
W31594

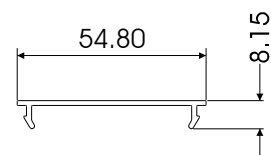

DOUBLE HEAD COVER
W31534

PALACE HIGH PERFORMANCE SLIDING DOOR PROFILE IDENTIFICATION

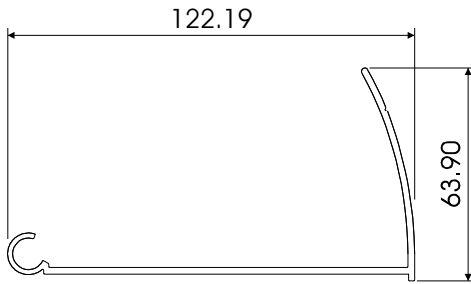

ADJUSTABLE CORNER 1
W29636

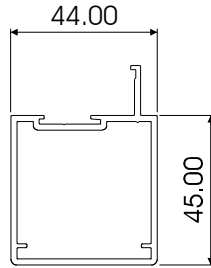

R1 DOOR JAMB
W44085

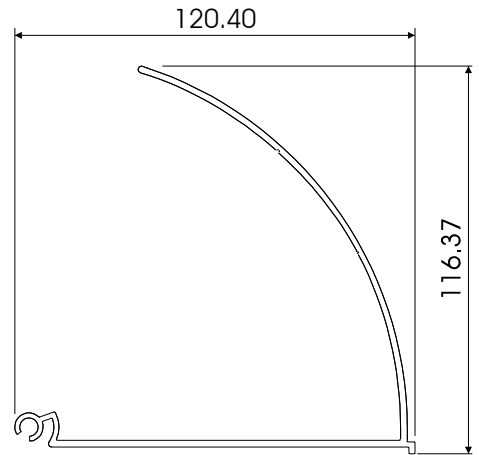

ADJUSTABLE CORNER 2
W29637

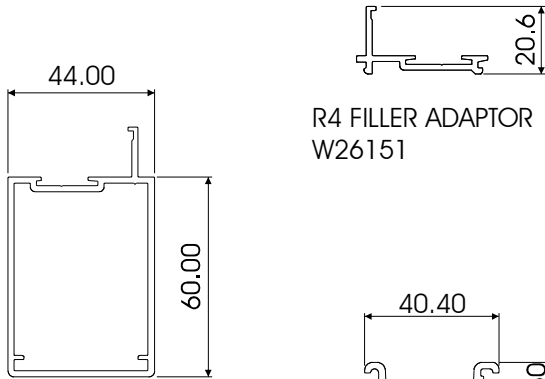

R11 DOOR STILE 60mm
W53099

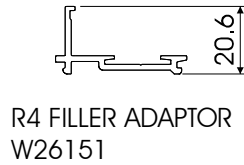

R4 FILLER ADAPTOR
W26151

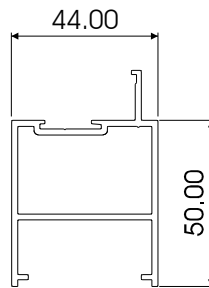

R7 HEAD/SILL
RAIL 50mm
W44087

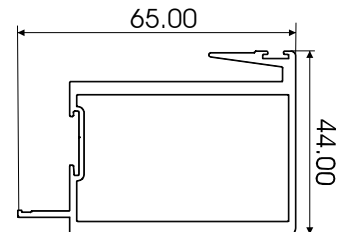

INTERLOCK FIXED 65mm
W56206

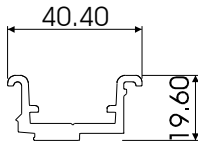

SPIGOT
W26197

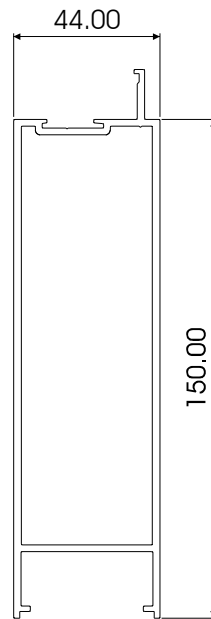

R4 HEAD/SILL RAIL 85mm
W44088

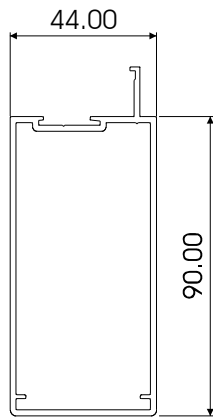

R9 DOOR STILE 90mm
W53406

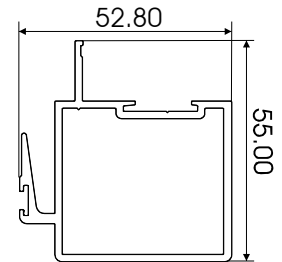

INTERLOCK SLIDE 40mm
W53101

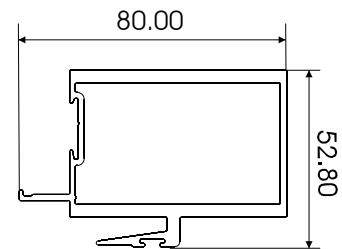

INTERLOCK SLIDE 65mm
W56205

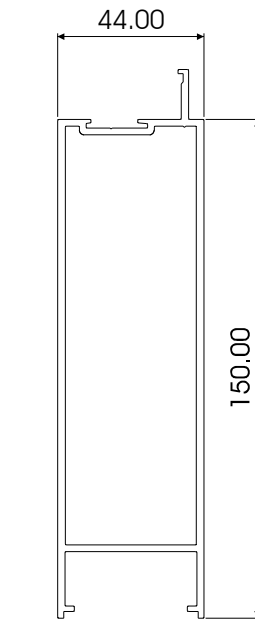

R6 SILL RAIL 150mm
W44094

PALACE HIGH PERFORMANCE SLIDING DOOR PROFILE IDENTIFICATION

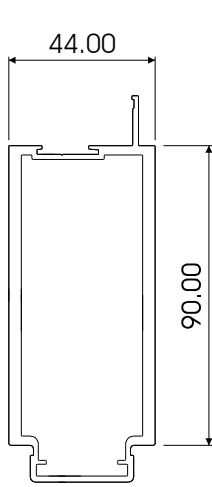

MEETING STILE
90MM
W54966

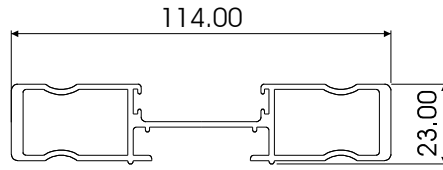

HEAVY DUTY ASTRAGAL
W53223

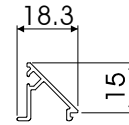

ANGLED
GLAZING BEAD
W14108

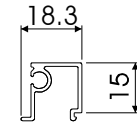

SQUARE
GLAZING BEAD
W14109

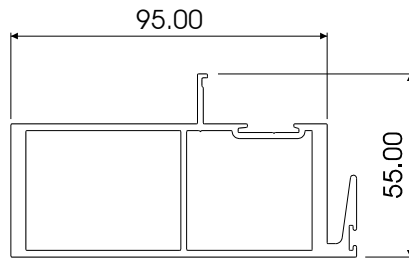

HEAVY DUTY
FIXED INTERLOCKER
W55371

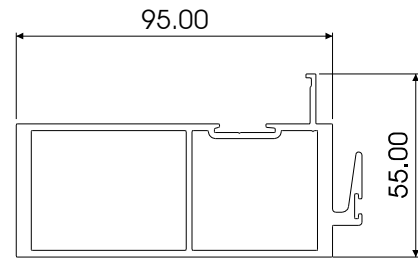

HEAVY DUTY
SLIDING INTERLOCKER
W55370

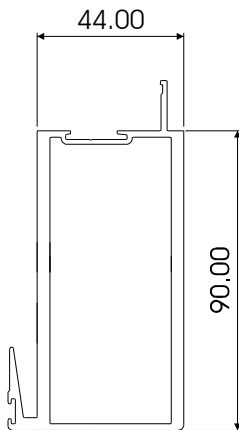

90mm INTER-
LOCKER FS
W54965

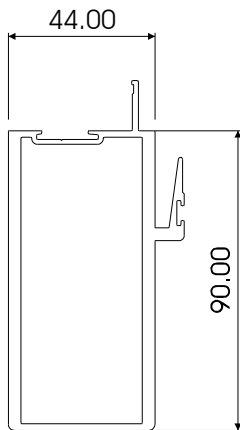

90mm INTER-
LOCKER OS
W54964

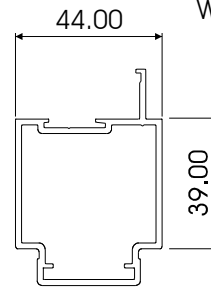

MEETING STILE
W53100

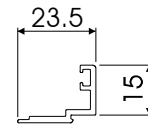

DOUBLE
GLAZING BEAD
W27882

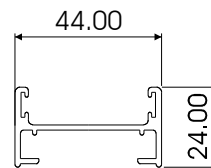

ASTRAGAL
W26399

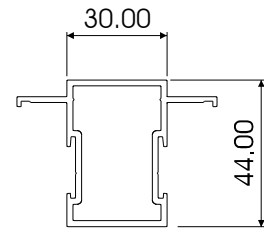

GLAZING BAR
W53033

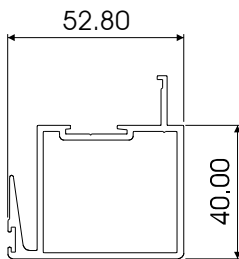

FIXED
INTERLOCKER
W53098

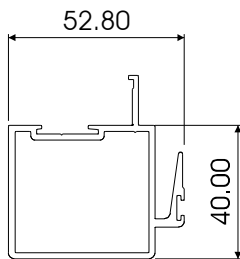

SLIDING
INTERLOCKER
W53101

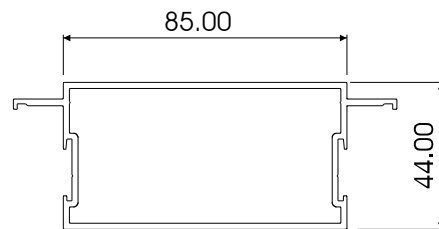

R4 SPECIAL MIDRAIL 85mm
W44089

PALACE HIGH PERFORMANCE SLIDING DOOR HARDWARE IDENTIFICATION

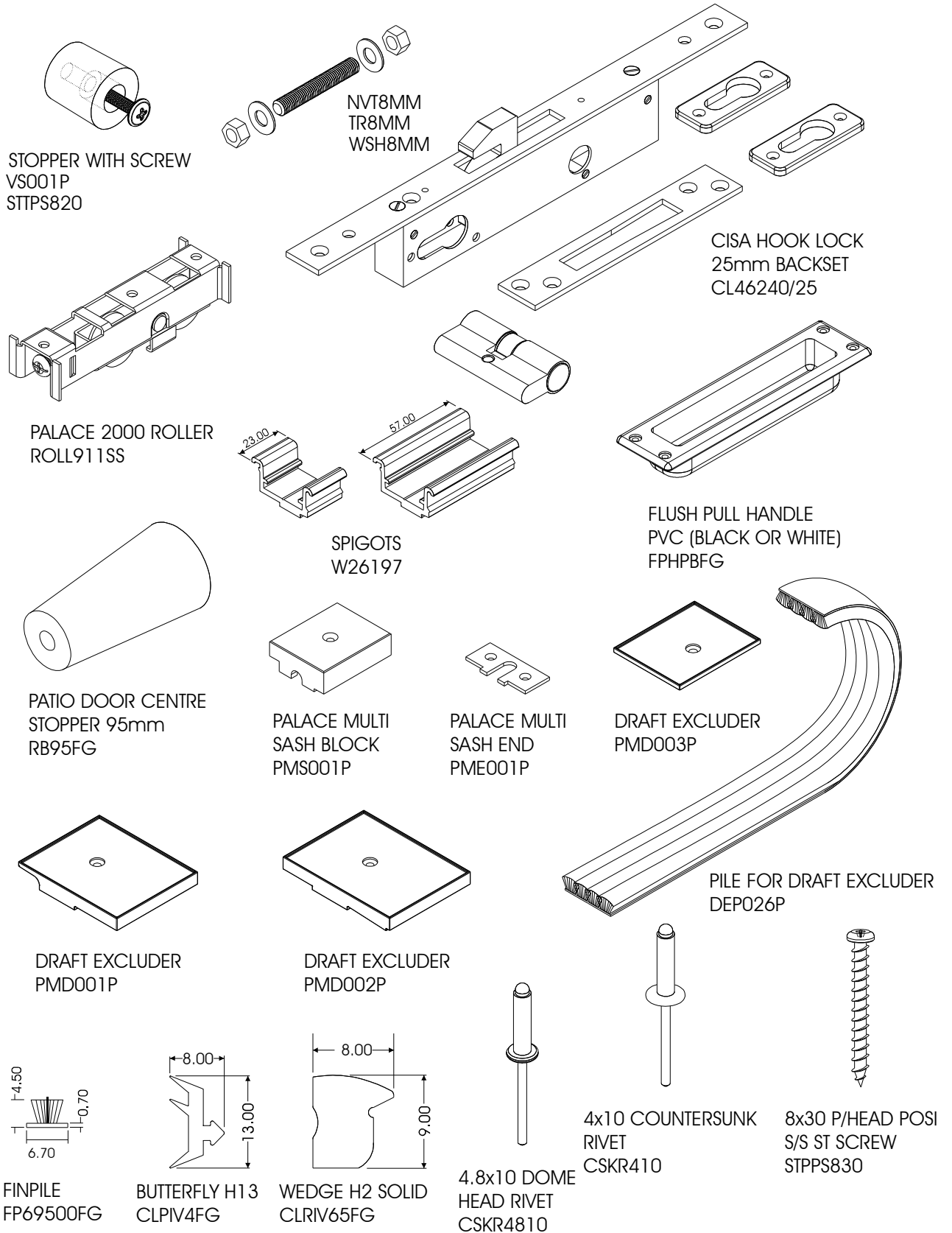

PALACE HIGH PERFORMANCE
SLIDING DOOR
DOUBLE TRACK
CONFIGURATIONS



OX

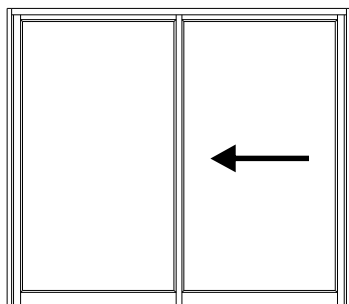

2 PANE MULTI SLIDER

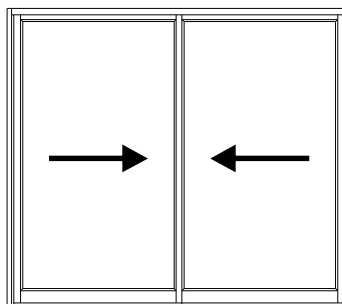

OXXO

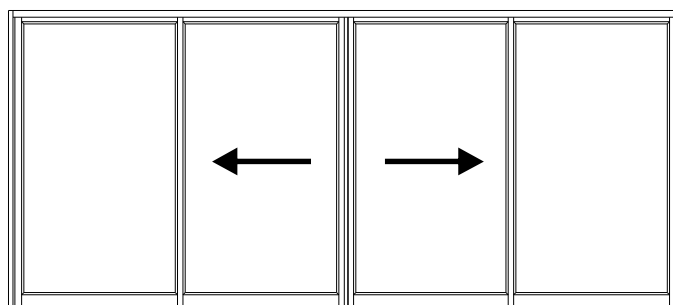

4 PANE MULTI SLIDER

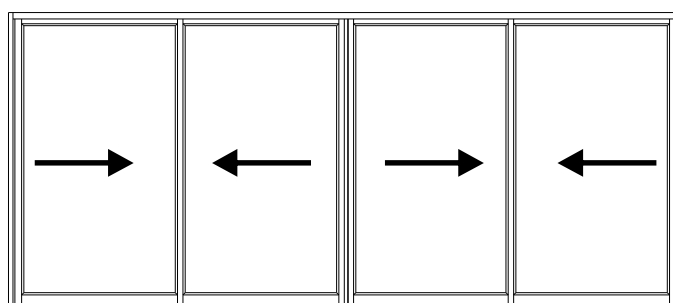

PALACE HIGH PERFORMANCE
SLIDING DOOR
TRIPLE TRACK
CONFIGURATIONS



OXX

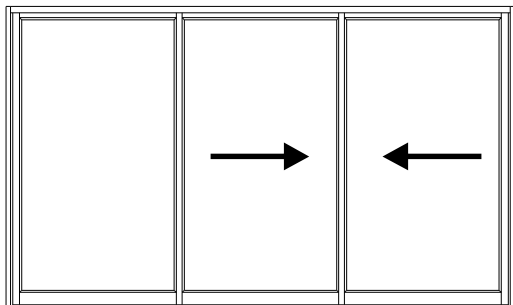

3 PANE MULTI SLIDER

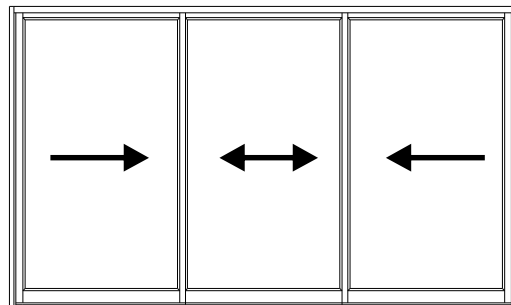

OXXXXO

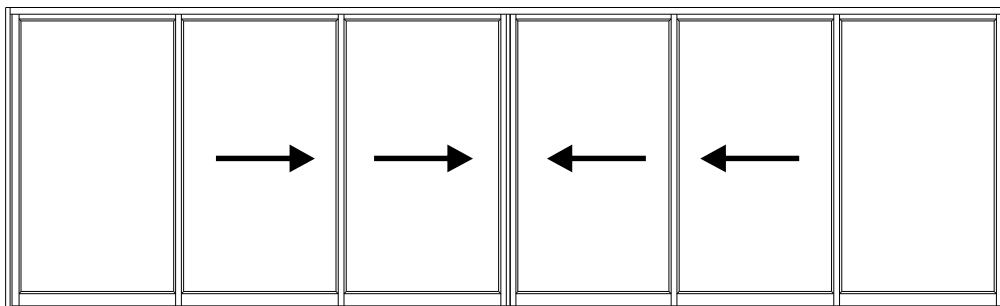

6 PANE MULTI SLIDER

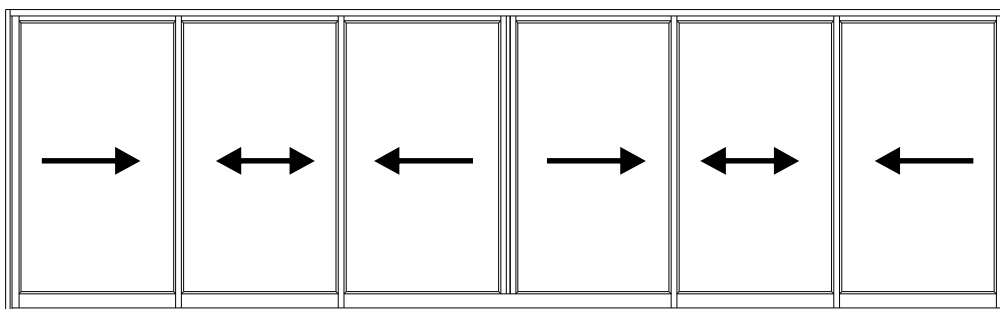

PALACE HIGH PERFORMANCE
SLIDING DOOR
FIXING DETAILS

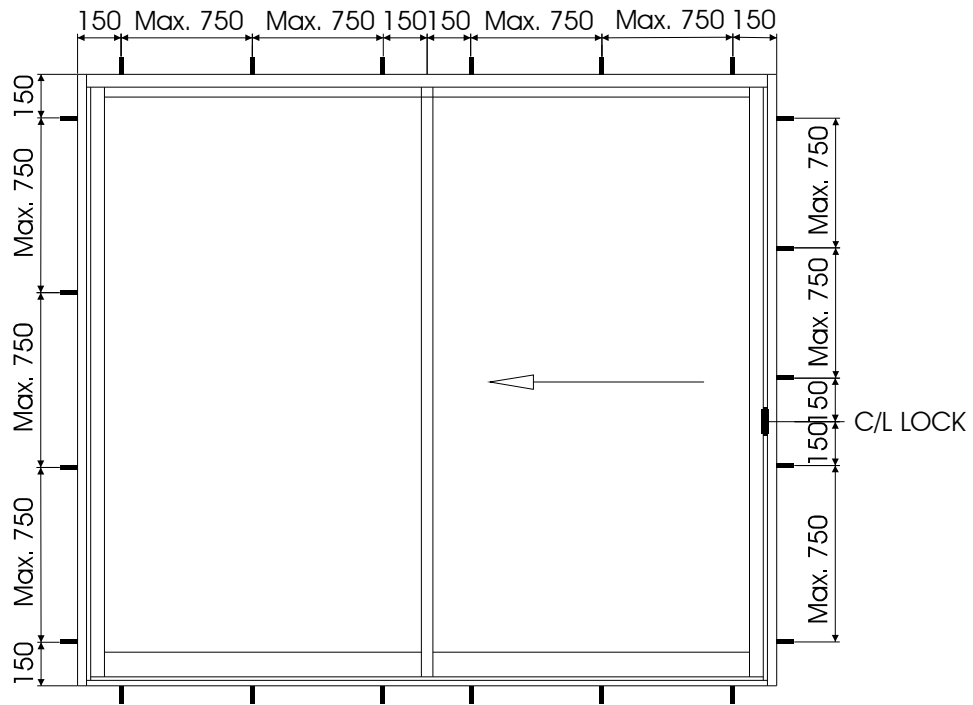

TYPICAL OX SLIDING DOOR &
HORIZONTAL SLIDING WINDOW

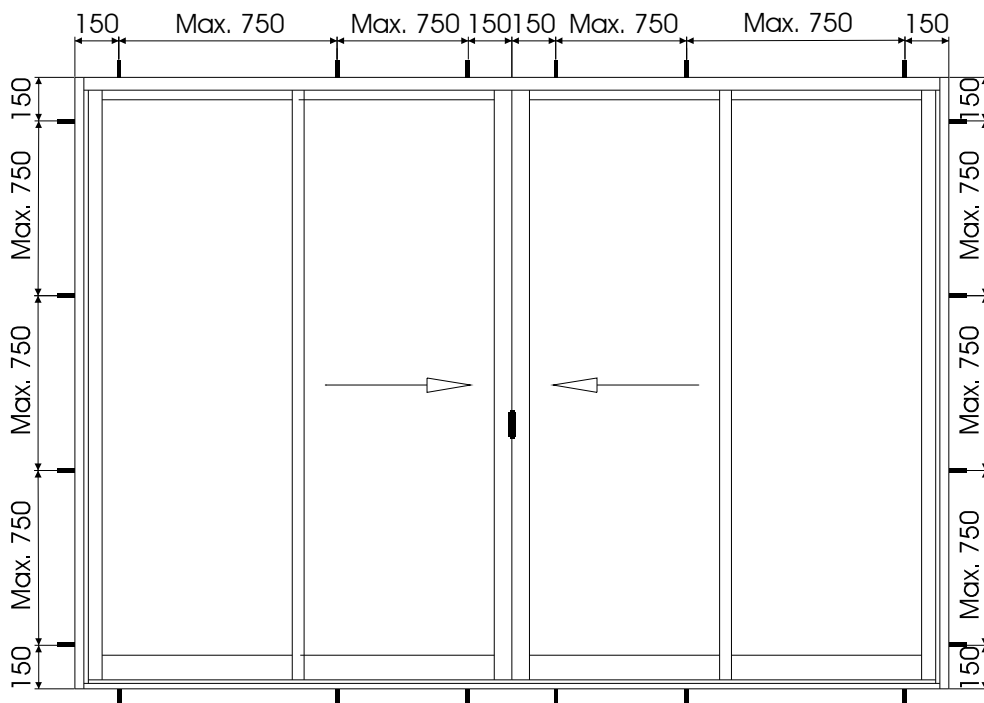

TYPICAL OXXO SLIDING DOOR &
HORIZONTAL SLIDING WINDOW

PALACE HIGH PERFORMANCE
SLIDING DOOR
CROSS SECTIONAL DETAIL
OX CONFIGURATION

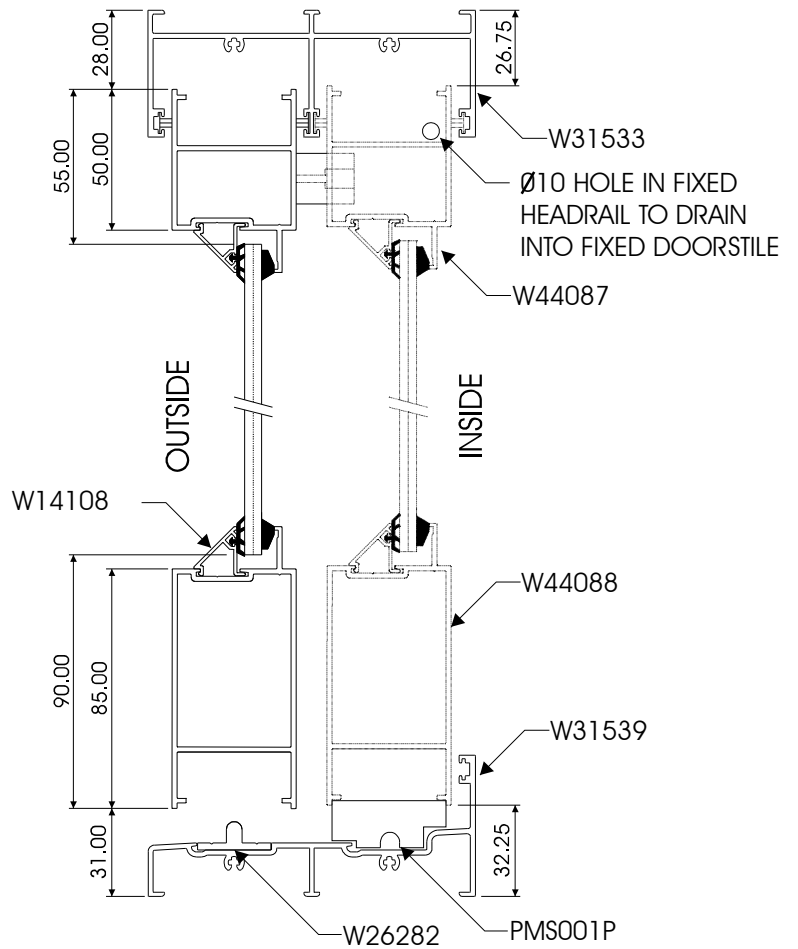
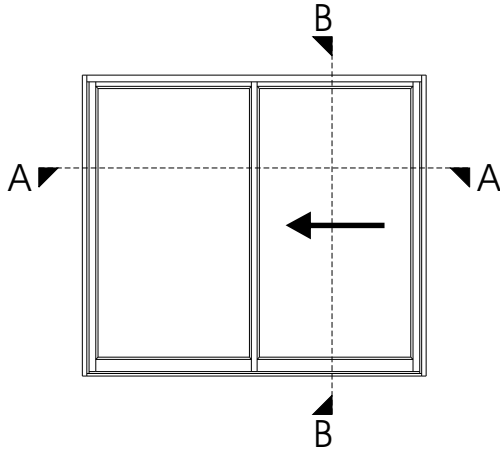

SECTION B - B

Ø10 HOLE IN FIXED
HEADRAIL TO DRAIN
IN FIXED DOORSTILE

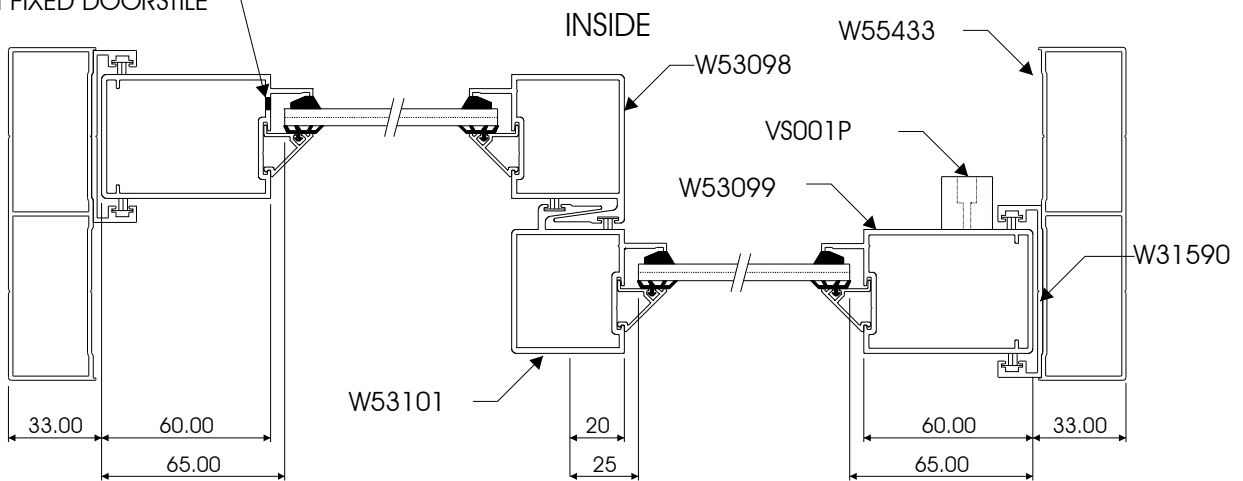

OUTSIDE
SECTION A - A

PALACE HIGH PERFORMANCE
 SLIDING DOOR
 CROSS SECTIONAL DETAIL
 2 PANEL MULTI SLIDER
 CONFIGURATION

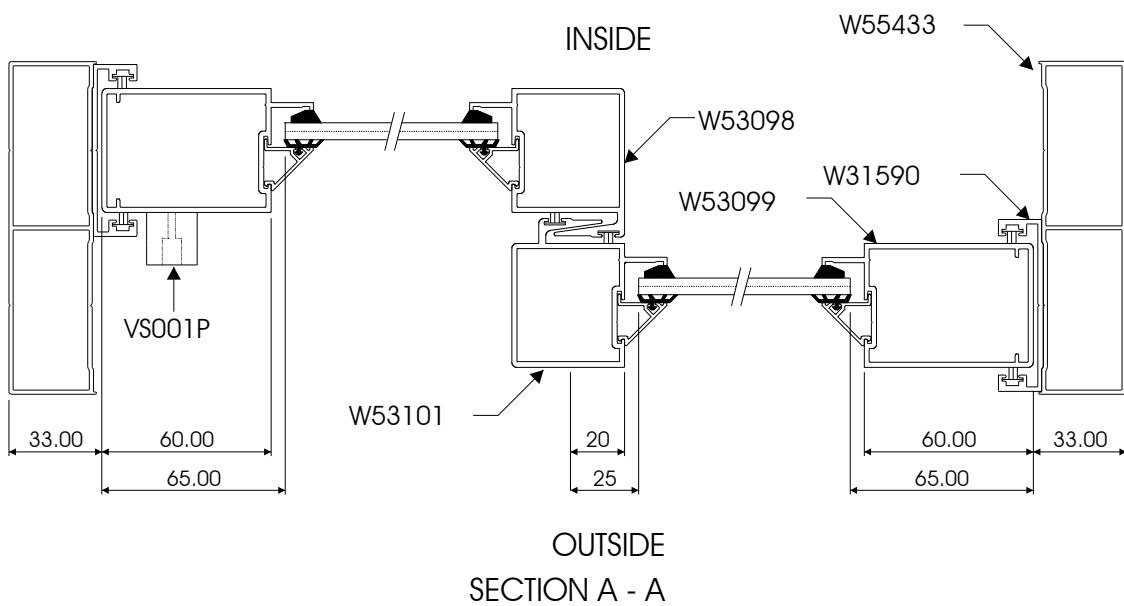
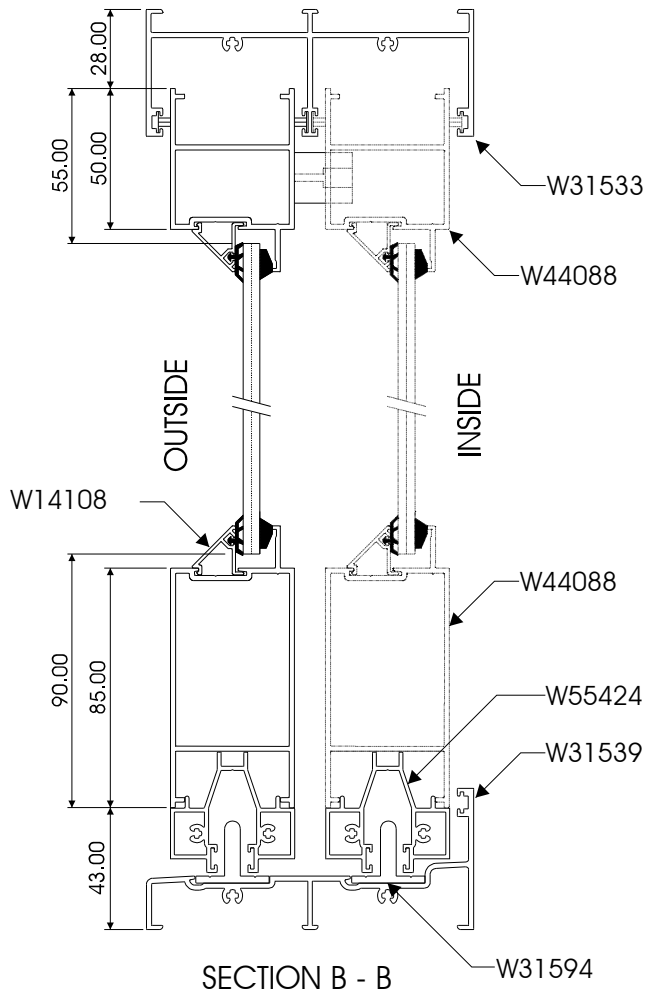
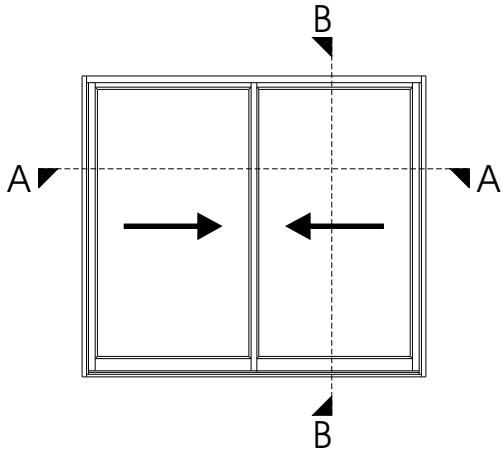

PALACE HIGH PERFORMANCE
SLIDING DOOR
CROSS SECTIONAL DETAIL
OXO CONFIGURATION

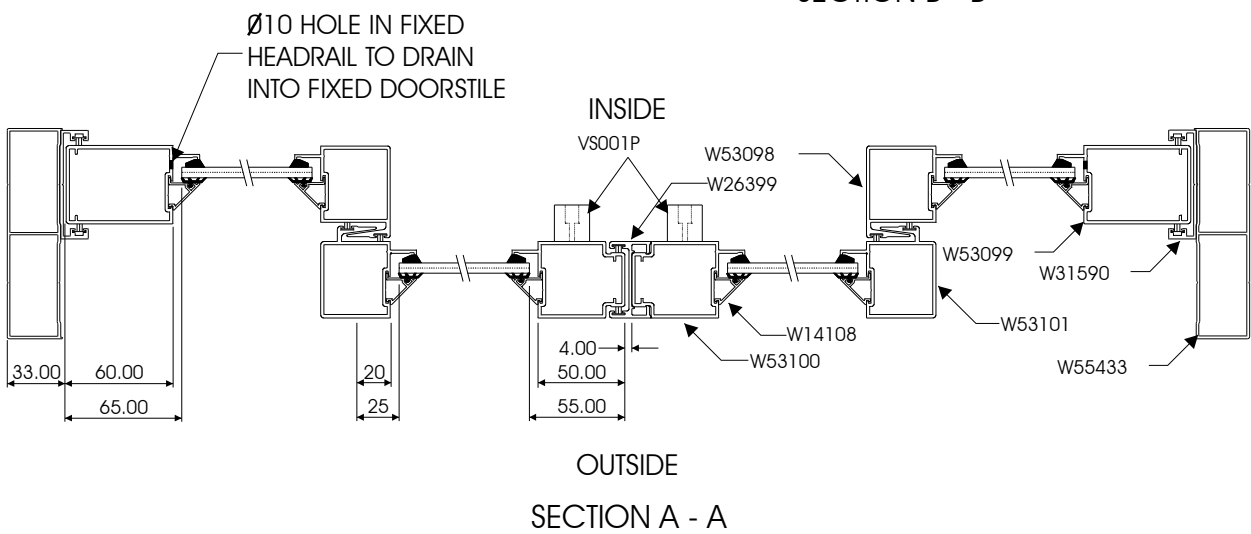
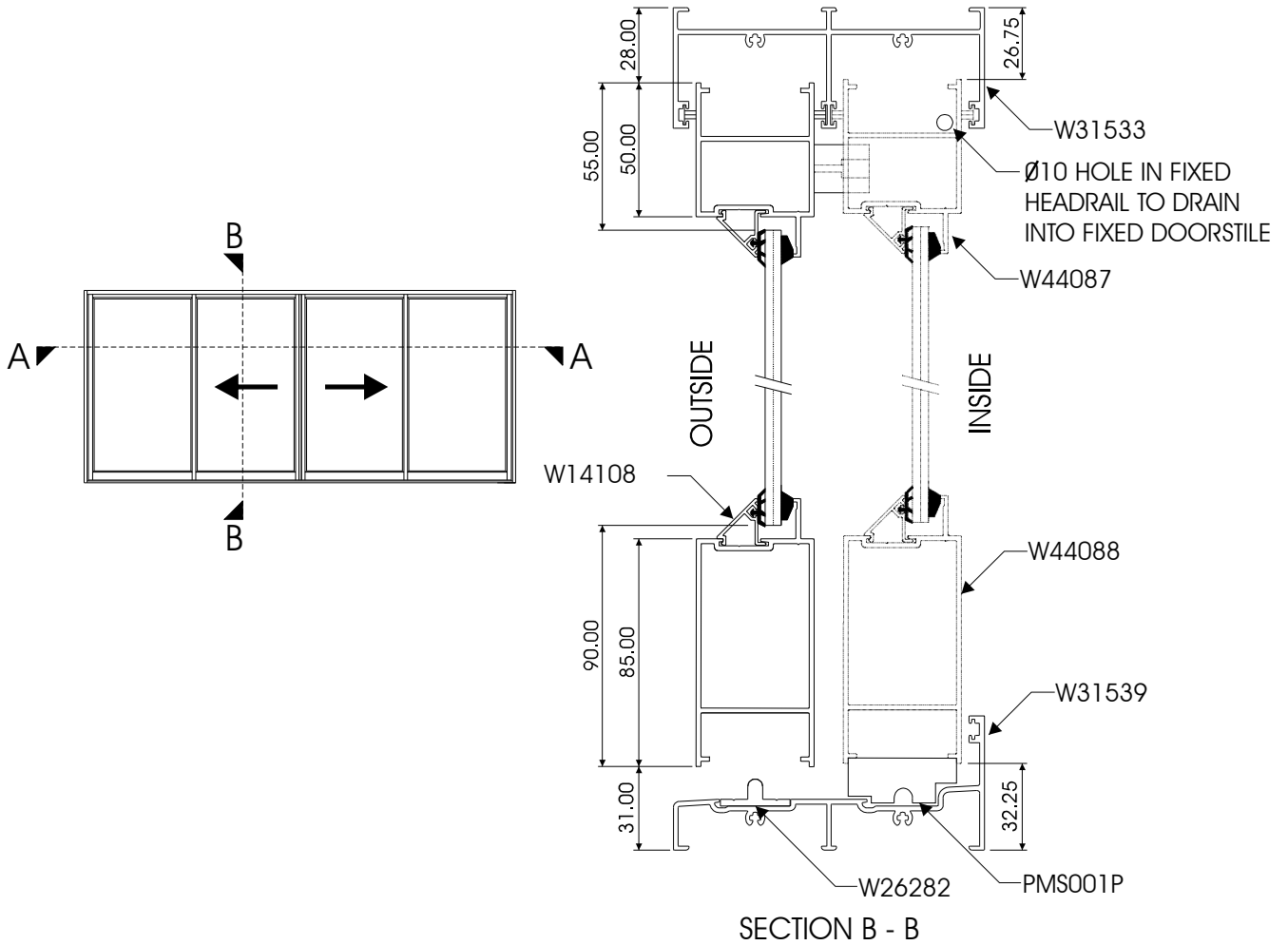

PALACE HIGH PERFORMANCE
 SLIDING DOOR
 CROSS SECTIONAL DETAIL
 4 PANEL MULTI SLIDER
 CONFIGURATION

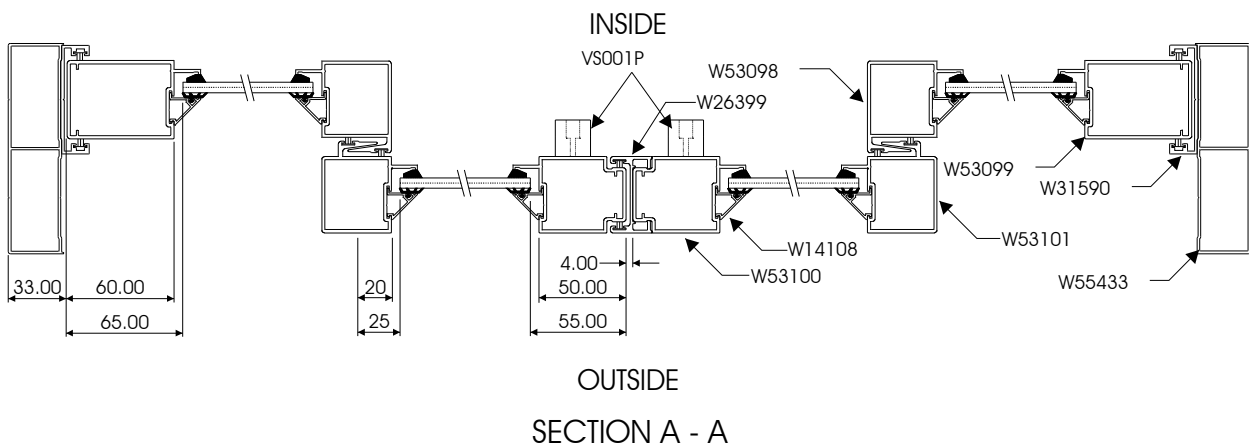
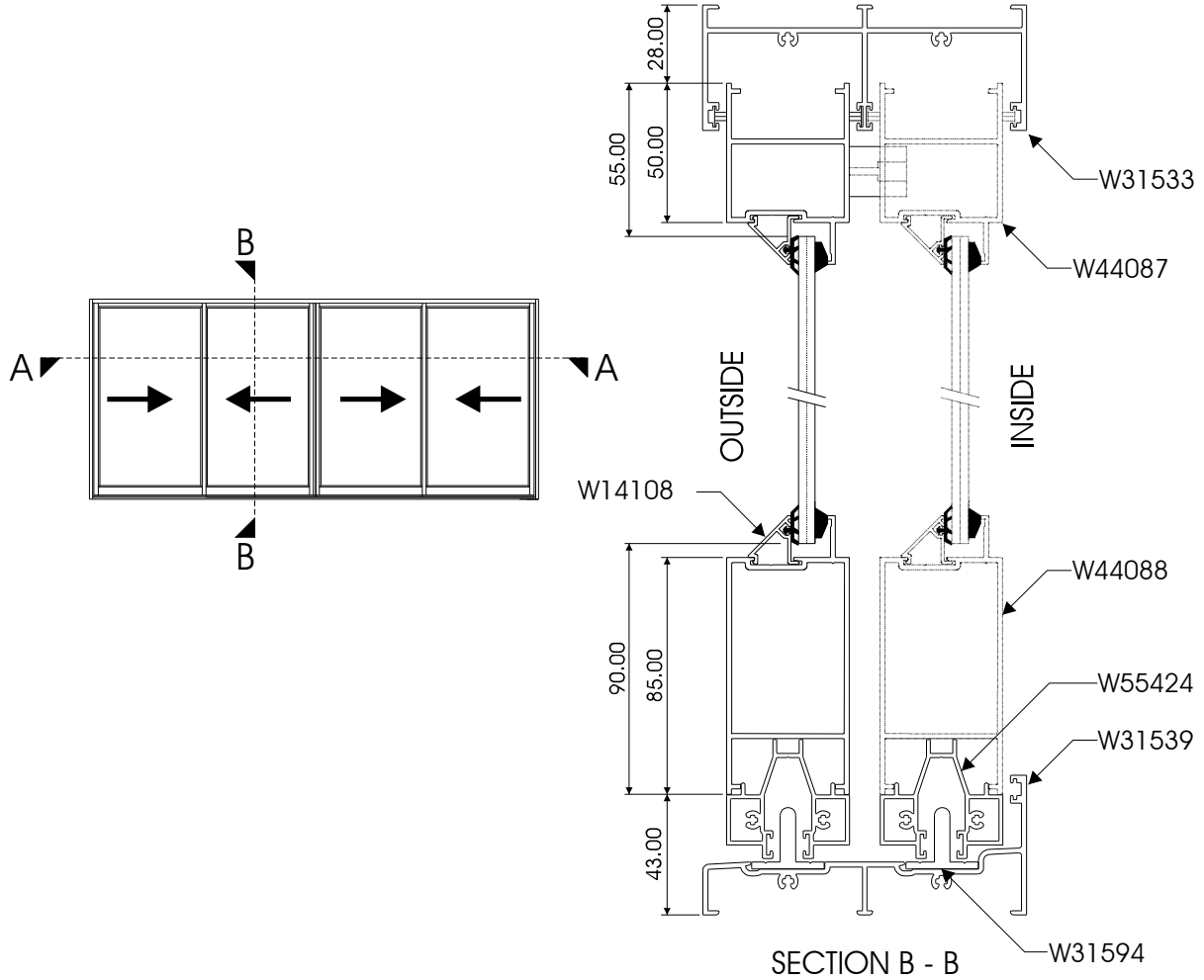

PALACE HIGH PERFORMANCE
SLIDING DOOR
CROSS SECTIONAL DETAIL
OXX CONFIGURATION

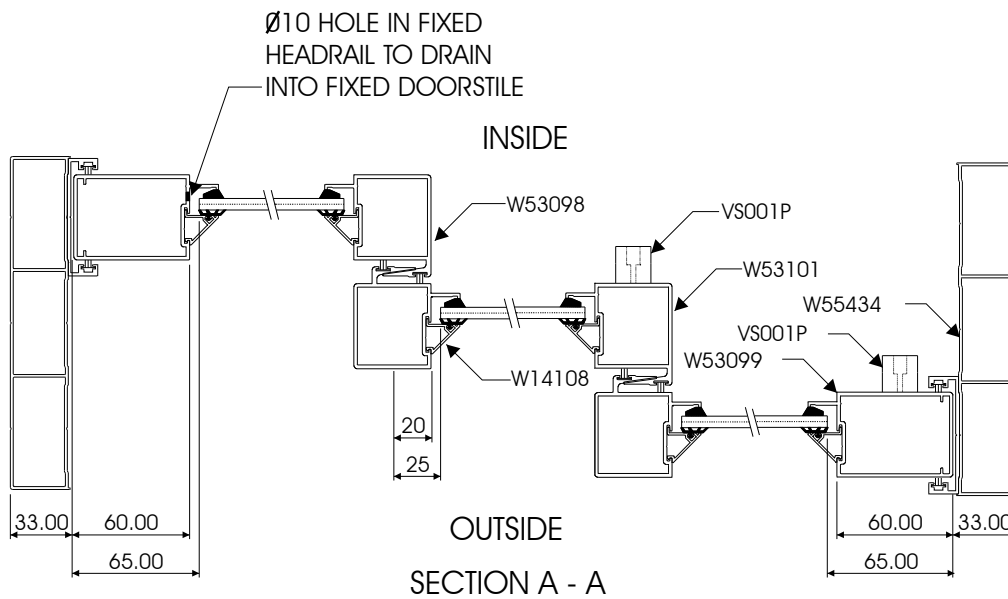
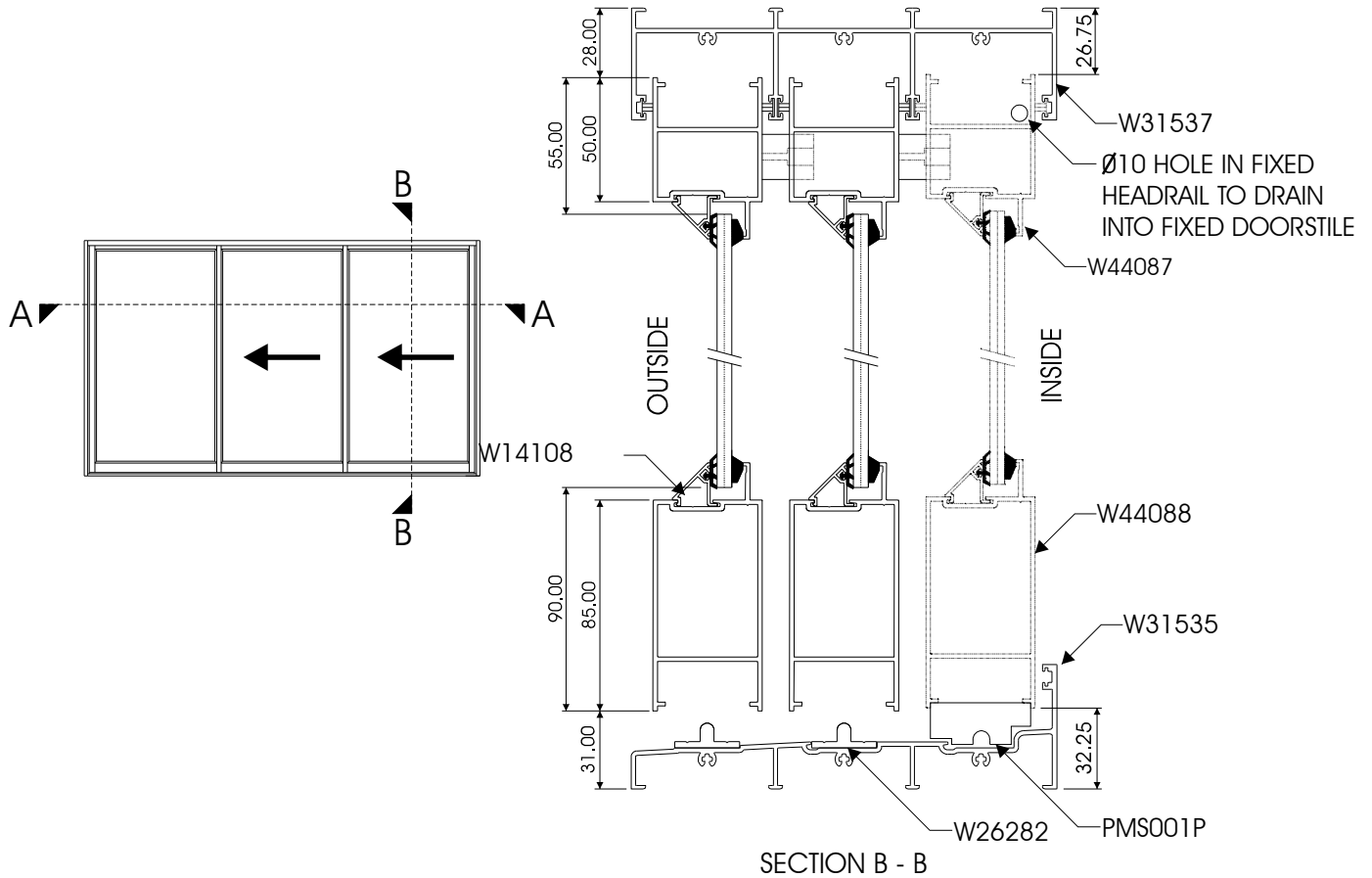

PALACE HIGH PERFORMANCE
 SLIDING DOOR
 CROSS SECTIONAL DETAIL
 3 PANEL MULTI SLIDER
 CONFIGURATION

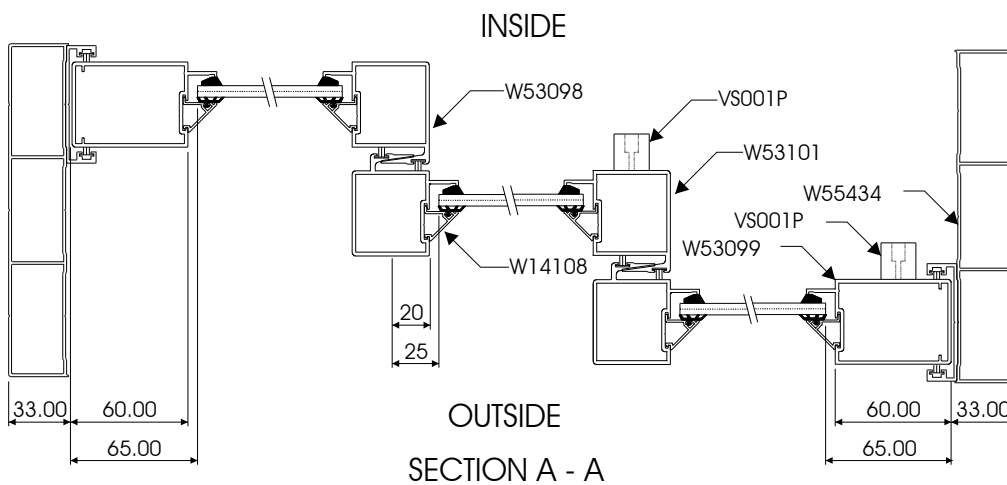
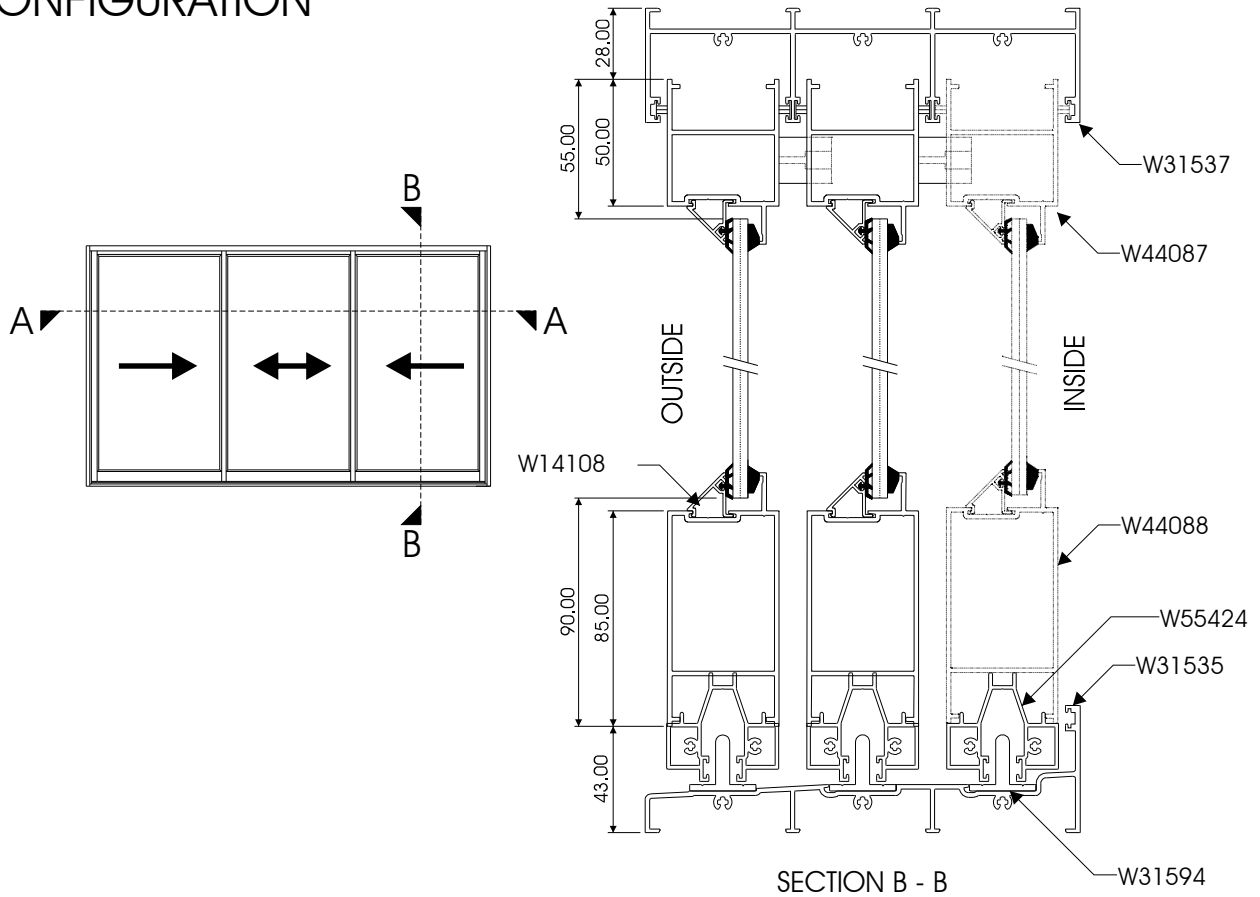

PALACE HIGH PERFORMANCE
 SLIDING DOOR
 CROSS SECTIONAL DETAIL
 OXXXXO CONFIGURATION

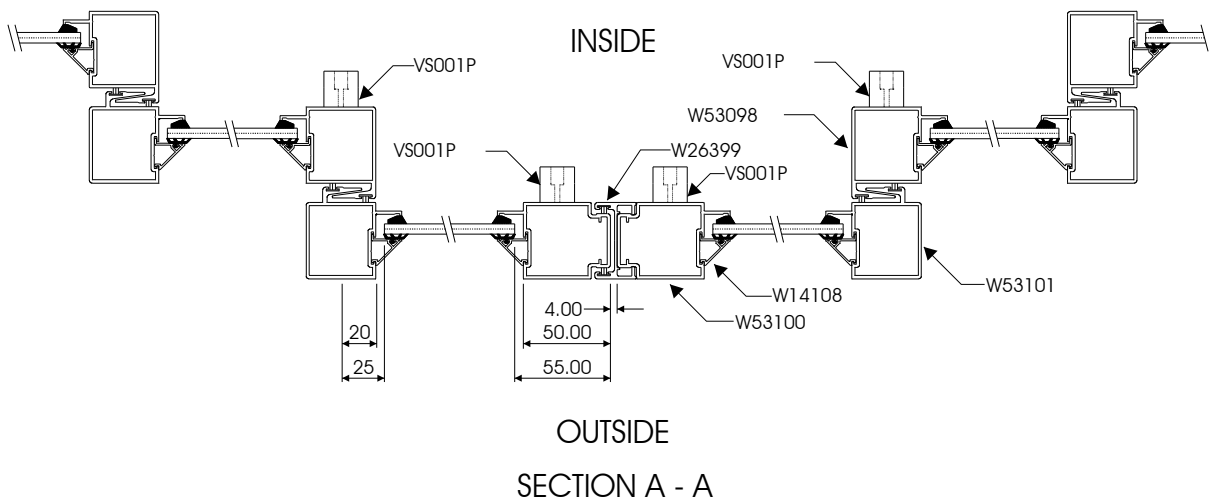
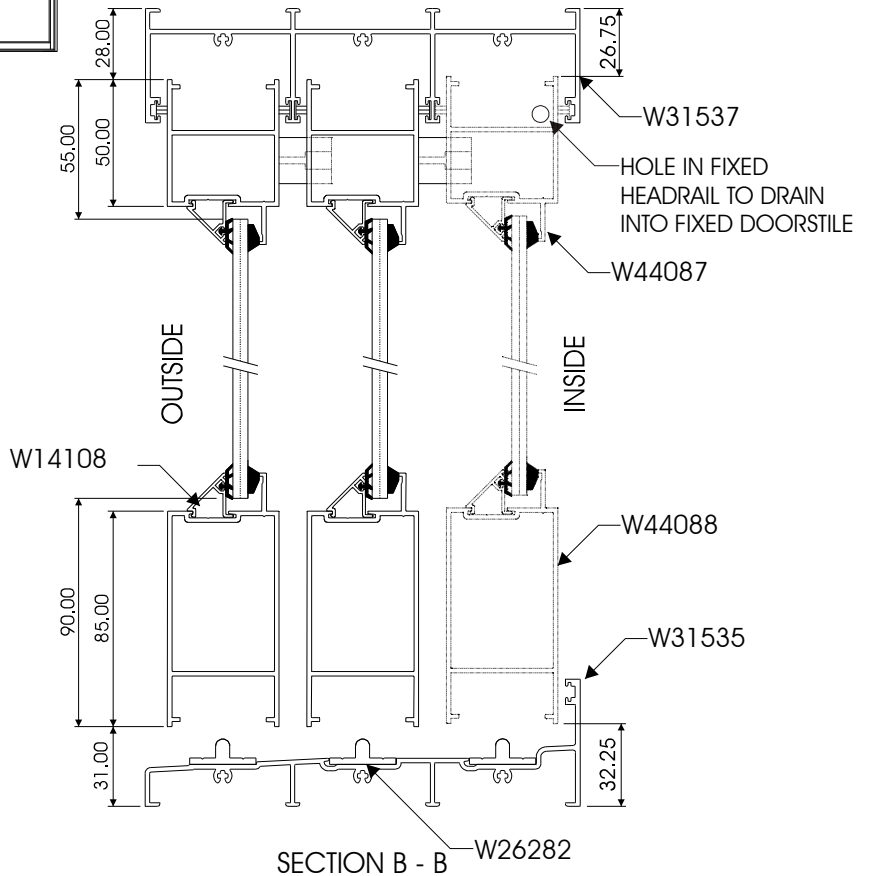
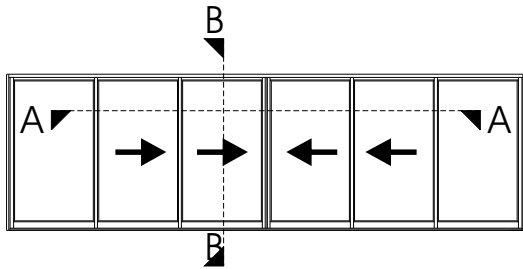

PALACE HIGH PERFORMANCE
 SLIDING DOOR
 CROSS SECTIONAL DETAIL
 6 PANEL MULTI SLIDER
 CONFIGURATION

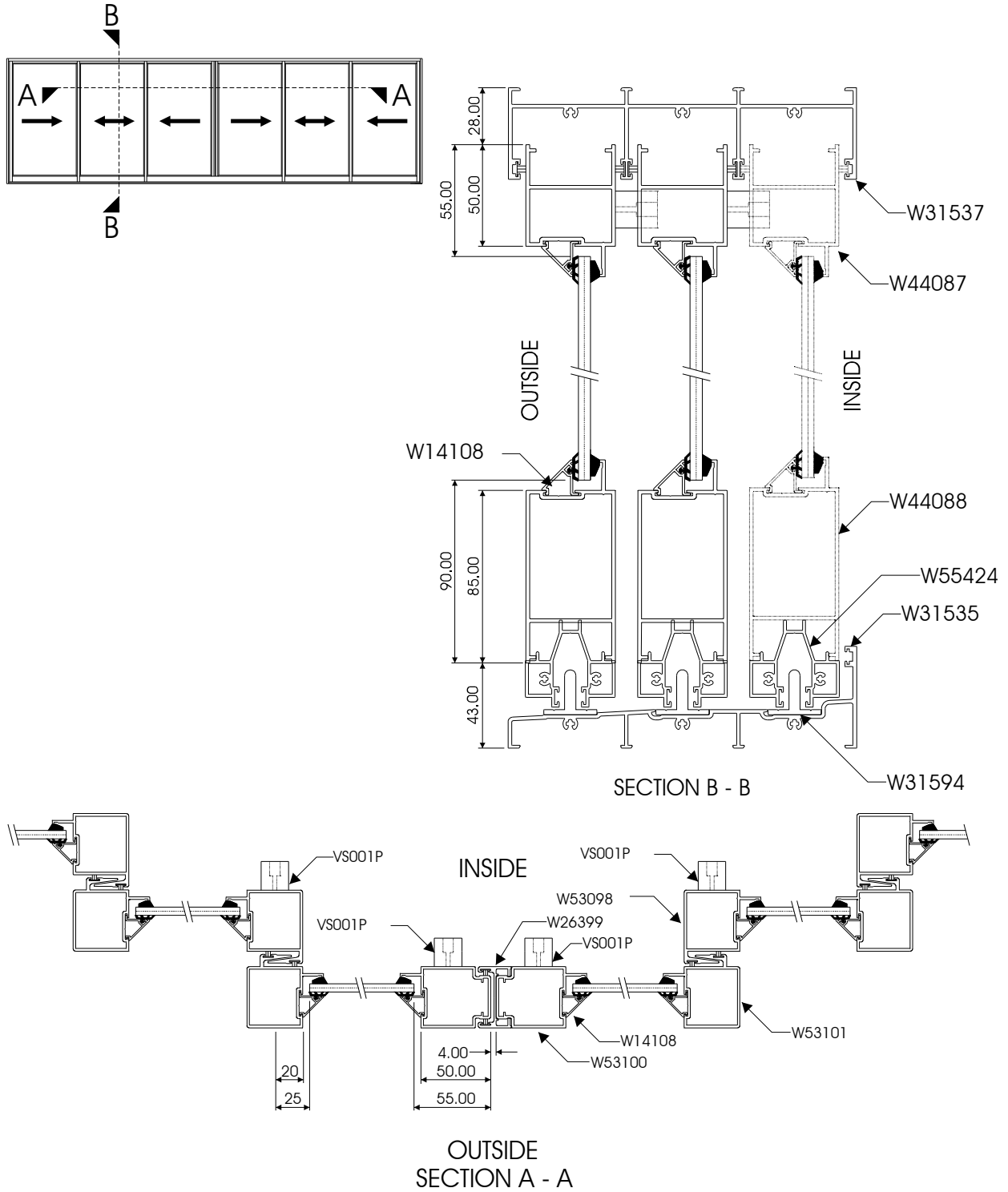

PALACE HIGH PERFORMANCE
 SLIDING DOOR
 OUTER FRAME COMPONENT
 ASSEMBLY DETAIL
 DOUBLE TRACK

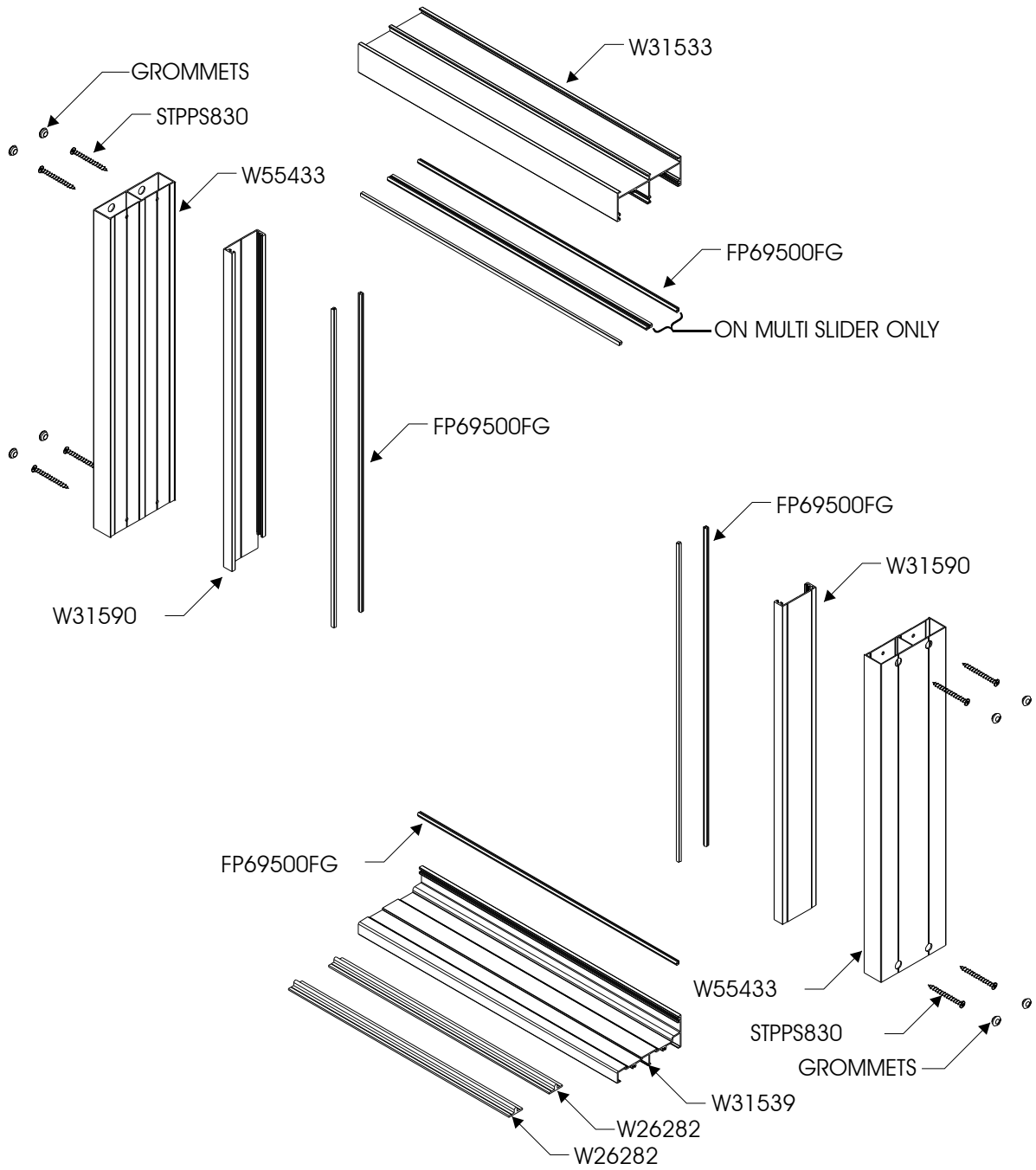

PALACE HIGH PERFORMANCE
 SLIDING DOOR
 OUTER FRAME COMPONENT
 ASSEMBLY DETAIL
 TRIPLE TRACK

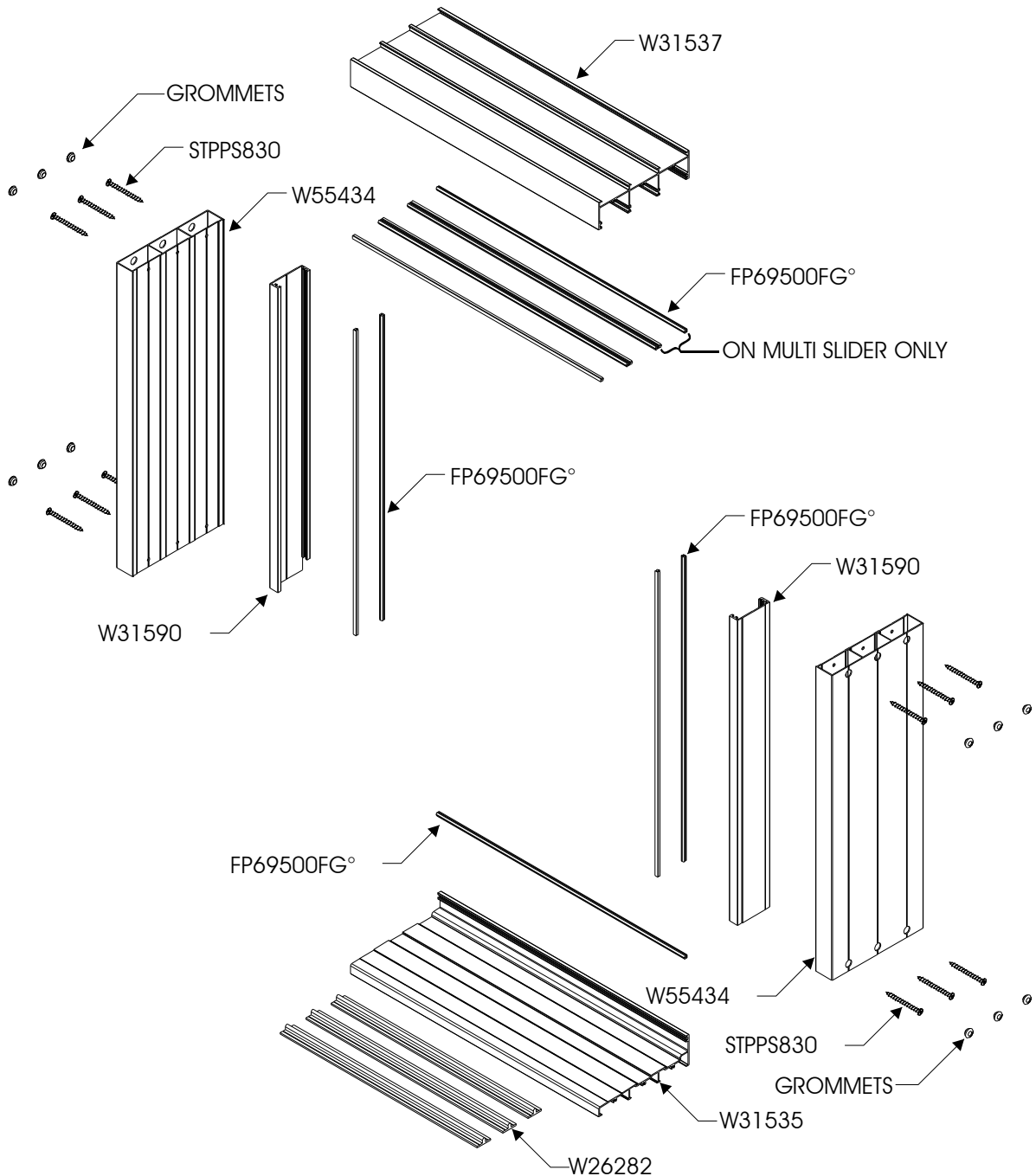

○ FINPILE ONLY ON MULTI SLIDER XX, XXX OR XXXXXX
 NO FINPILE ON OX, OXXO, OXX AND OXXXXO

PALACE HIGH PERFORMANCE
 SLIDING DOOR
 INSERT COMPONENT
 ASSEMBLY DETAIL
 SLIDING/FIXED

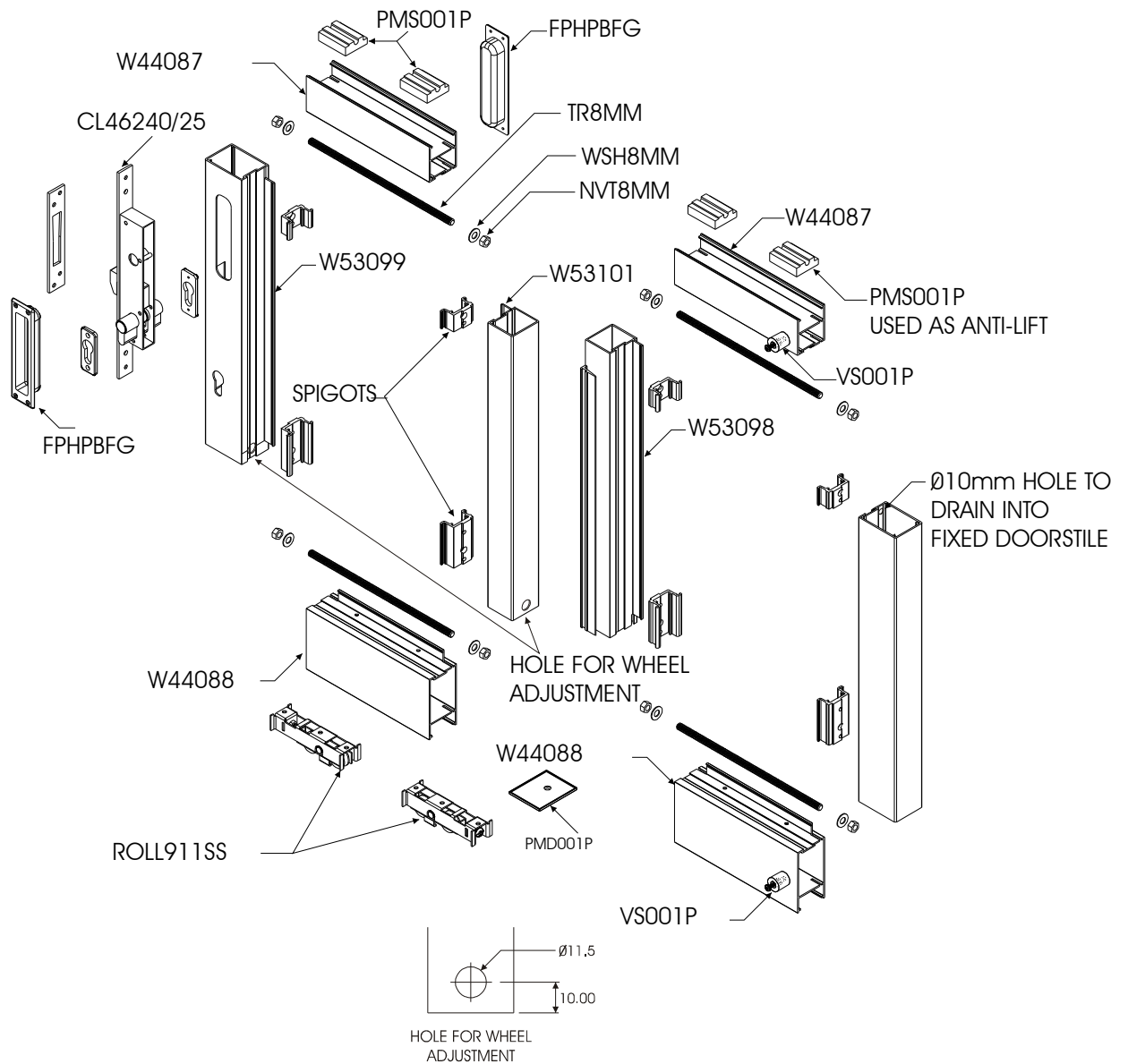

PALACE HIGH PERFORMANCE
 SLIDING DOOR
 INSERT COMPONENT
 ASSEMBLY DETAIL
 SLIDING/SLIDING

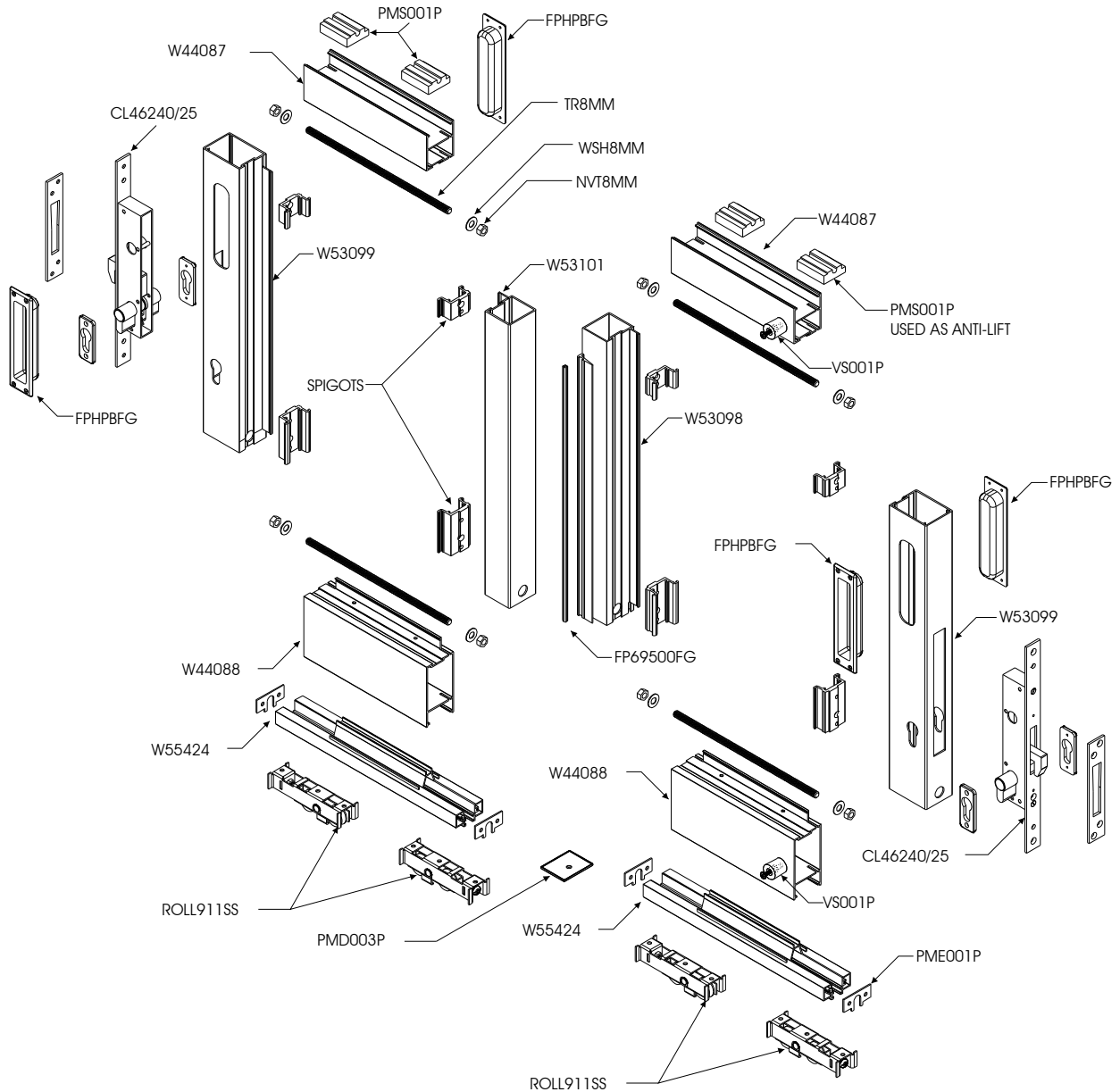

PALACE HIGH PERFORMANCE
 SLIDING DOOR
 CUTTING DETAIL
 W55424

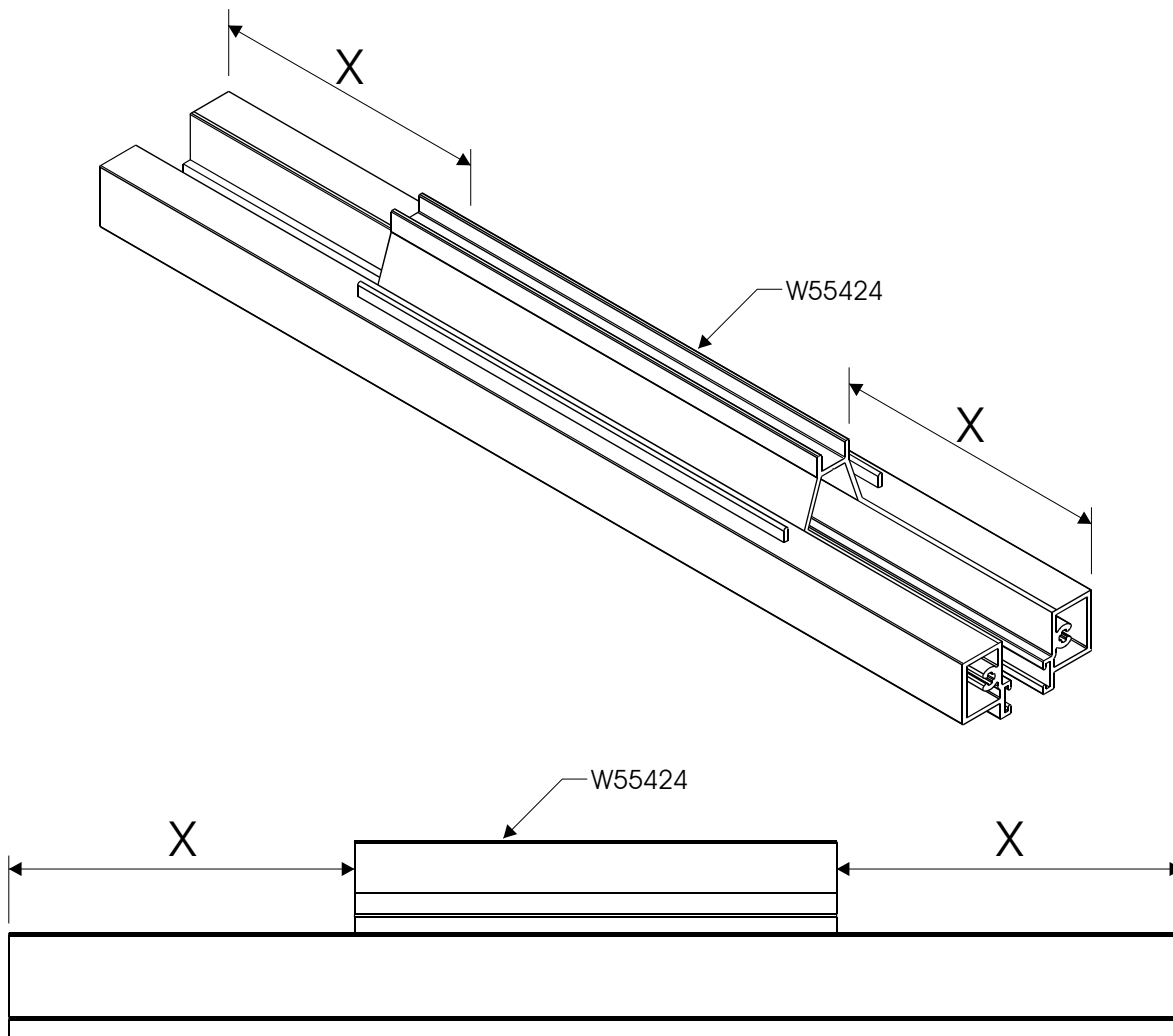

	X
45 STILE / INTERLOCK	180mm
60 STILE / INTERLOCK	195mm
90 STILE / INTERLOCK	225mm

PALACE HIGH PERFORMANCE
SLIDING DOOR
DRAUGHT EXCLUDERS
2 & 4 PANE SLIDERS



Draught Excluder(s) to be used:

1. Use PMD001P underneath the interlockers.
2. The pile for Draught Excluder (DEP026P) must be used with the above mentioned Draught Excluder.

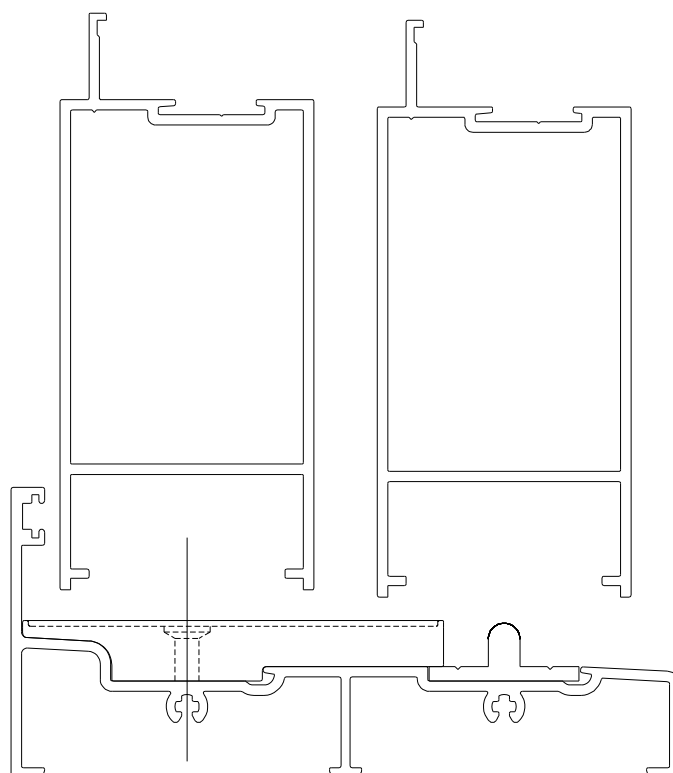

VERTICAL SECTION
Two & Four Pane Sliders

PALACE HIGH PERFORMANCE
SLIDING DOOR
SASH BLOCK
2 & 4 PANE SLIDERS



Sash Block:

1. Use Palace Multi Sash Block (PMS001P) under the fixed panels to lift it to the correct height from the sill.
2. The Sash Block can also be screwed to the Head Rail as an anti lift device.

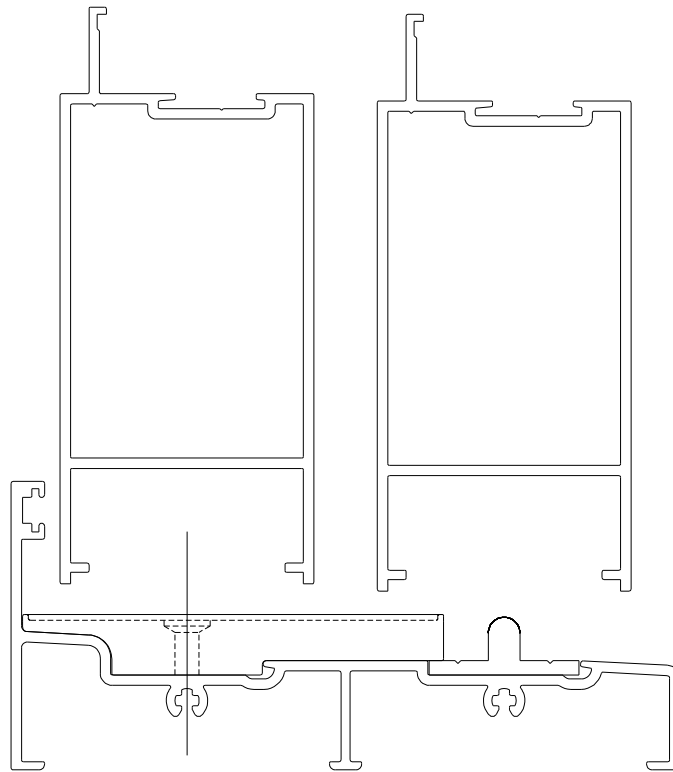

VERTICAL SECTION
Two & Four Pane Sliders

PALACE HIGH PERFORMANCE
SLIDING DOOR
DRAUGHT EXCLUDERS
3 & 6 PANE MULTI SLIDERS



Draught Excluder(s) to be used:

1. Use PMD003P underneath the interlockers.
2. The pile for Draught Excluder (DEP026P) must be used with the above mentioned Draught Excluder.

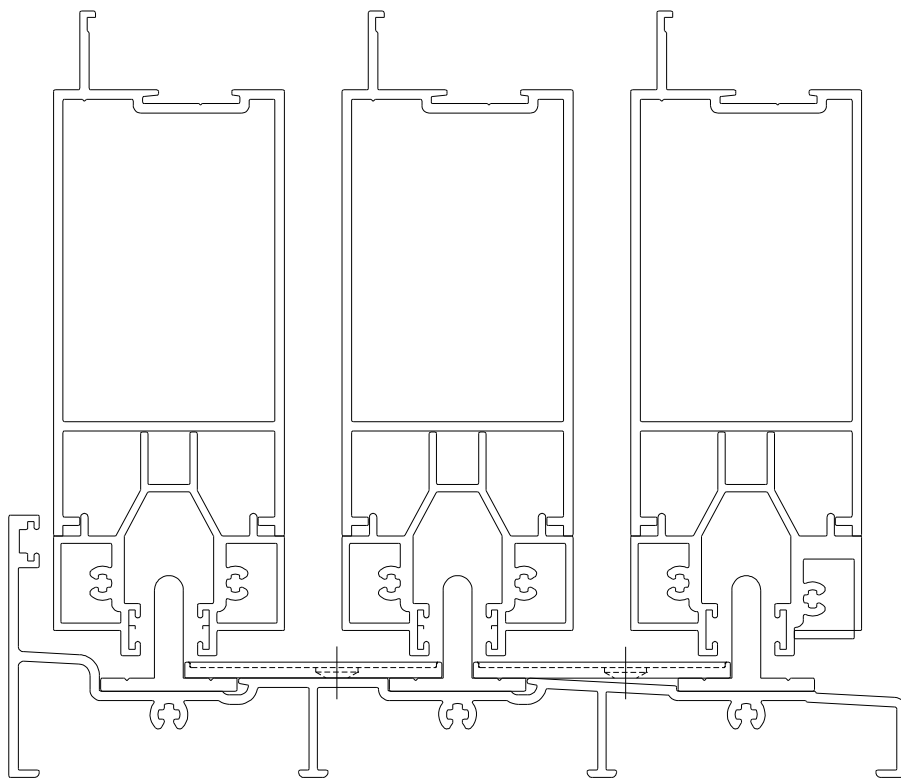

VERTICAL SECTION
Three & Six Panel Pane Multi Sliders

PALACE HIGH PERFORMANCE
SLIDING DOOR
DRAUGHT EXCLUDERS
3 & 6 PANE MULTI SLIDERS



Draught Excluder(s) to be used:

1. Use PMD001P underneath the interlockers.
2. The pile for Draught Excluder (DEP026P) must be used with the above mentioned Draught Excluder.

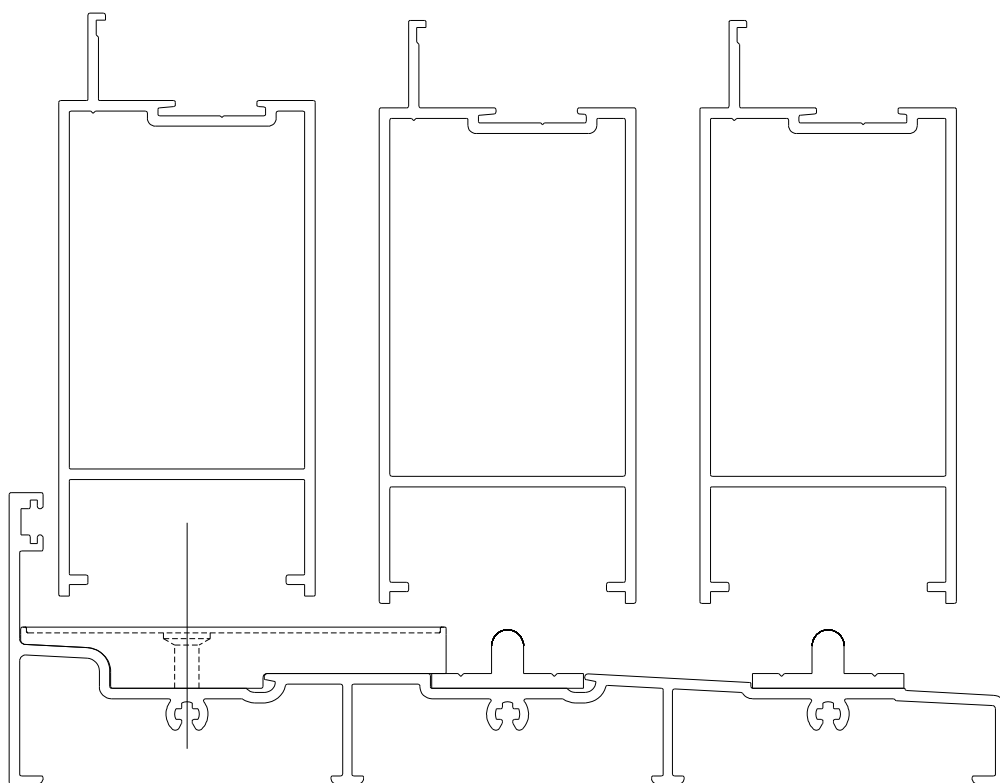

VERTICAL SECTION
Three & Six Panel Pane Multi Sliders

PALACE HIGH PERFORMANCE
SLIDING DOOR
DRAUGHT EXCLUDERS
3 & 6 PANE MULTI SLIDERS



Draught Excluder(s) to be used:

1. Use PMD002P underneath the interlockers.
2. The pile for Draught Excluder (DEP026P) must be used with the above mentioned Draught Excluder.

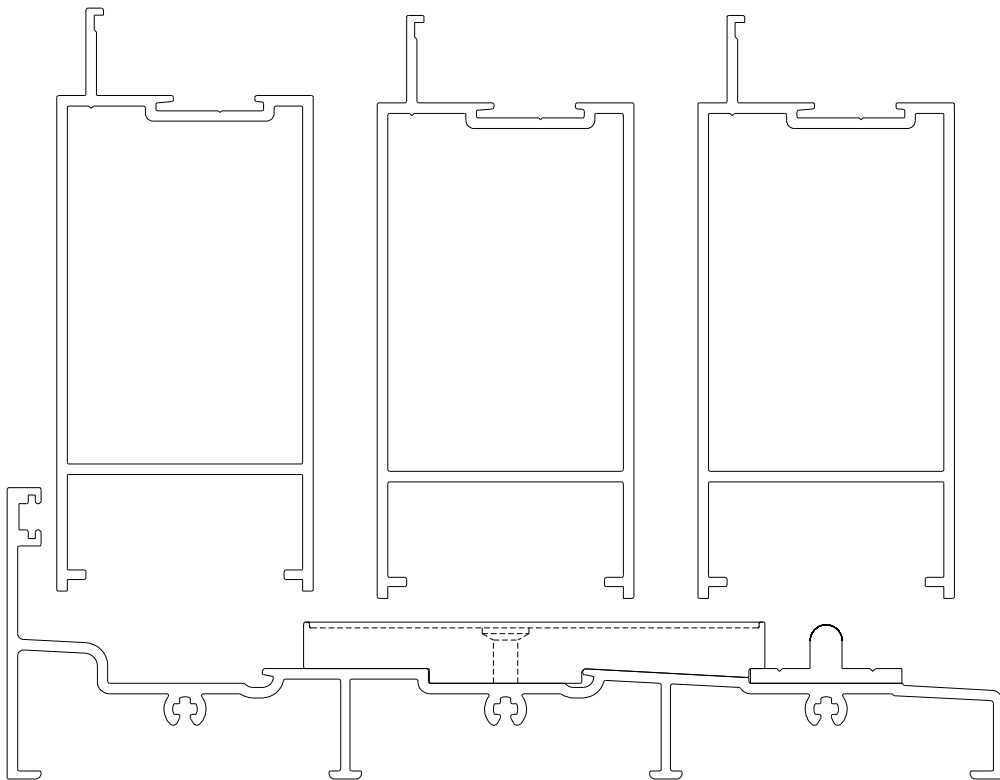

VERTICAL SECTION
Three & Six Panel Pane Multi Sliders

PALACE HIGH PERFORMANCE
SLIDING DOOR
DETAIL SHOWING ROLL911SS
AGAINST DOOR JAMB LIP

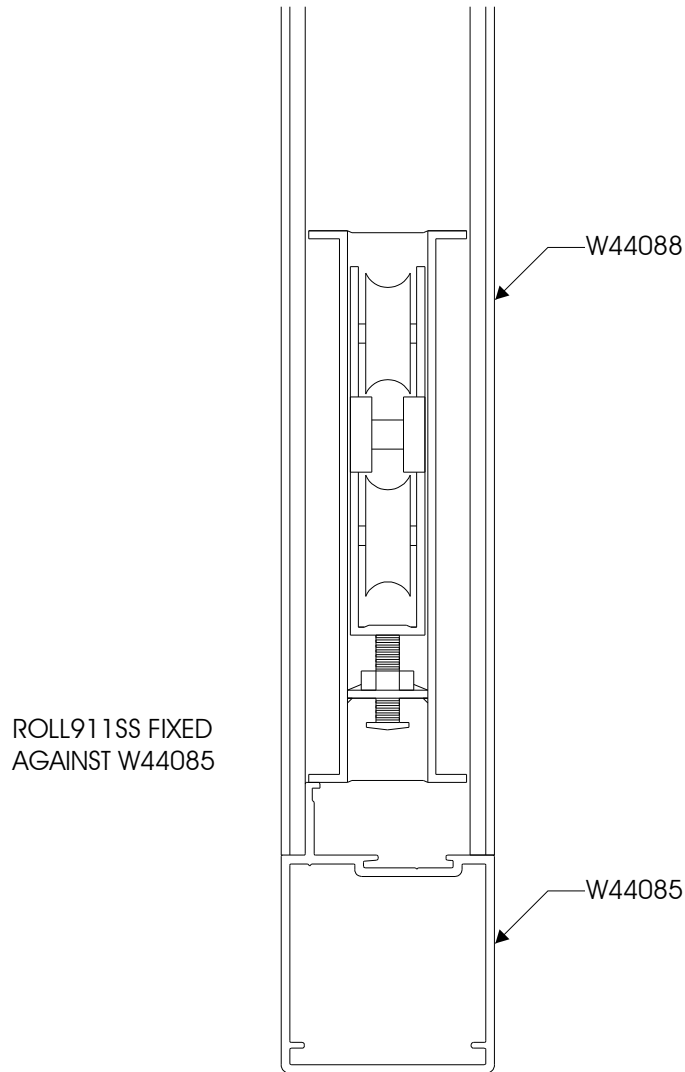

PALACE HIGH PERFORMANCE
SLIDING DOOR
DOUBLE SILL
FLOOR LEVEL DETAIL

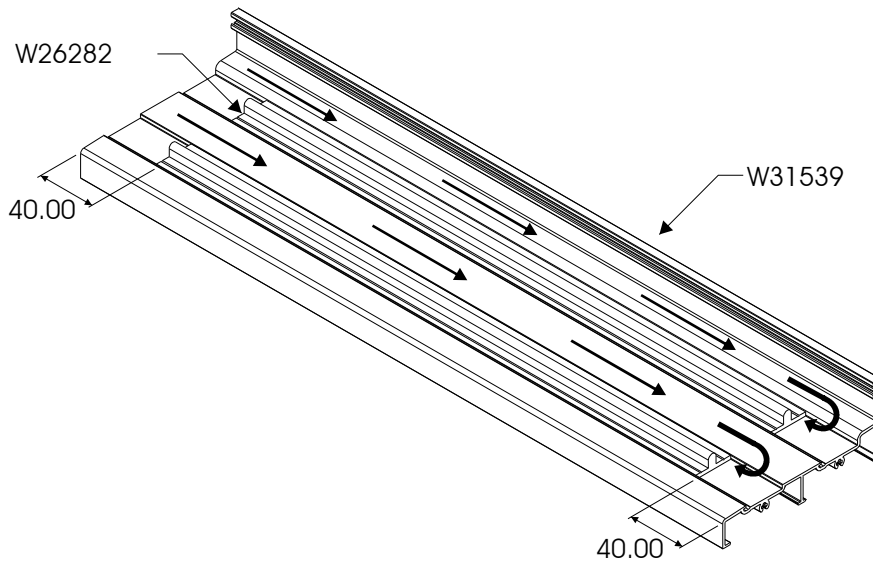

WATER CHANNELS
AROUND TRACK

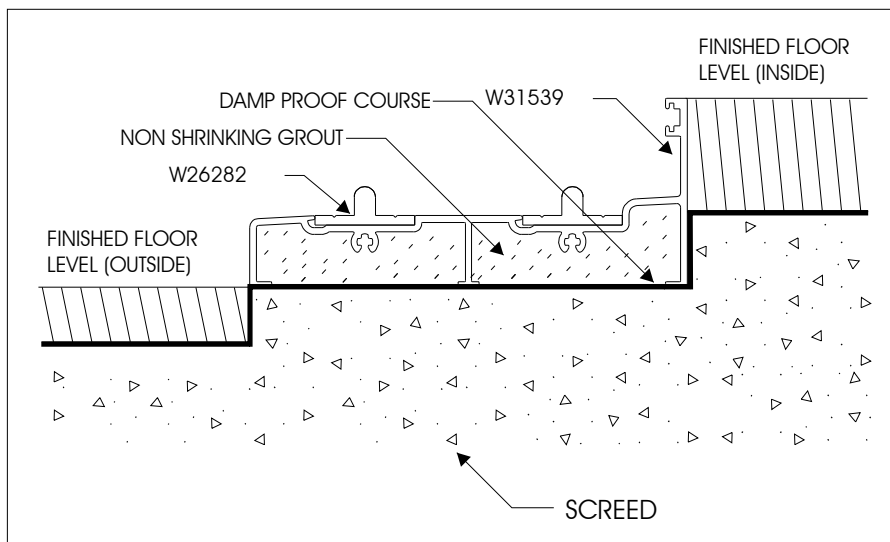

PALACE HIGH PERFORMANCE
SLIDING DOOR
TRIPLE SILL
FLOOR LEVEL DETAIL

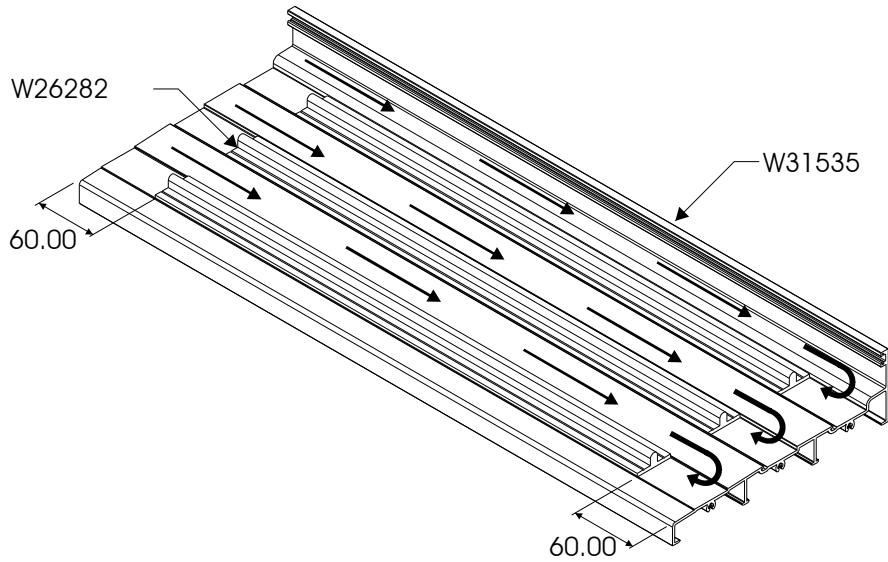

WATER CHANNELS
AROUND TRACK

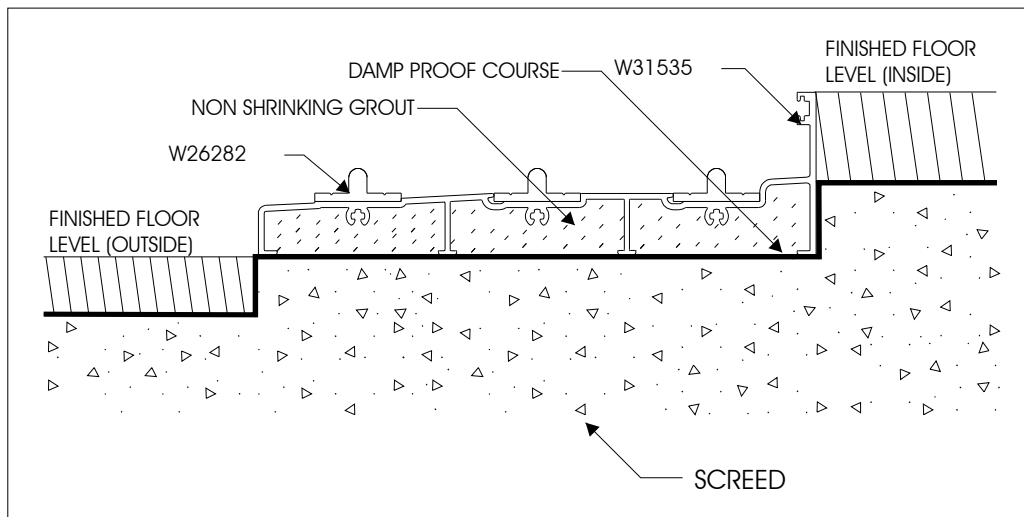

PALACE HIGH PERFORMANCE
 SLIDING DOOR
 DOUBLE JAMB
 MACHINING DETAIL

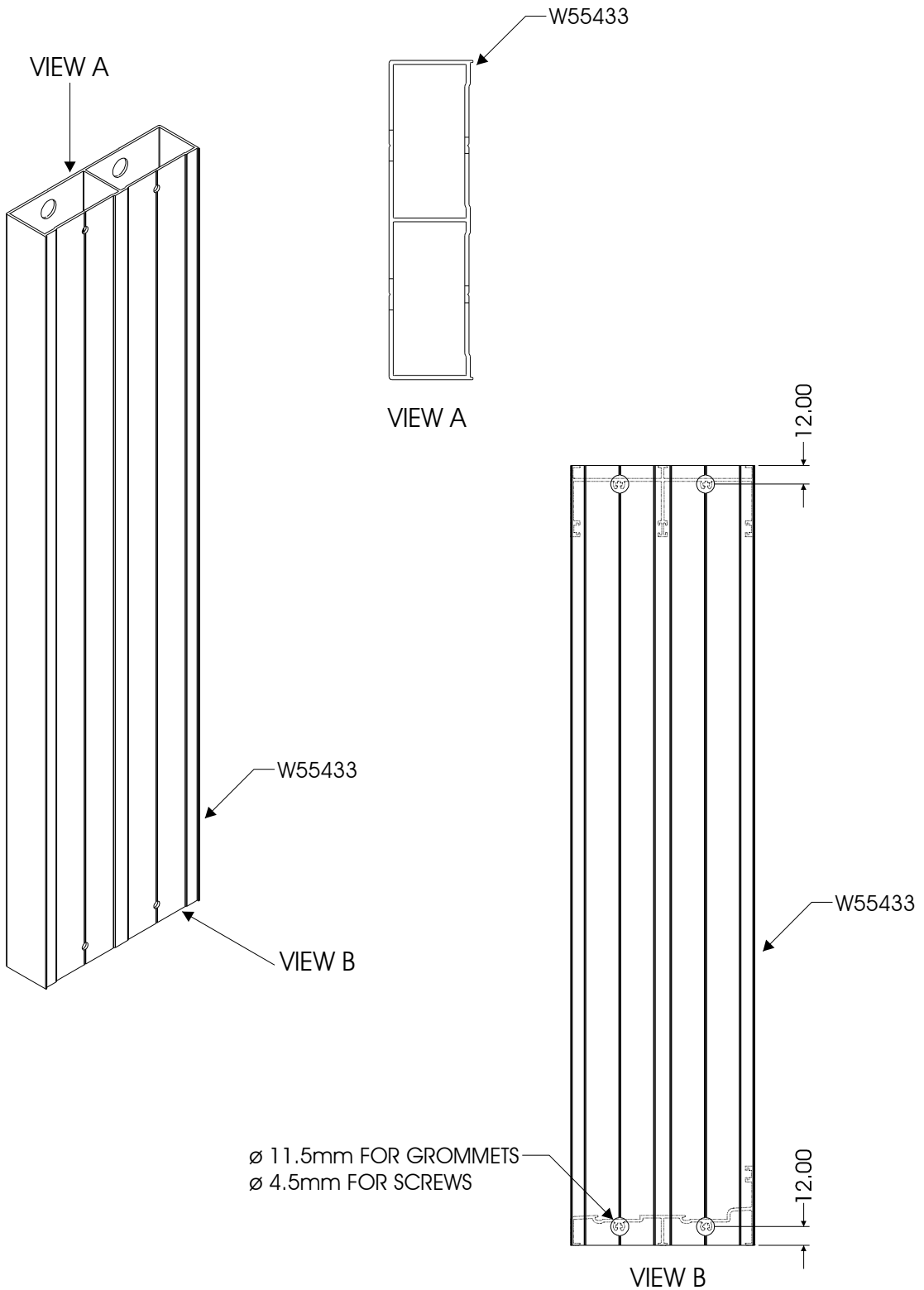

PALACE HIGH PERFORMANCE
 SLIDING DOOR
 TRIPLE JAMB
 MACHINING DETAIL

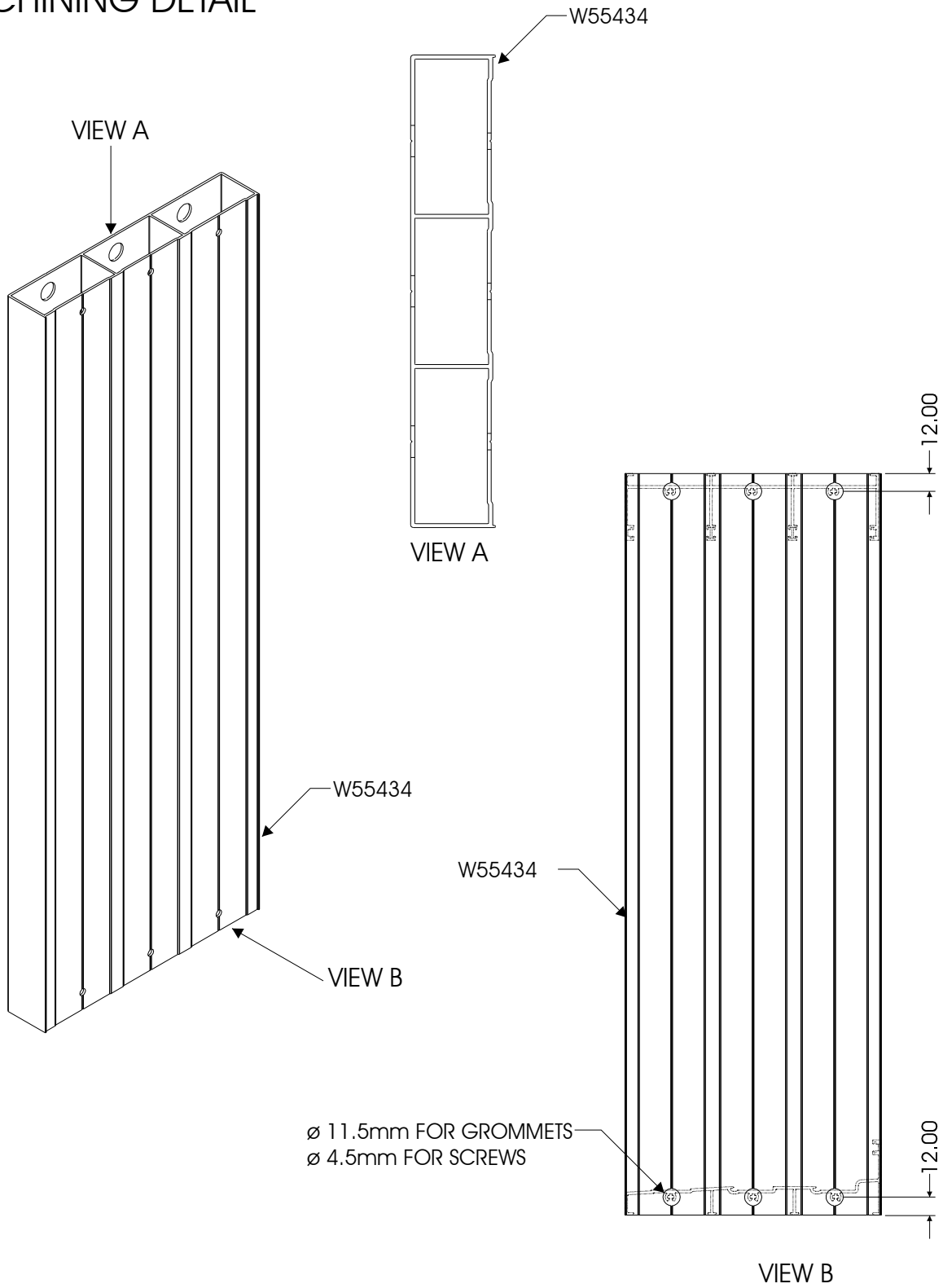

PALACE HIGH PERFORMANCE
SLIDING DOOR
SILL COVER
MACHINING DETAIL

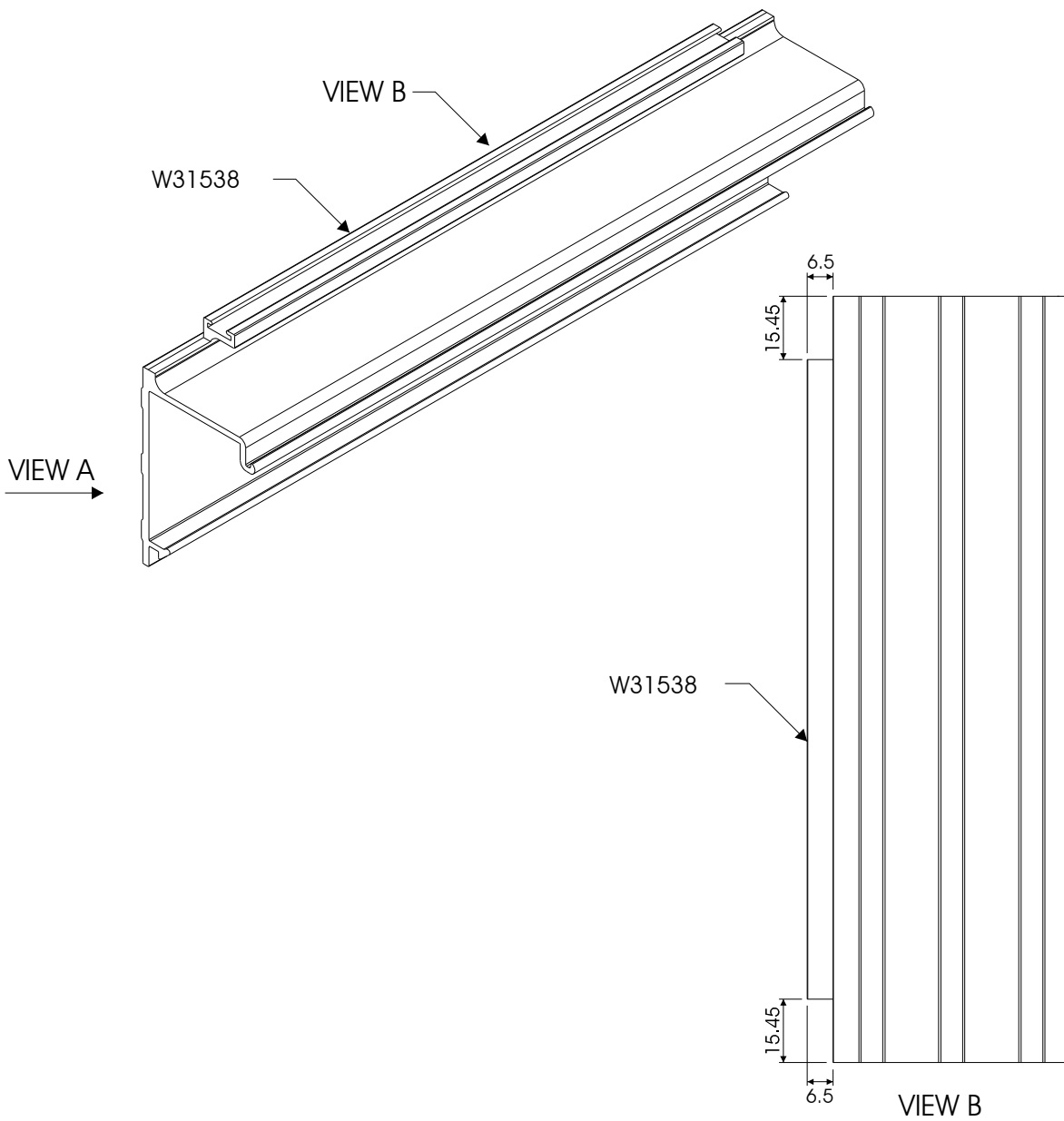
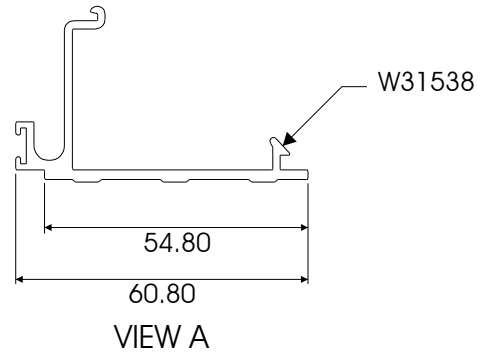

PALACE HIGH PERFORMANCE
SLIDING DOOR
TRIPLE JAMB ADAPTOR
MACHINING DETAIL

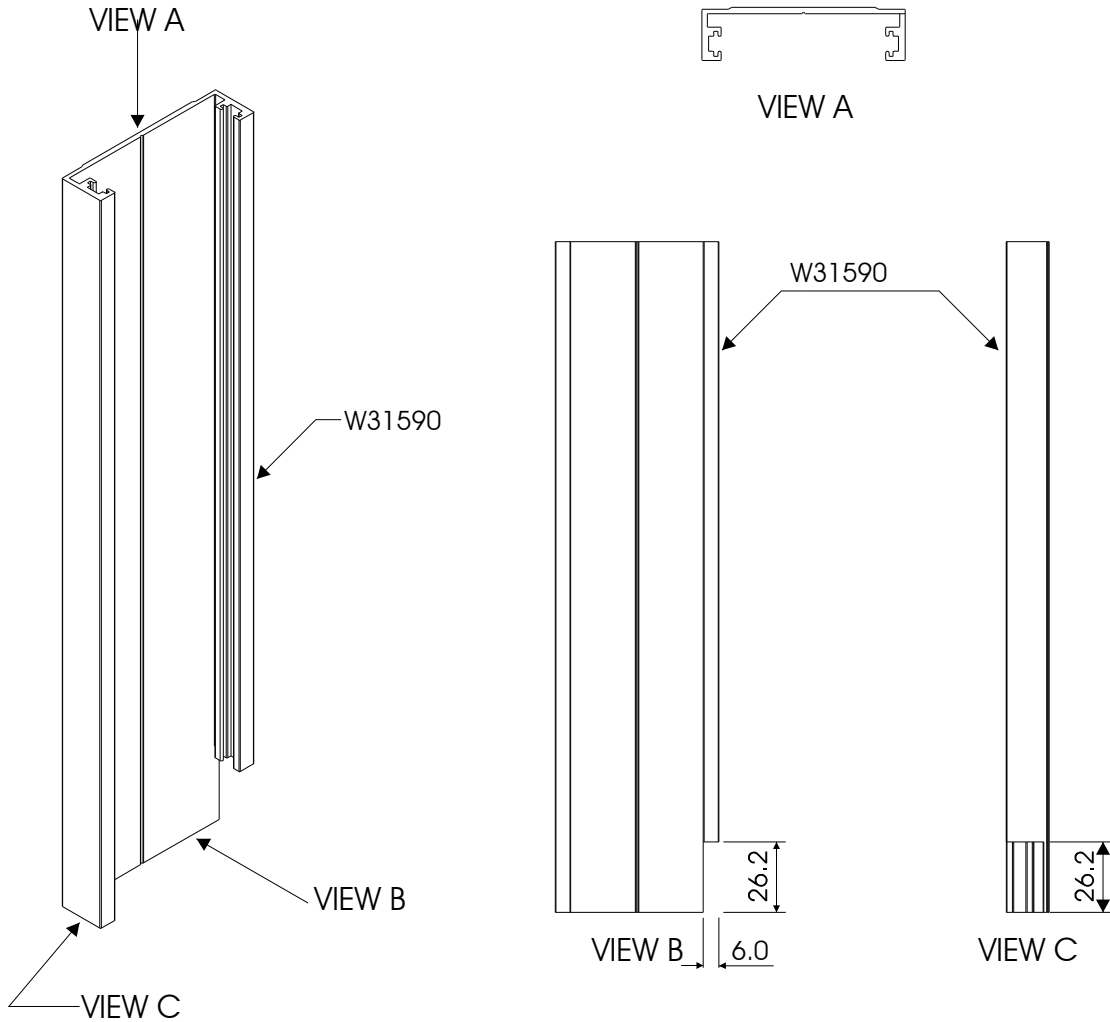

TO BE CUT OUT ON INSIDE ADAPTOR ONLY

OX & 2 PANEL MULTI
SLIDER = 1 SIDE ONLY

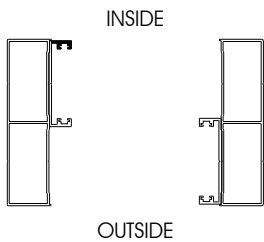

OXXO & 4 PANEL MULTI
SLIDER = BOTH SIDES

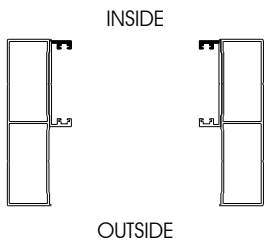

OXX & 3 PANEL MULTI
SLIDER = 1 SIDE ONLY

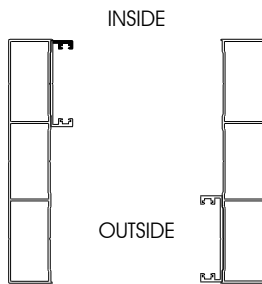

OXXXXO & 6 PANEL MULTI
SLIDER = BOTH SIDES

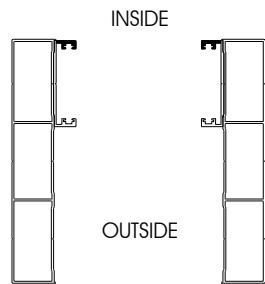

PALACE HIGH PERFORMANCE
 SLIDING DOOR
 HEAD/SILL RAIL
 MACHINING DETAIL TO SUIT
 ALL COMBINATIONS

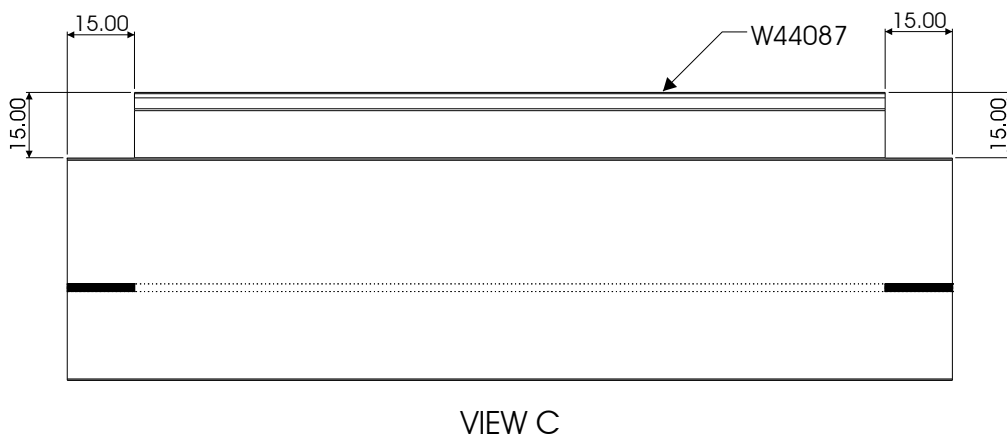
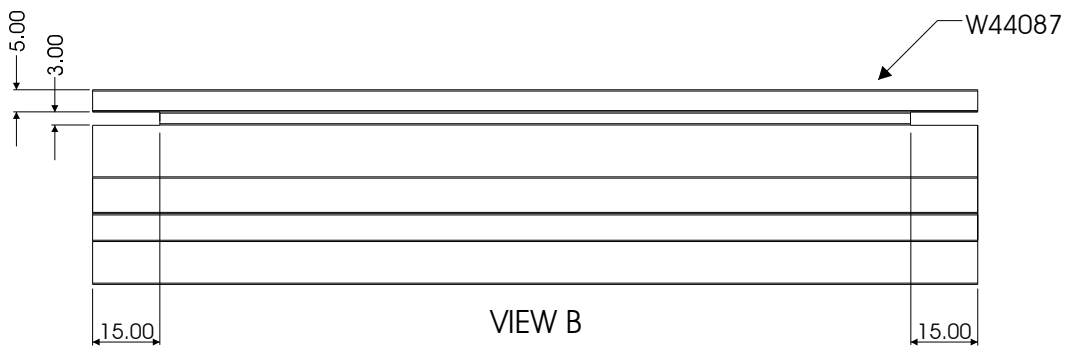
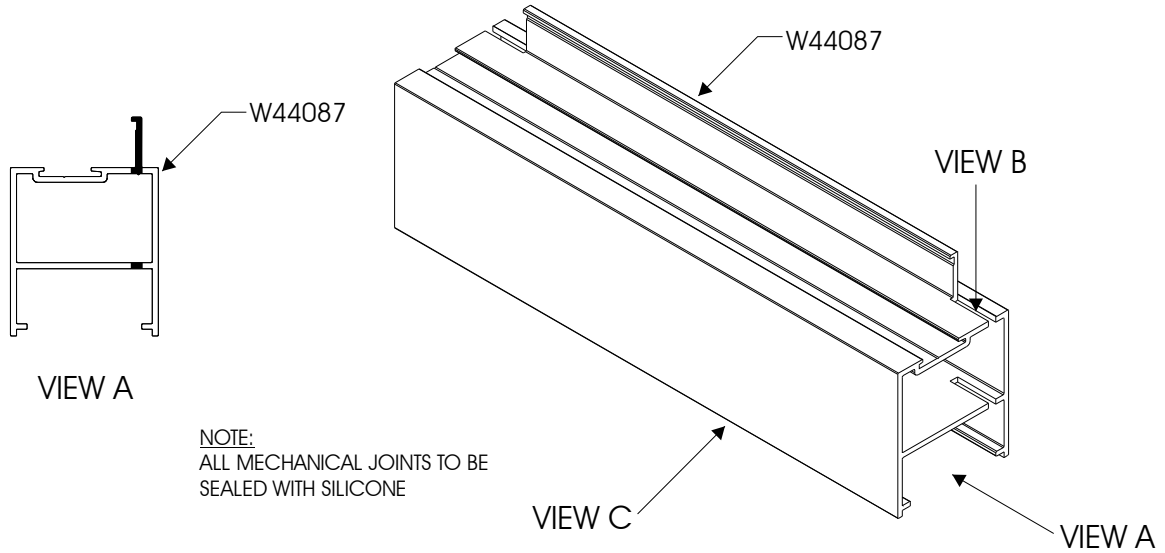

PALACE HIGH PERFORMANCE SLIDING DOOR SILL COMBINATIONS

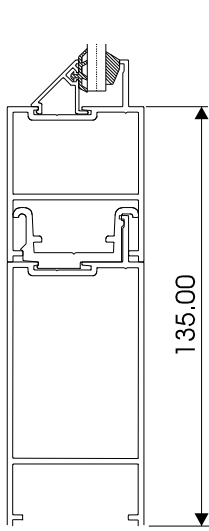

R7 + R4
(W44087 + W44088)

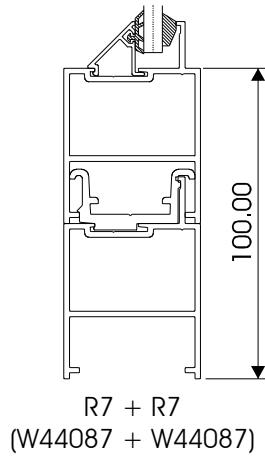

R7 + R7
(W44087 + W44087)

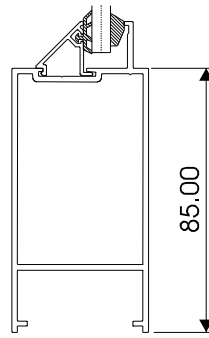

R4
(W44088)

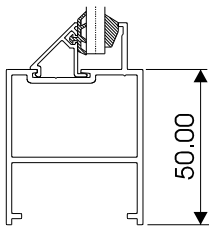
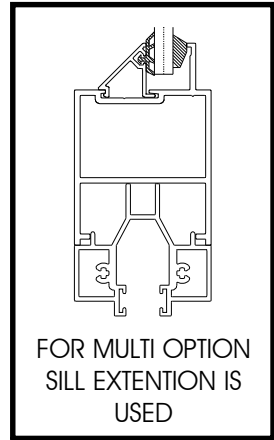

R7
(W44087)

NOTE:
ALL MECHANICAL JOINTS TO BE
SEALED WITH SILICONE

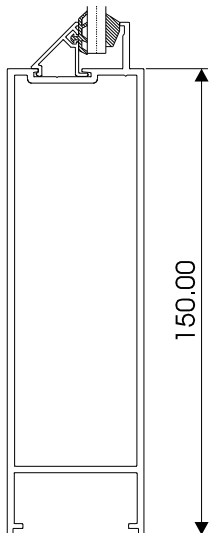

R6
(W44094)

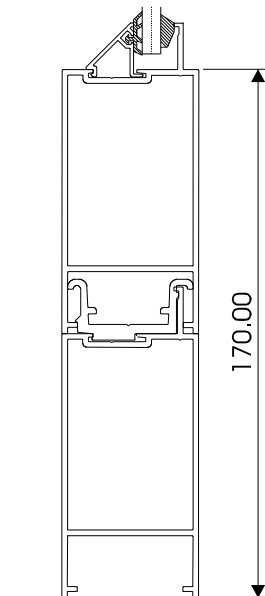

R4 + R4
(W44088 + W44088)

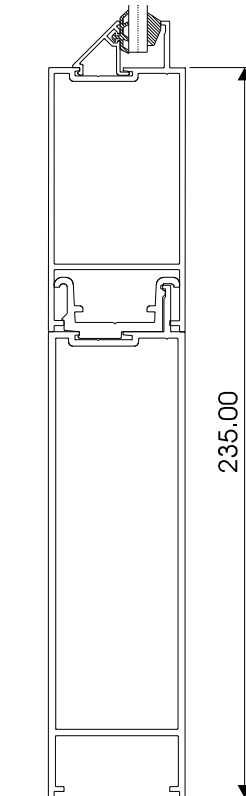

R4 + R6
(W44088 + W44094)

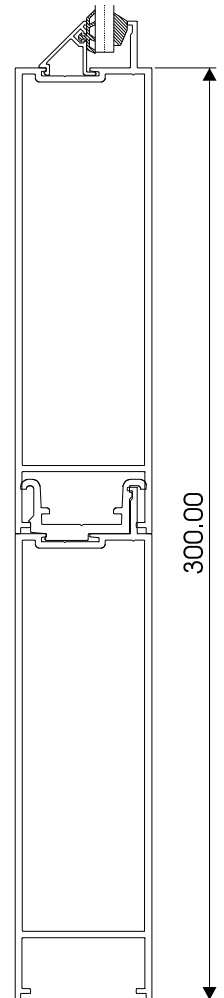

R4 + R6
(W44088 + W44094)

PALACE HIGH PERFORMANCE
SLIDING DOOR
MIDRAIL MACHINING DETAIL
TO SUIT ALL COMBINATIONS

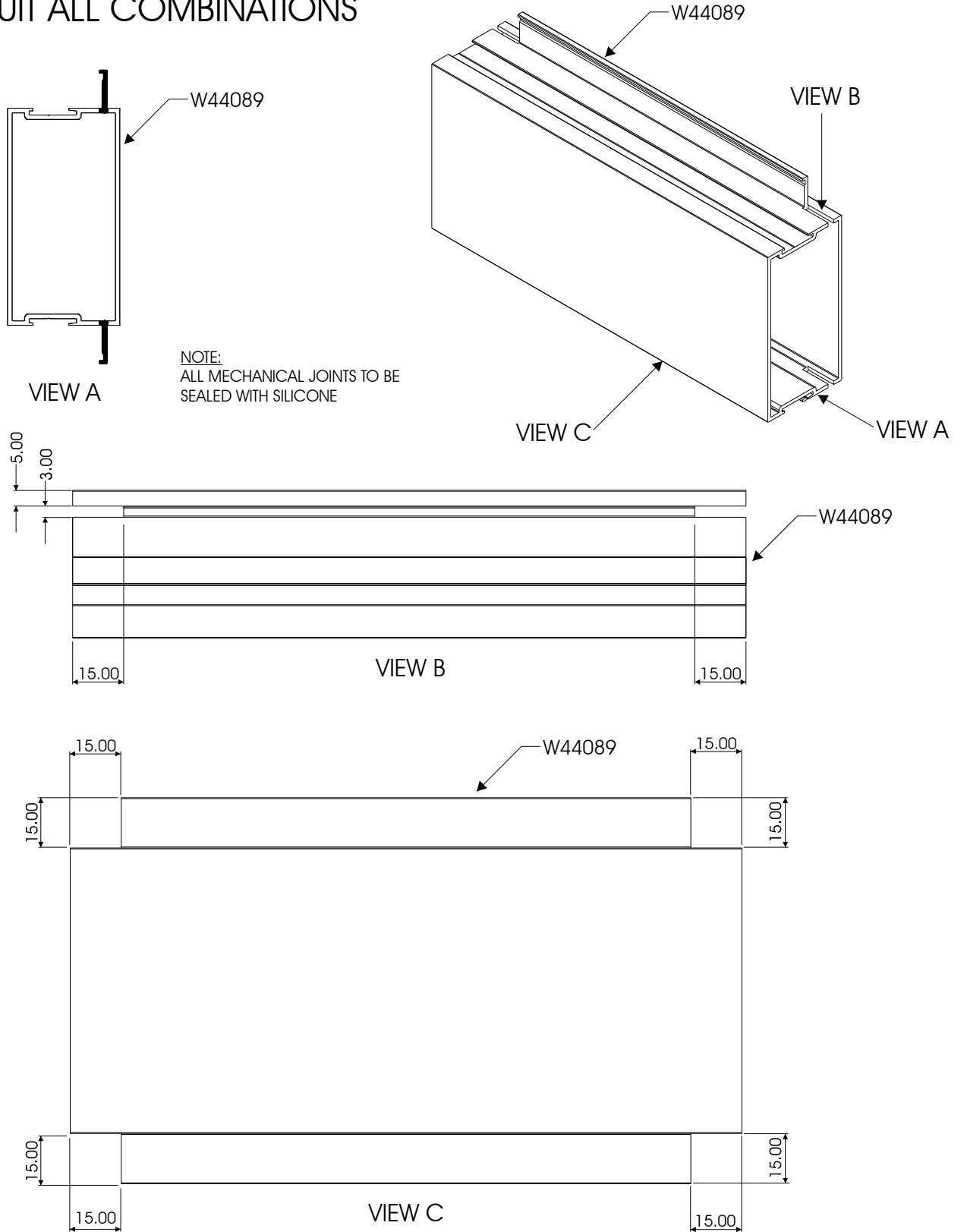

PALACE HIGH PERFORMANCE
 SLIDING DOOR
 R4 FILLER ADAPTOR
 MACHINING DETAIL

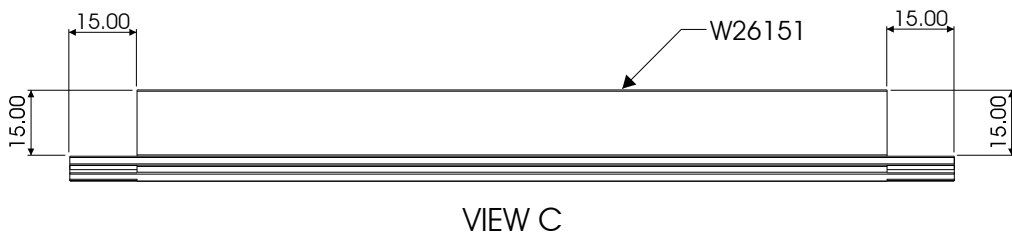
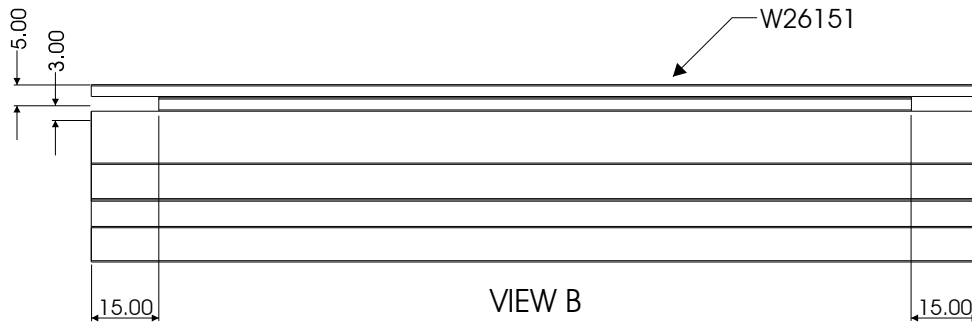
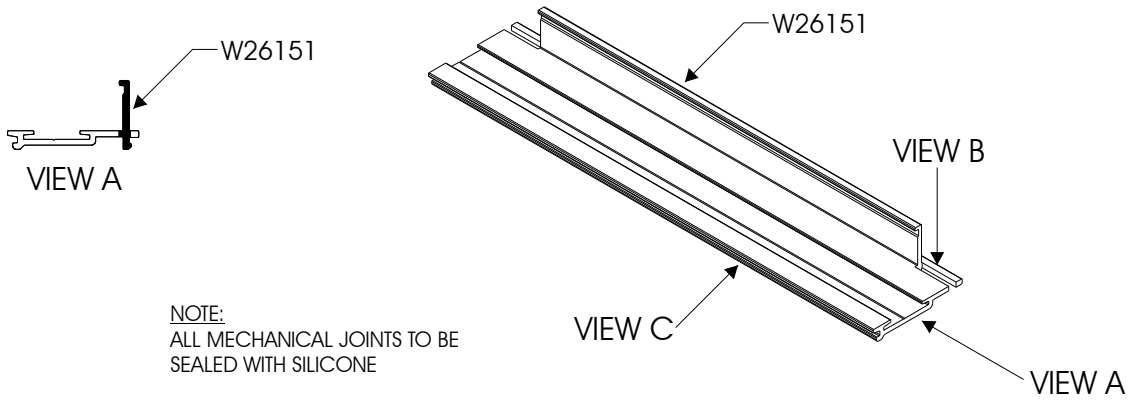

PALACE HIGH PERFORMANCE SLIDING DOOR MIDRAIL COMBINATIONS

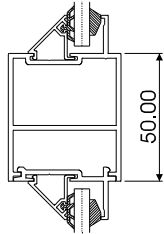

R7 + R4 FILLER
(W44087 + W26151)

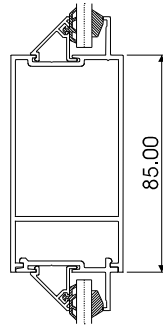

R4 + R4 FILLER
(W44088 + W26151)

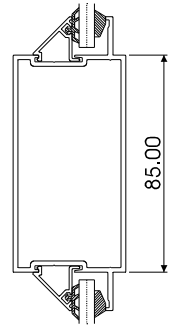

R4SP
(W44089)

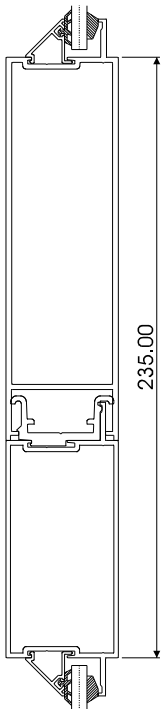

R6 + R4SP
(W44094 + W44089)

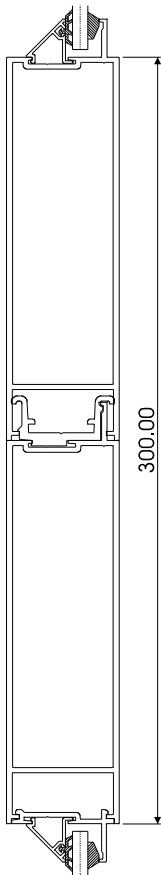

R6 + R6 + R4 FILLER
(W44094 + W44094 + W44094 +
W26151)

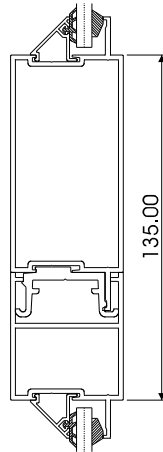

R7 + R4SP
(W44087 + W44089)

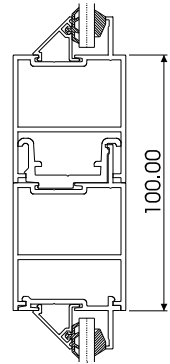

R7 + R7 + R4 FILLER
(W44087 + W44087 +
W26151)

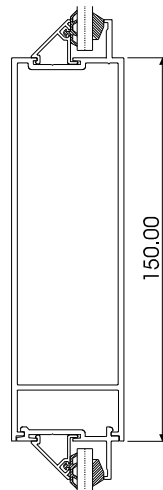

R6 + R4 FILLER
(W44094 + W26151)

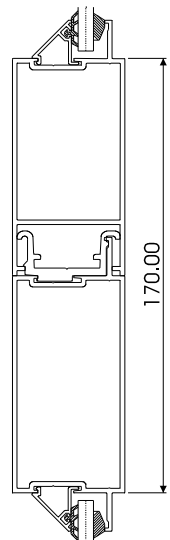

R4 + R4SP
(W44088 + W44089)

NOTE:
ALL MECHANICAL JOINTS TO BE
SEALED WITH SILICONE

PALACE HIGH PERFORMANCE
 SLIDING DOOR
 FIXED INTERLOCKER
 MACHINING DETAIL

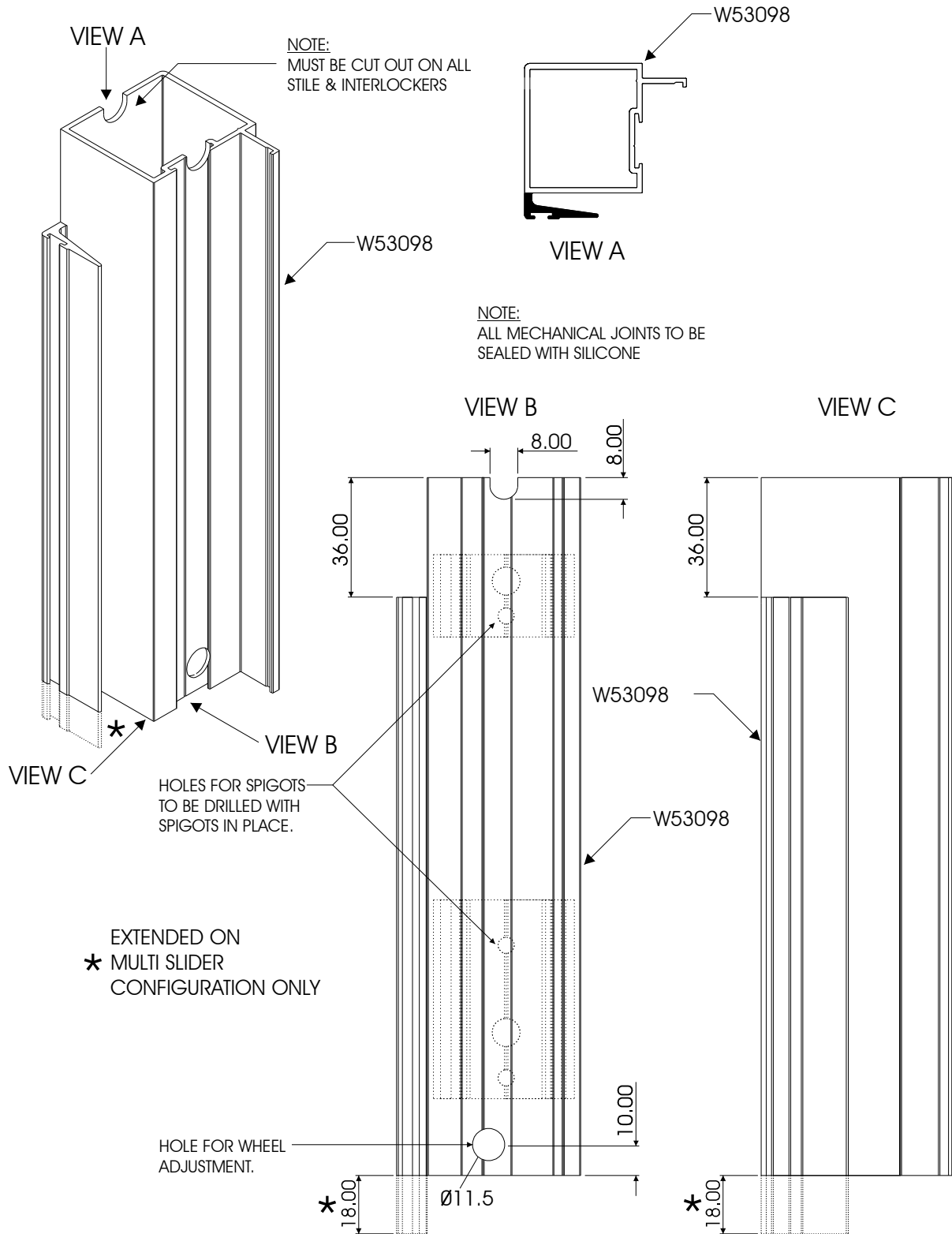

PALACE HIGH PERFORMANCE
 SLIDING DOOR
 SLIDING INTERLOCKER
 MACHINING DETAIL

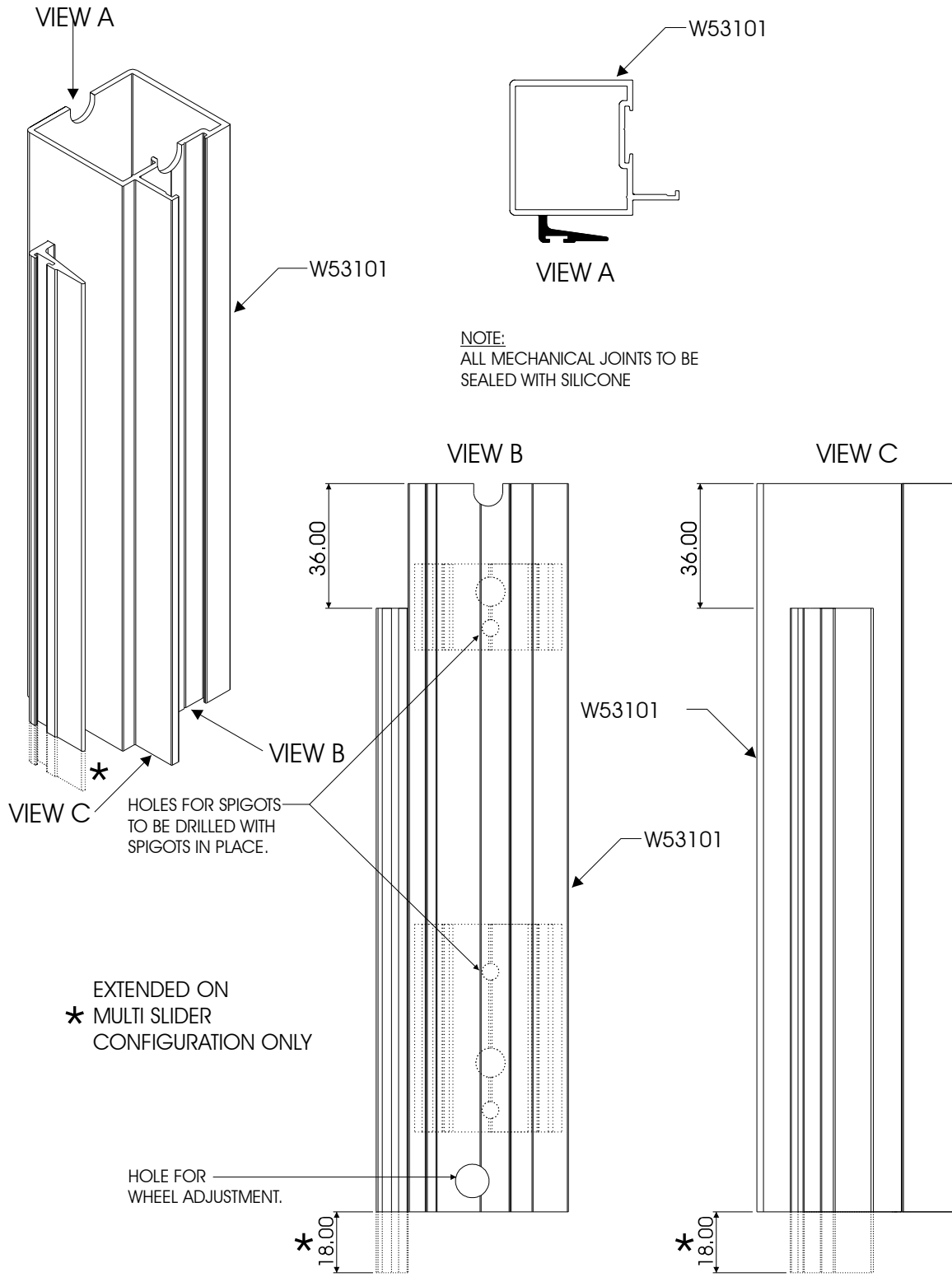

PALACE HIGH PERFORMANCE
 SLIDING DOOR
 FIXED HEAVY DUTY
 INTERLOCKER
 MACHINING DETAIL

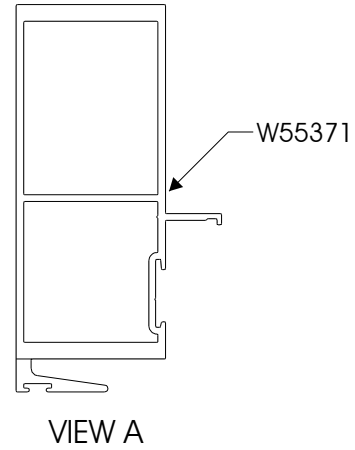
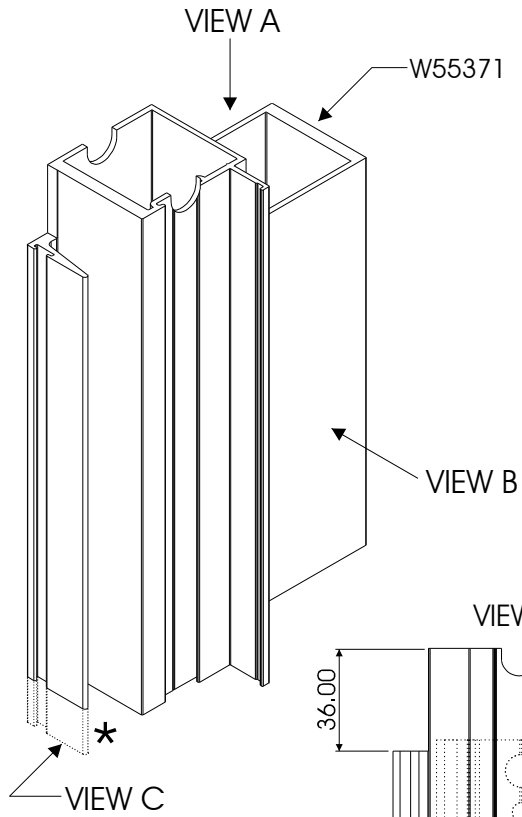

NOTE:
 ALL MECHANICAL JOINTS TO BE
 SEALED WITH SILICONE

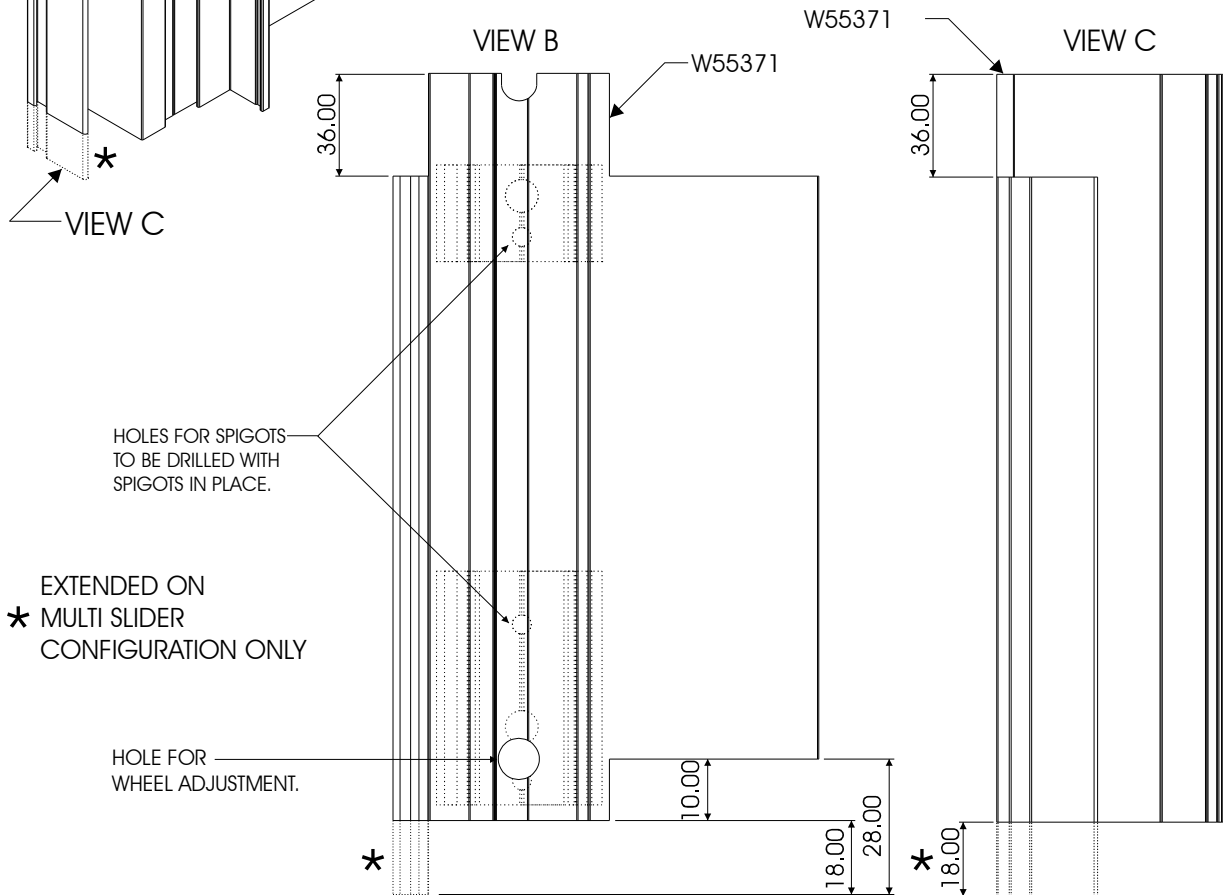

PALACE HIGH PERFORMANCE
 SLIDING DOOR
 SLIDING HEAVY DUTY
 INTERLOCKER
 MACHINING DETAIL

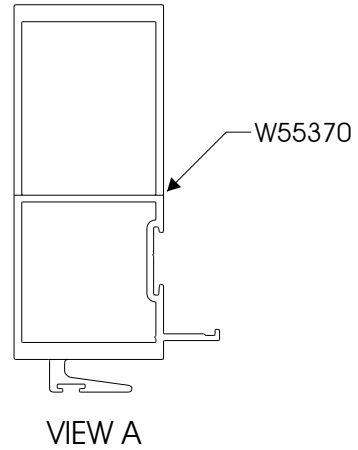
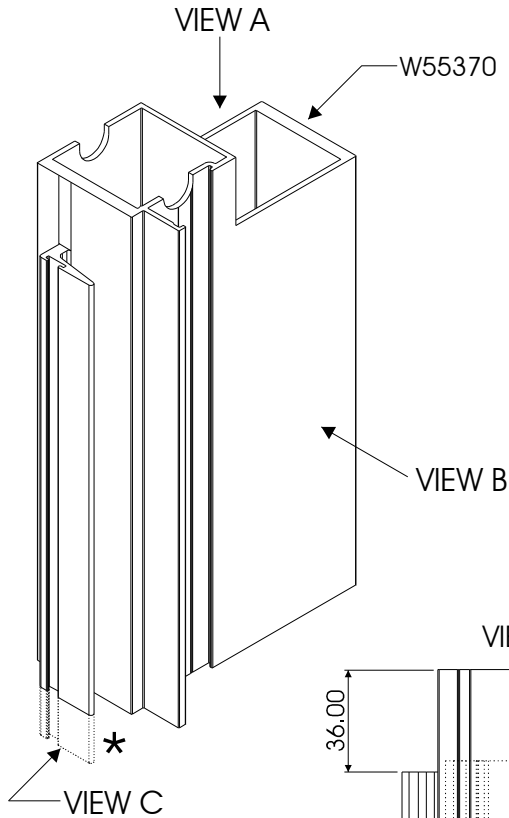

NOTE:
 ALL MECHANICAL JOINTS TO BE
 SEALED WITH SILICONE

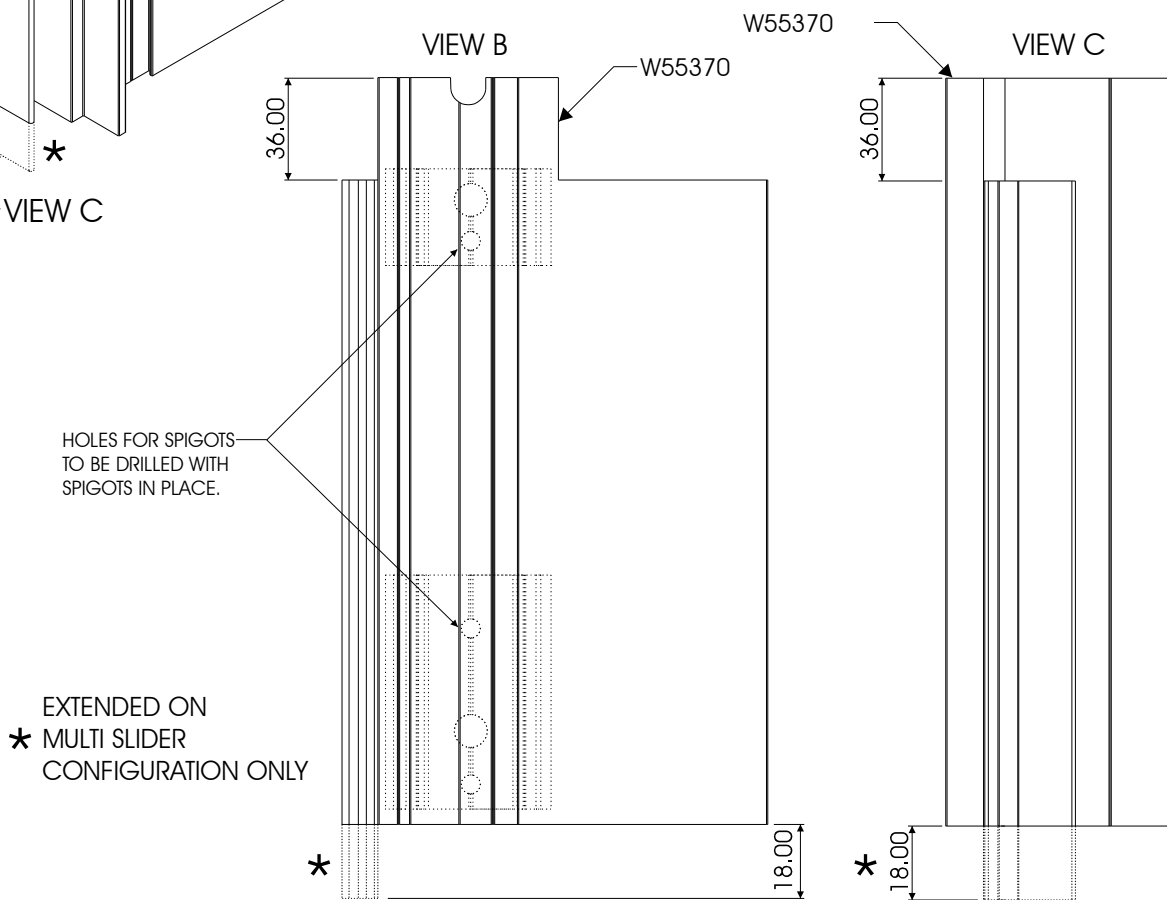

PALACE HIGH PERFORMANCE
 SLIDING DOOR
 90mm FIXED INTERLOCKER
 MACHINING DETAIL

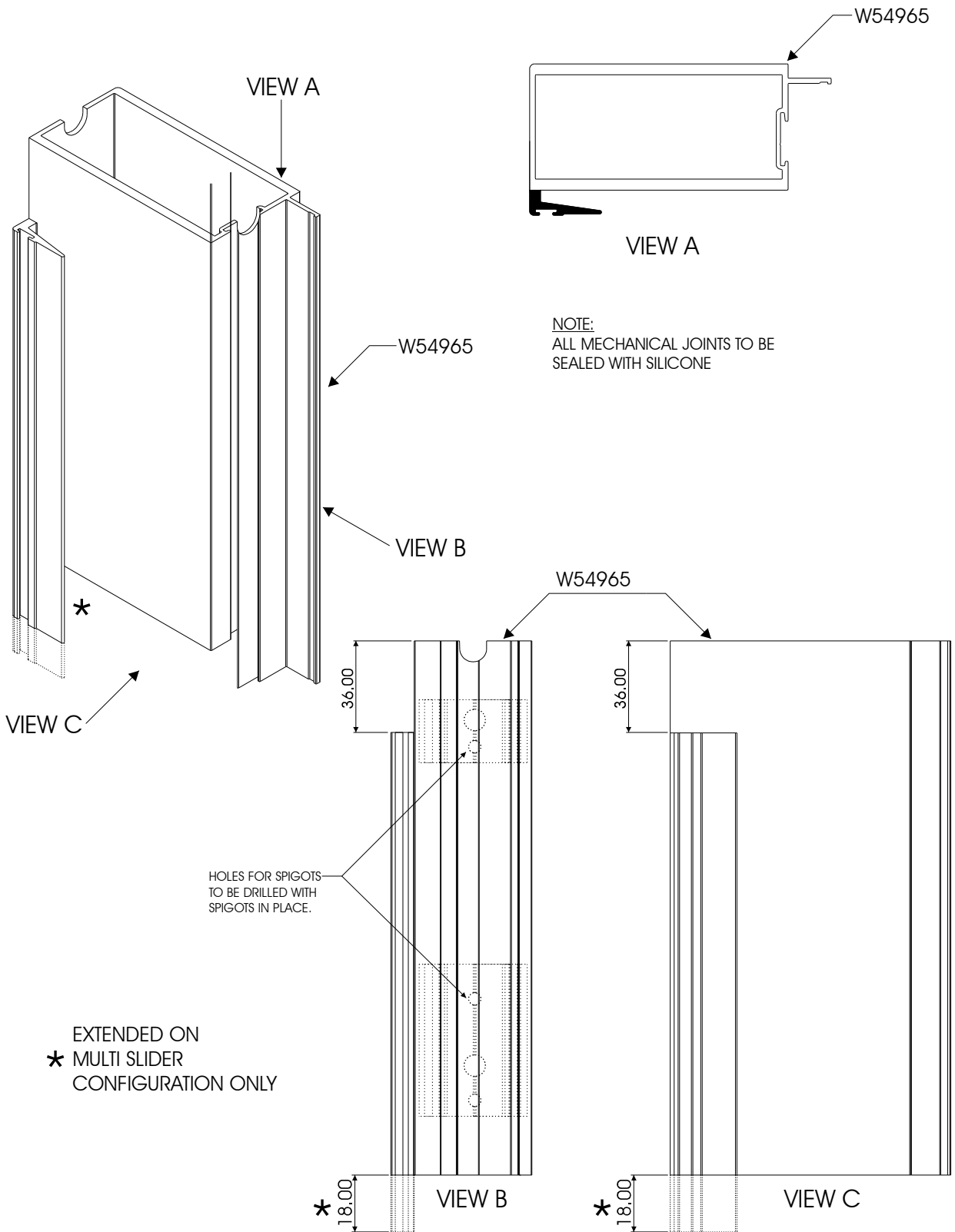

PALACE HIGH PERFORMANCE
 SLIDING DOOR
 SLIDING INTERLOCKER
 MACHINING DETAIL

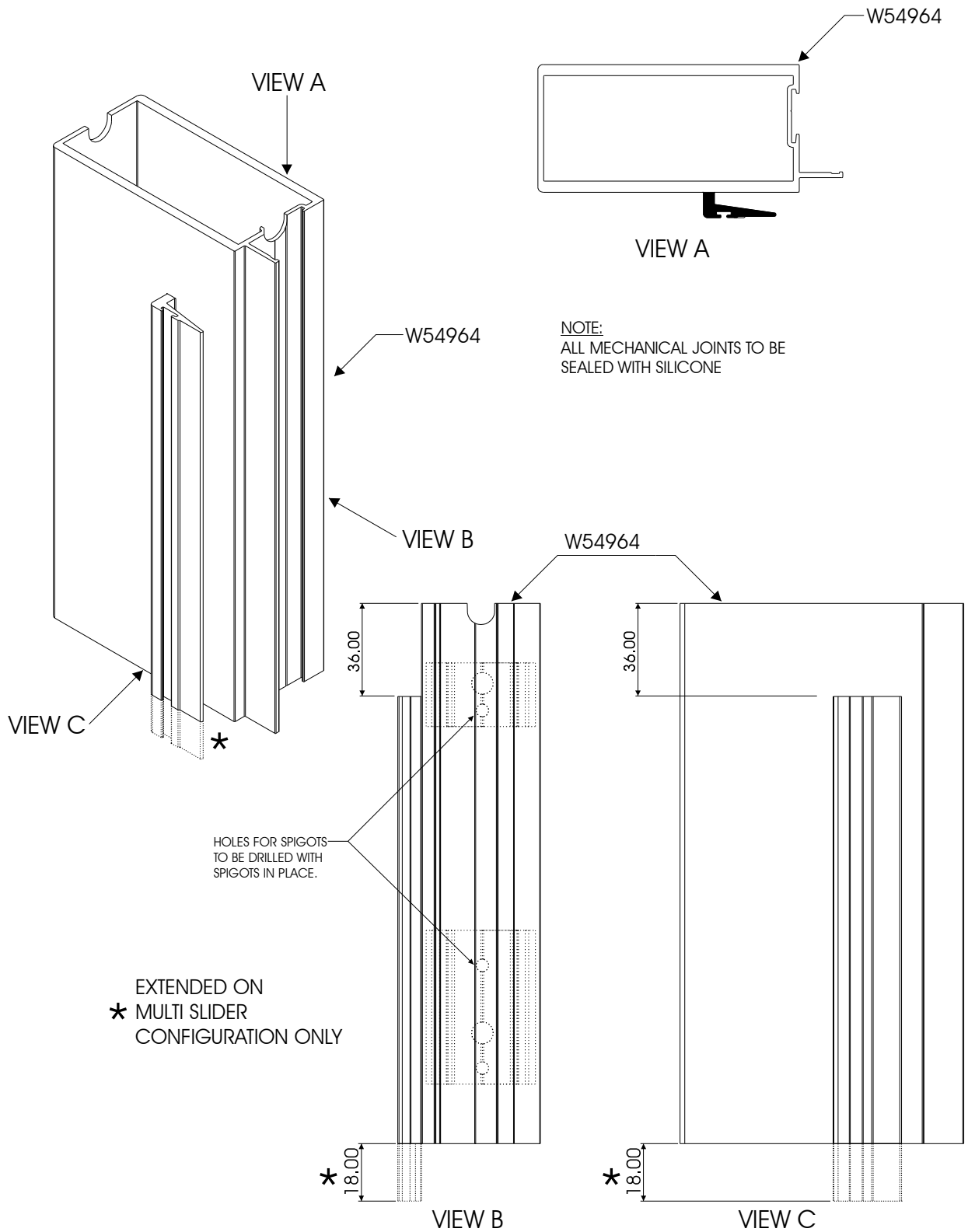

PALACE HIGH PERFORMANCE
SLIDING DOOR
ASTRAGAL MACHINING DETAIL

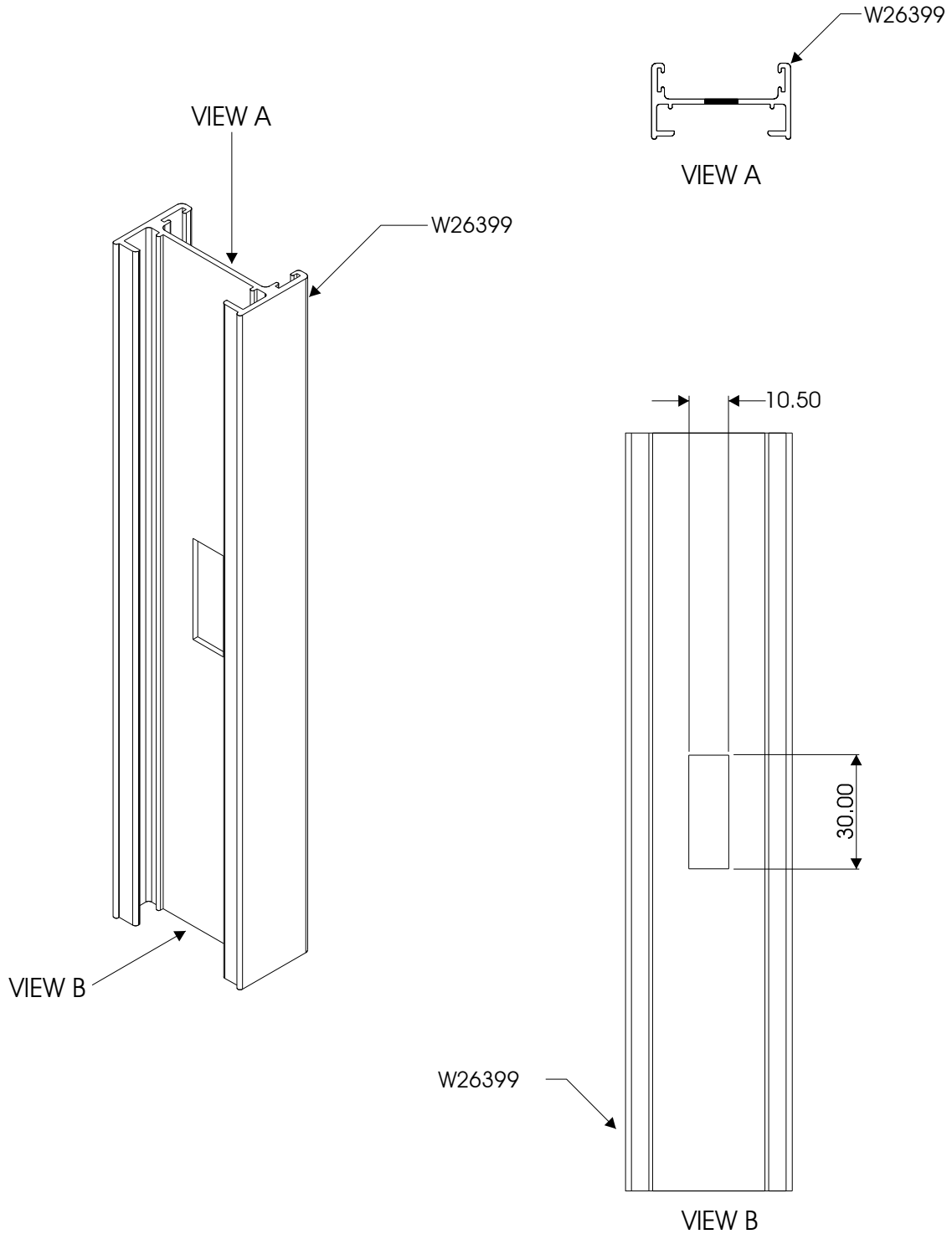

PALACE HIGH PERFORMANCE
 SLIDING DOOR
 HEAVY DUTY ASTRAGAL
 MACHINING DETAIL
 FOR OX, OXXO, OXX & OXXXXO

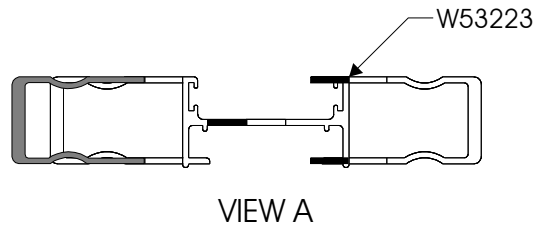
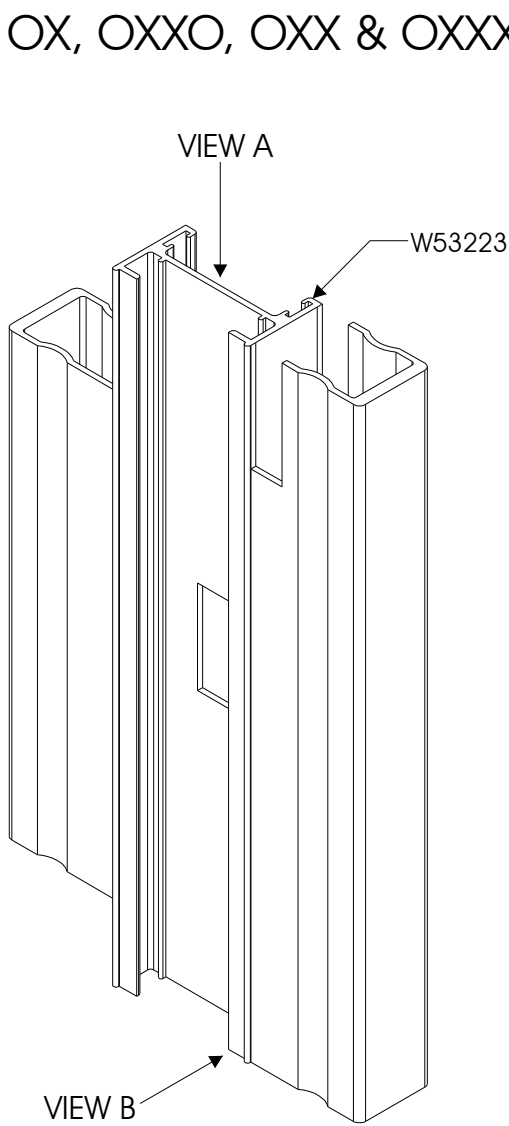

NOTE: SHARP MACHINED EDGES
 TO BE ROUNDED TO
 PREVENT UNDUE WOOLPILE
 WEAR.

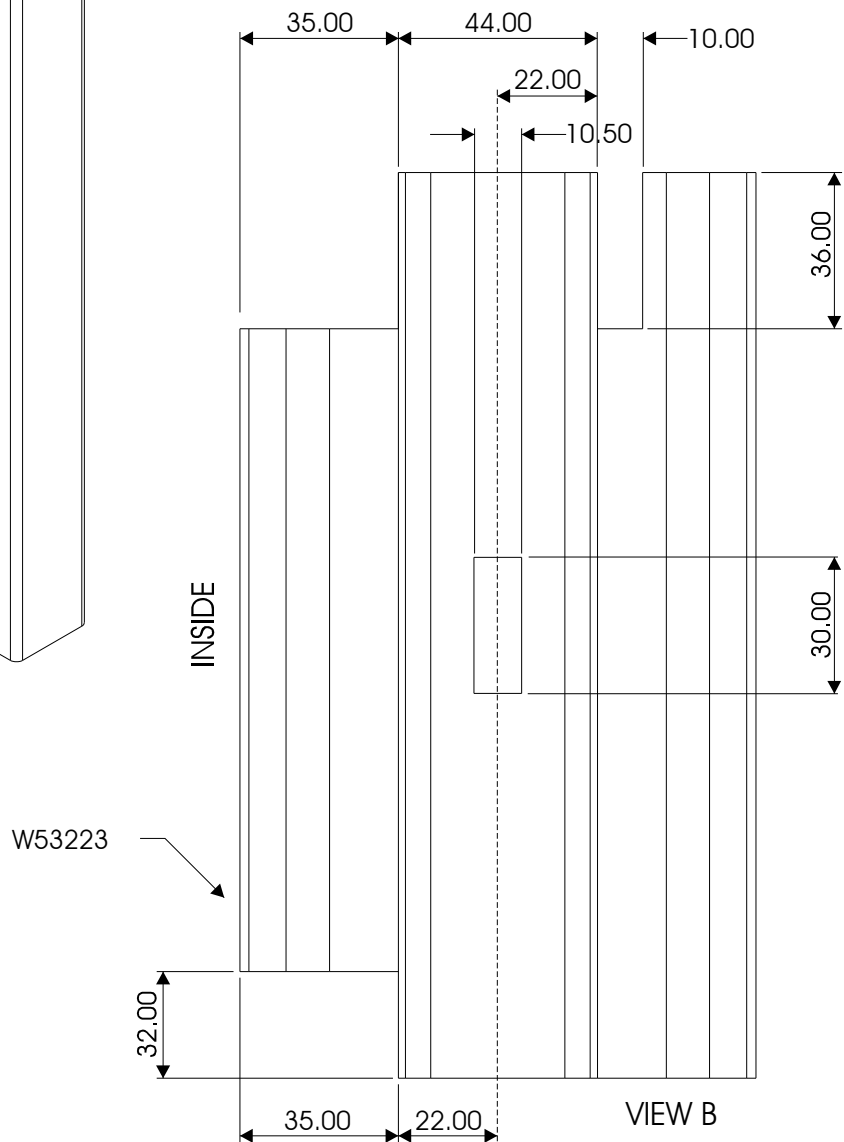

PALACE HIGH PERFORMANCE
 SLIDING DOOR
 HEAVY DUTY ASTRAGAL
 MACHINING DETAIL
 FOR XX, XXX, XXXX & XXXXXXXX

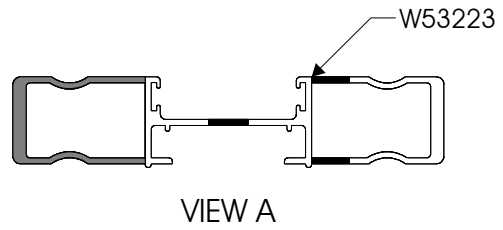
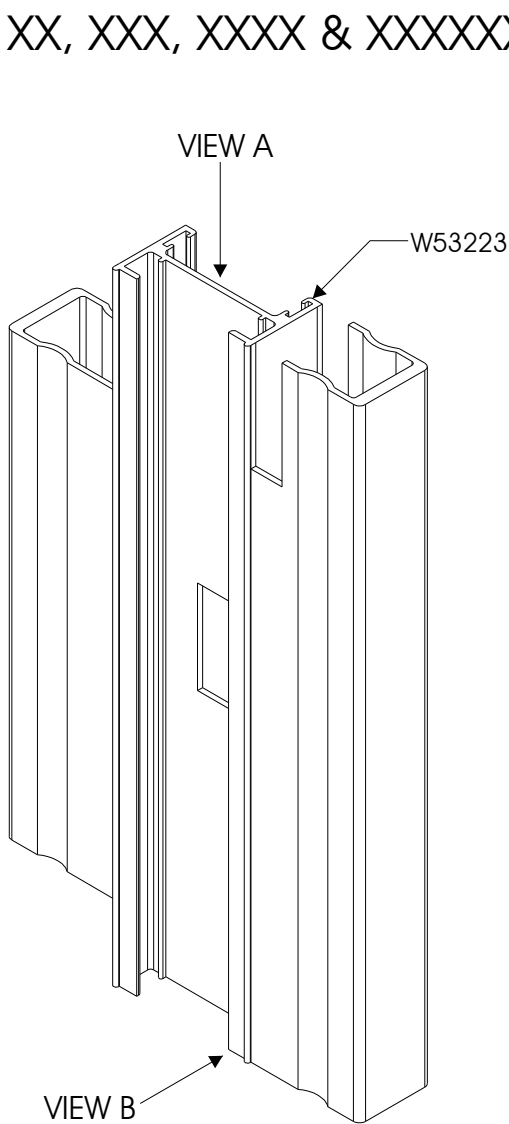

NOTE: SHARP MACHINED EDGES
 TO BE ROUNDED TO
 PREVENT UNDUE WOOLPILE
 WEAR.

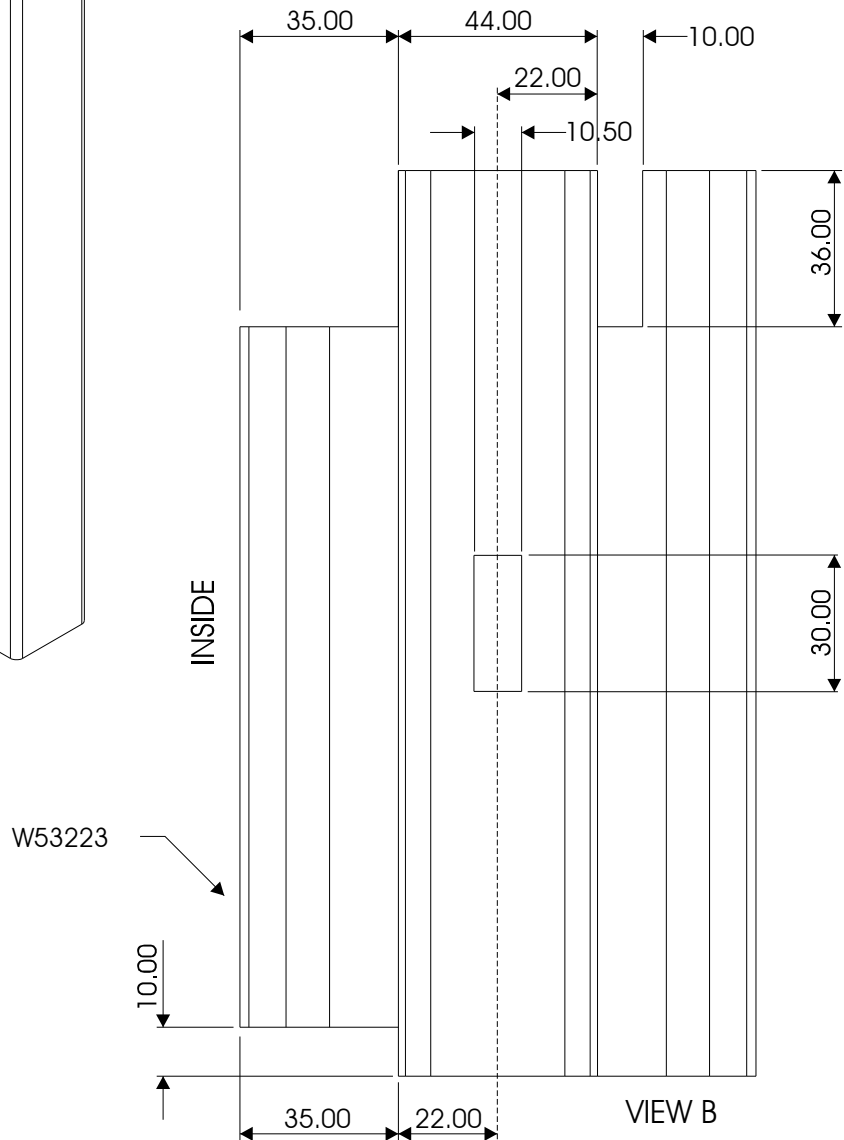

PALACE HIGH PERFORMANCE SLIDING DOOR SPIGOT MACHINING DETAIL

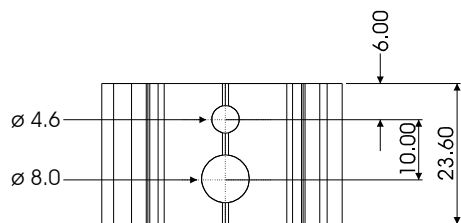
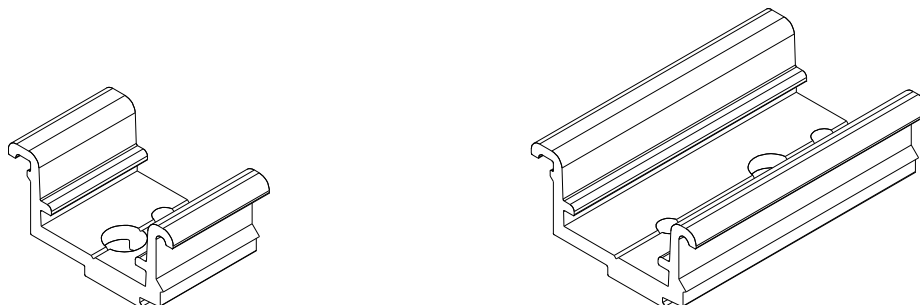

TO ACCEPT W44087
HEAD RAIL

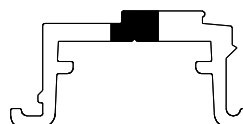
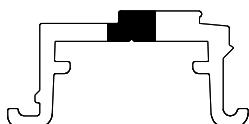
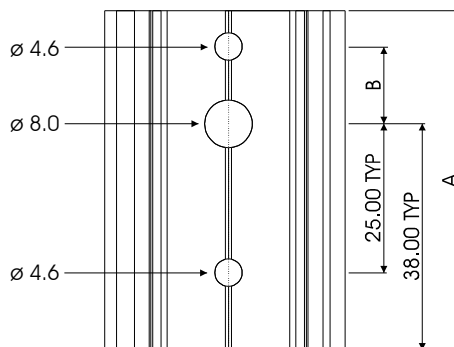

SECTION	DIM A	DIM B
W44088 BOTTOM RAIL	56.8	11
W44094 BOTTOM RAIL	123.2	50
W44089 MIDRAIL	76	30

PALACE HIGH PERFORMANCE
SLIDING DOOR
HANDLE MACHINING DETAIL

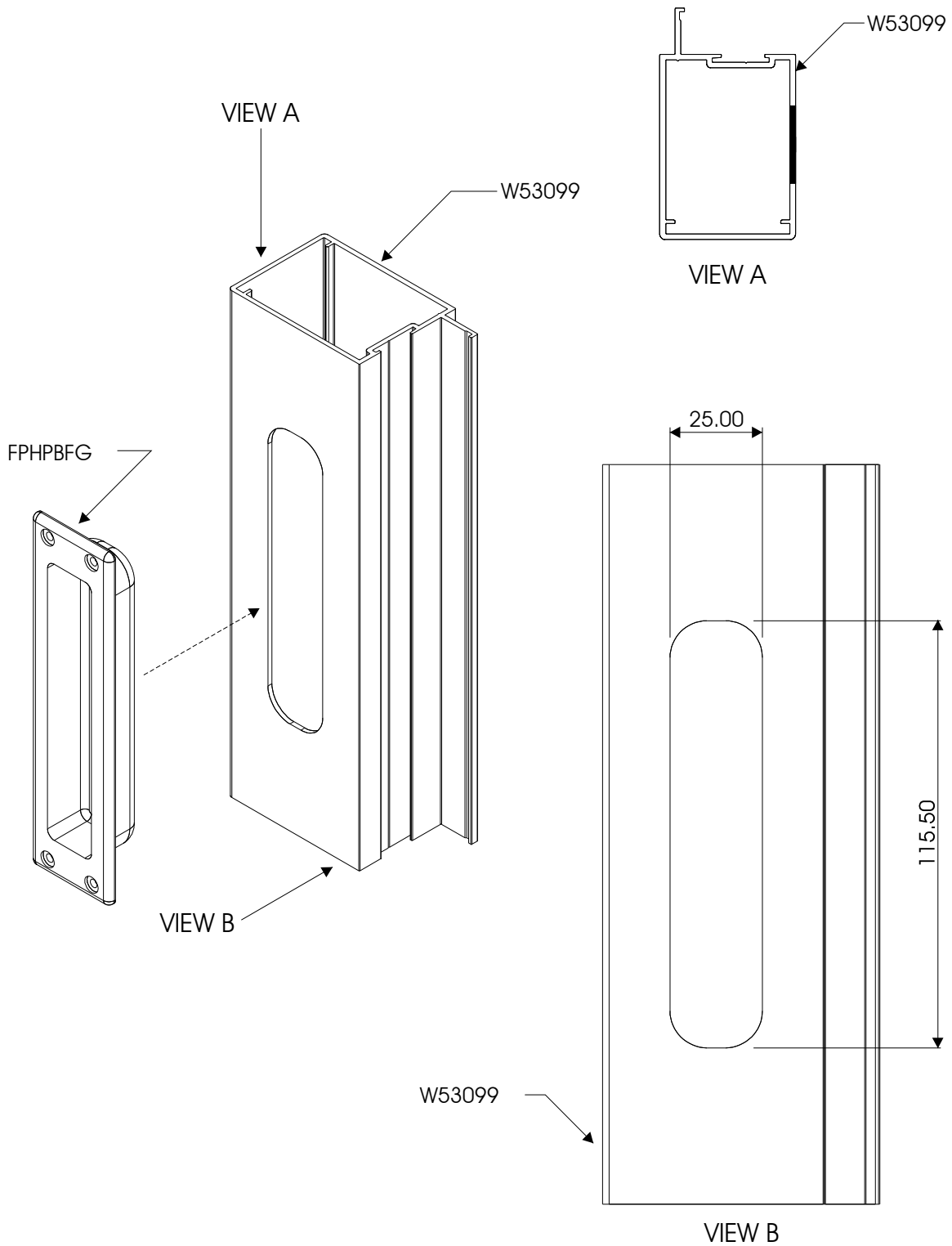

PALACE HIGH PERFORMANCE
SLIDING DOOR
LOCK MACHINING DETAIL
ON MEETING STILE

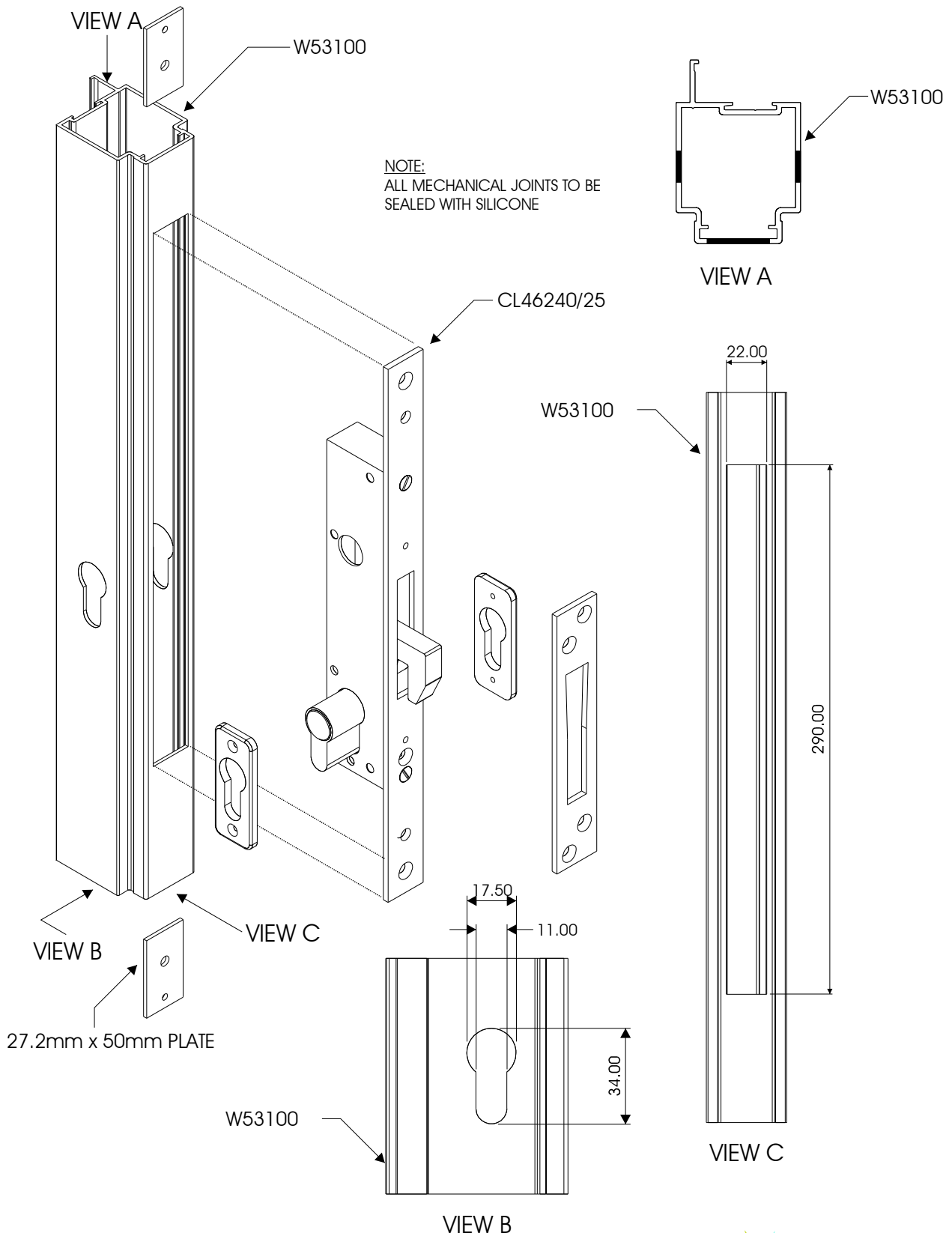

PALACE HIGH PERFORMANCE
 SLIDING DOOR
 LOCK MACHINING DETAIL
 ON DOOR STILE TO SUIT
 ALL COMBINATIONS



NOTE:
 ALL MECHANICAL JOINTS TO BE
 SEALED WITH SILICONE

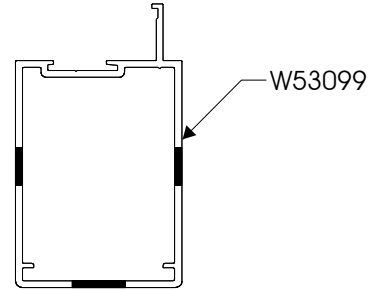
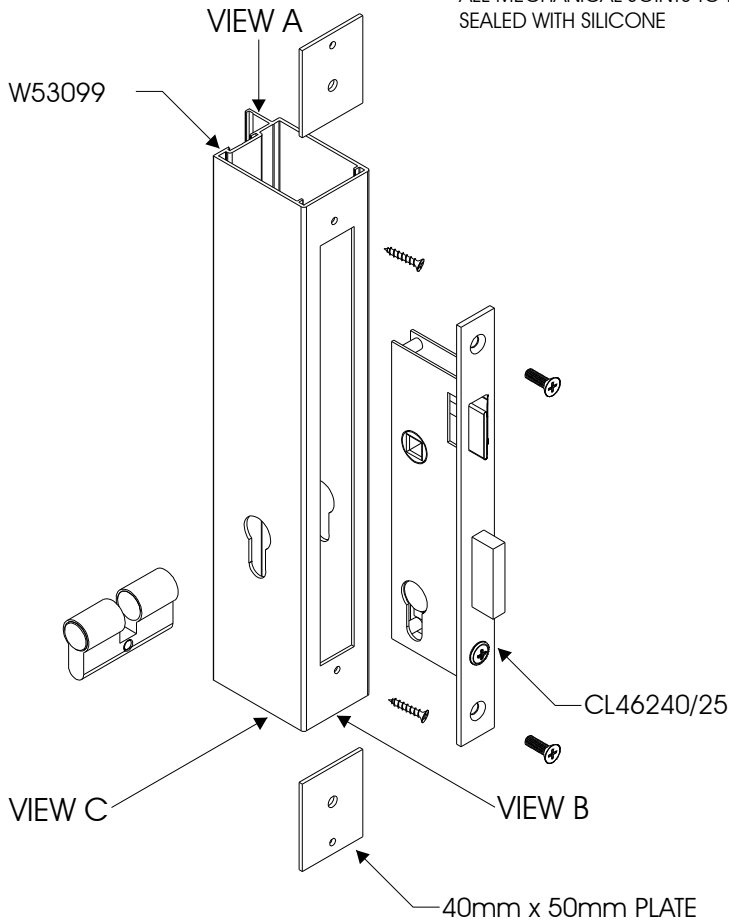

VIEW A

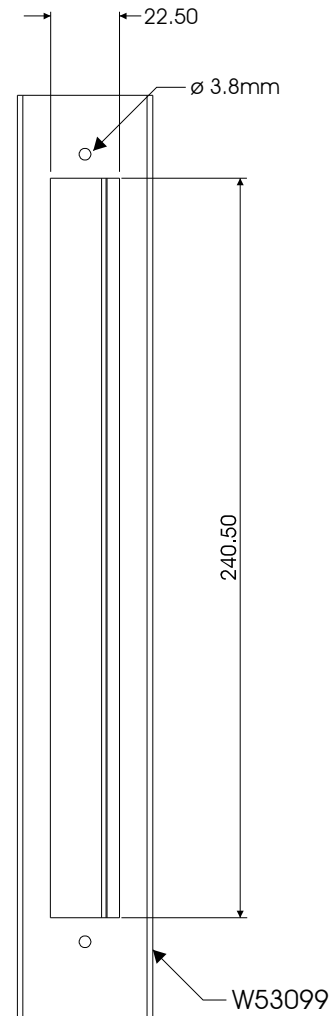

VIEW B

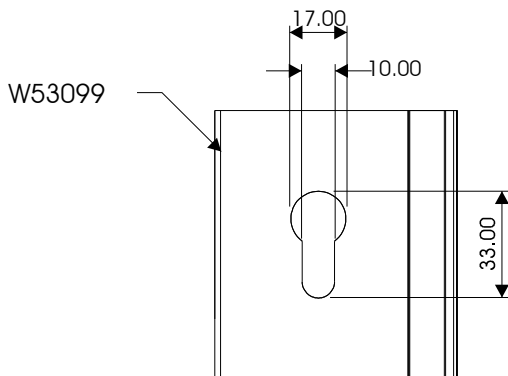

VIEW C

PALACE HIGH PERFORMANCE SLIDING DOOR ROLLER ASSEMBLY DETAIL

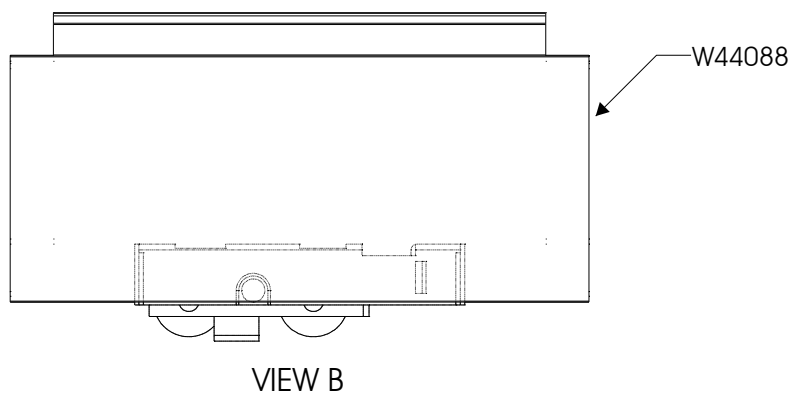
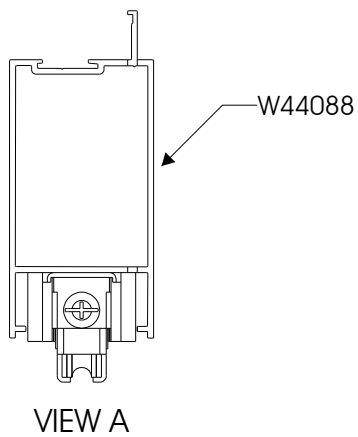
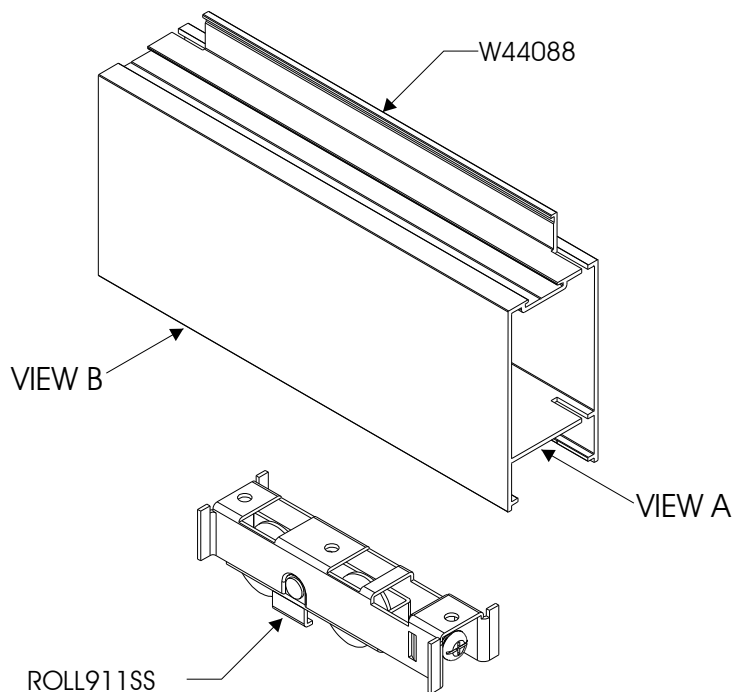

PALACE HIGH PERFORMANCE
SLIDING DOOR
ROLLER ASSEMBLY DETAIL
ON MULTI SLIDER

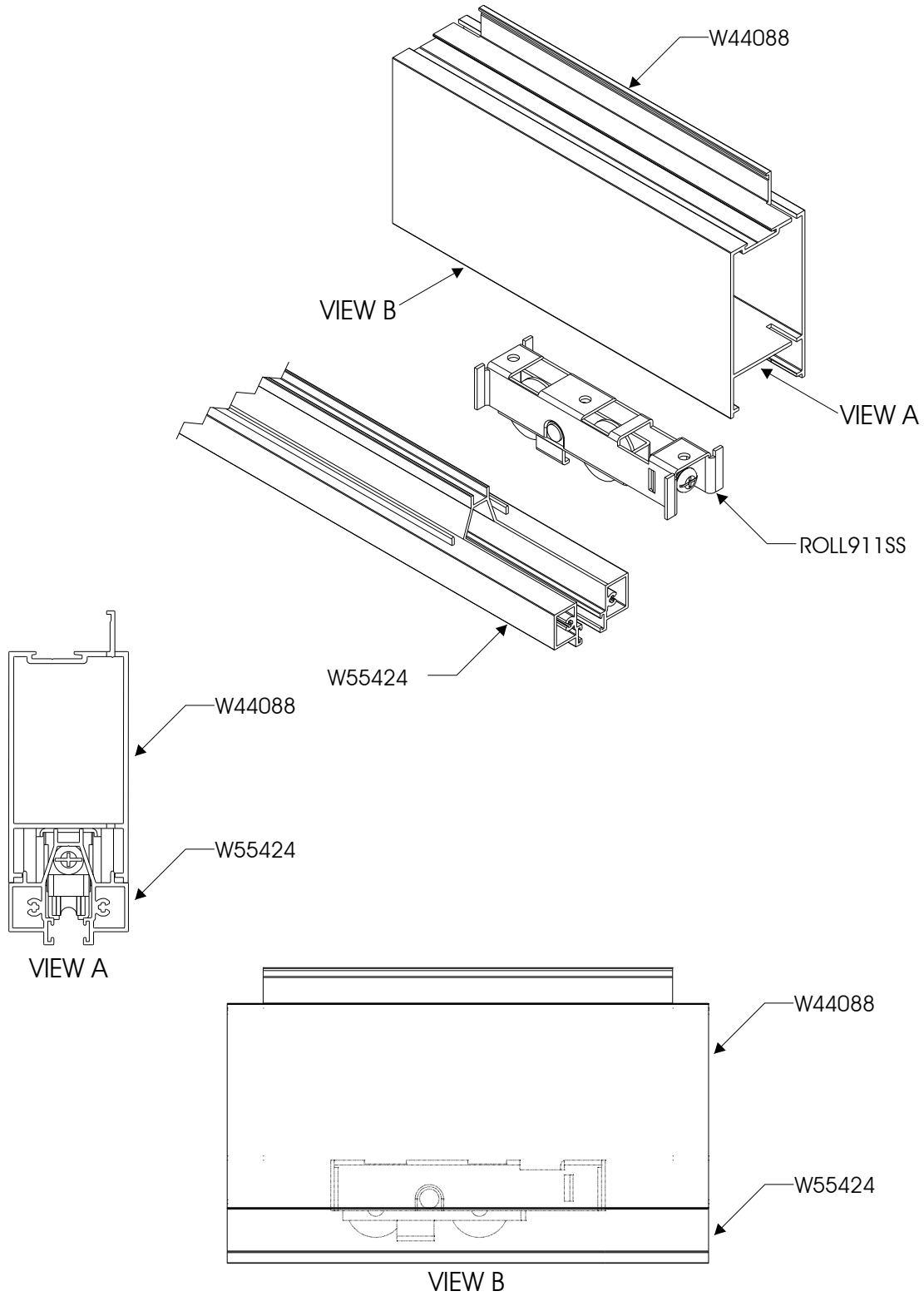

PALACE HIGH PERFORMANCE SLIDING DOOR ROD & SPIGOT ASSEMBLY DETAIL

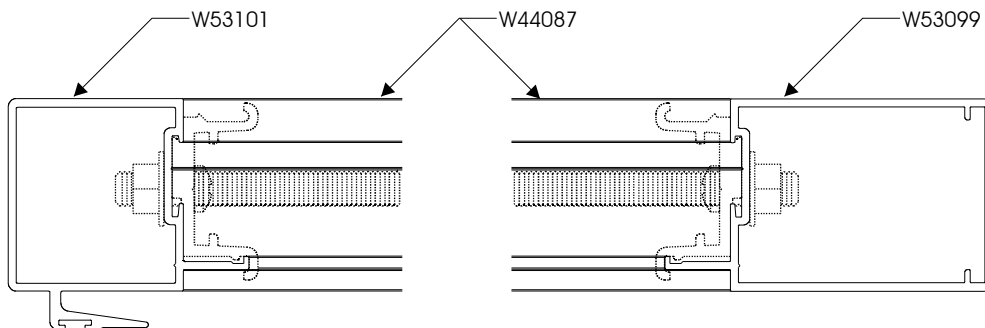
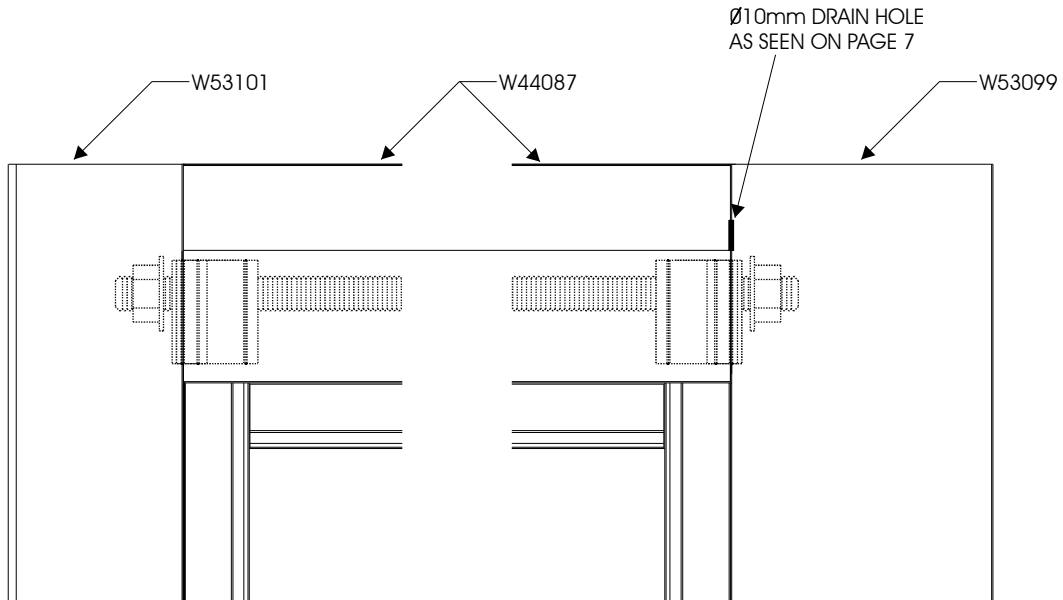

DETAIL TYPICAL TO HEAD AND SILL OF FIXED AND SLIDING LIGHTS

1. ATTACH SPIGOTS TO STILES WITH NO 8 FIXING SCREWS (STPPS830)
2. FASTEN STILES TO TOP AND BOTTOM RAILS WITH NUTS (NVT8MM) AND THREADED RODS (TR8MM). USE WASHERS (WSH8MM).
3. ENSURE ALL MATING JOINTS ARE BEDDED IN SEALANT BEFORE ASSEMBLY.

PALACE HIGH PERFORMANCE
 SLIDING DOOR
 STOPPER ASSEMBLY DETAIL
 FOR OX, XXX, OXXXXO & XXXXXX

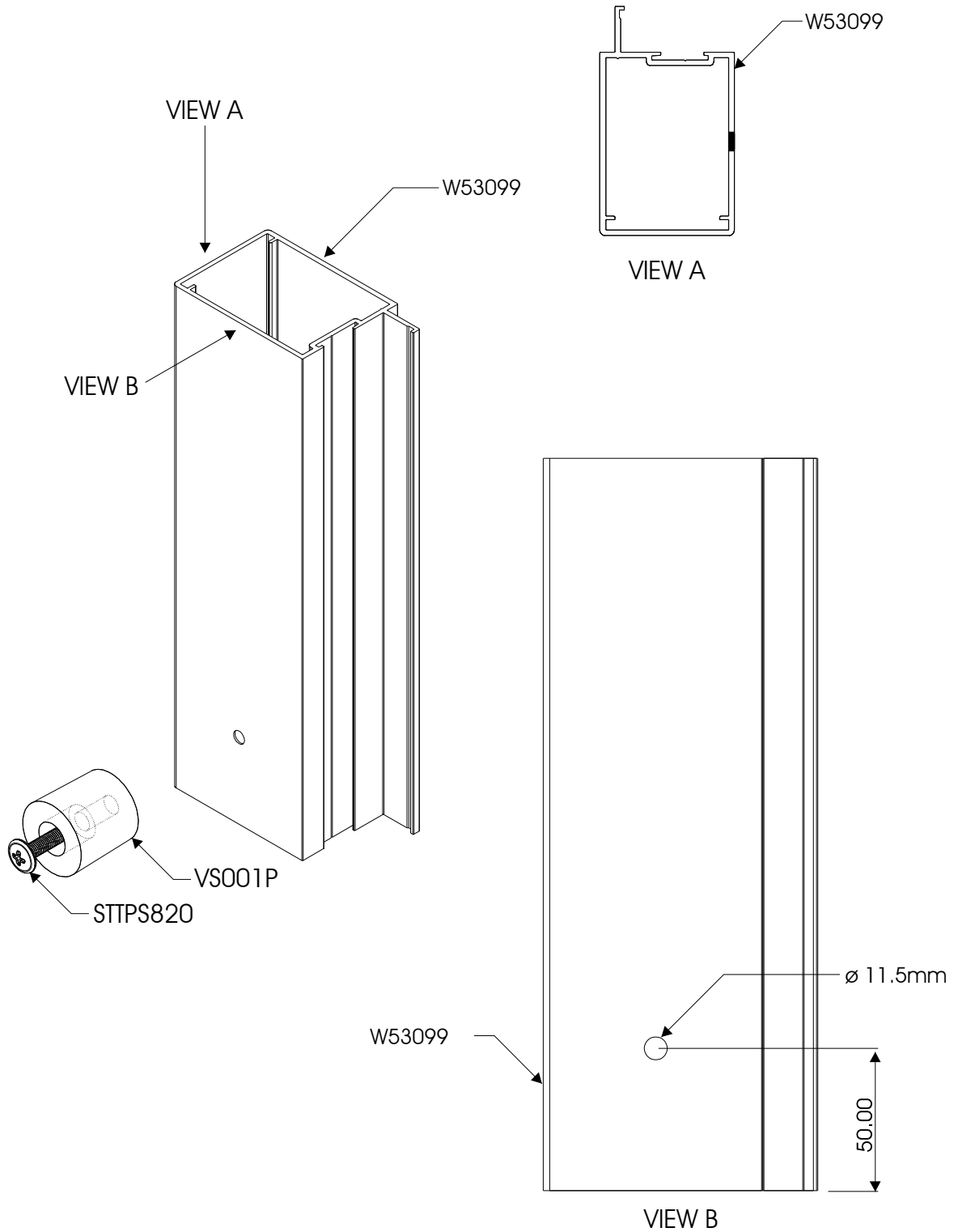

PALACE HIGH PERFORMANCE SLIDING DOOR AAAMSA TEST



TO PASS A1 WATER AND WIND TEST A ANTI-LIFT
WITH STICK ON WOOLPILE MUST BE SEALED IN ON
TOP OF FIXED PANEL AT INTERLOCK AND A 6MM
DRAINAGE HOLE AT FIXED DOORSTILE AT TOP

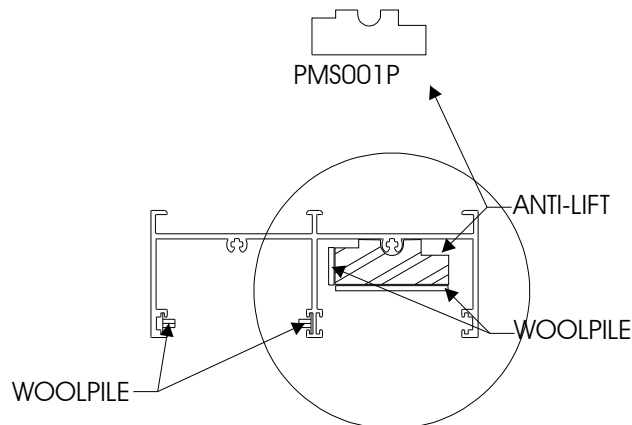
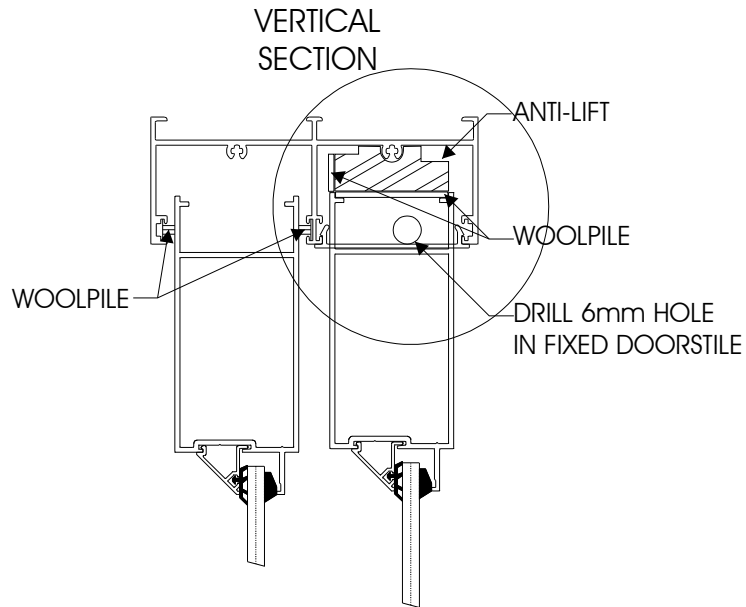

PALACE HIGH PERFORMANCE SLIDING DOOR SETTING BLOCK LOCATION



GLAZING

1. SELECTION OF GLAZING METHODS

1.1 SETTING AND LOCATION BLOCKS

Glass-to-metal contact must be avoided at all times by using setting and location blocks having a hardness of 50° to 90° shore A durometer. Use only blocks made of Neoprene, EPDM, Silicone or other elastomeric material.

Setting blocks are to have a minimum thickness of 3mm and must be at least 27mm in length per square metre of glass area.

The position of the setting and location blocks is illustrated in Figure 2.

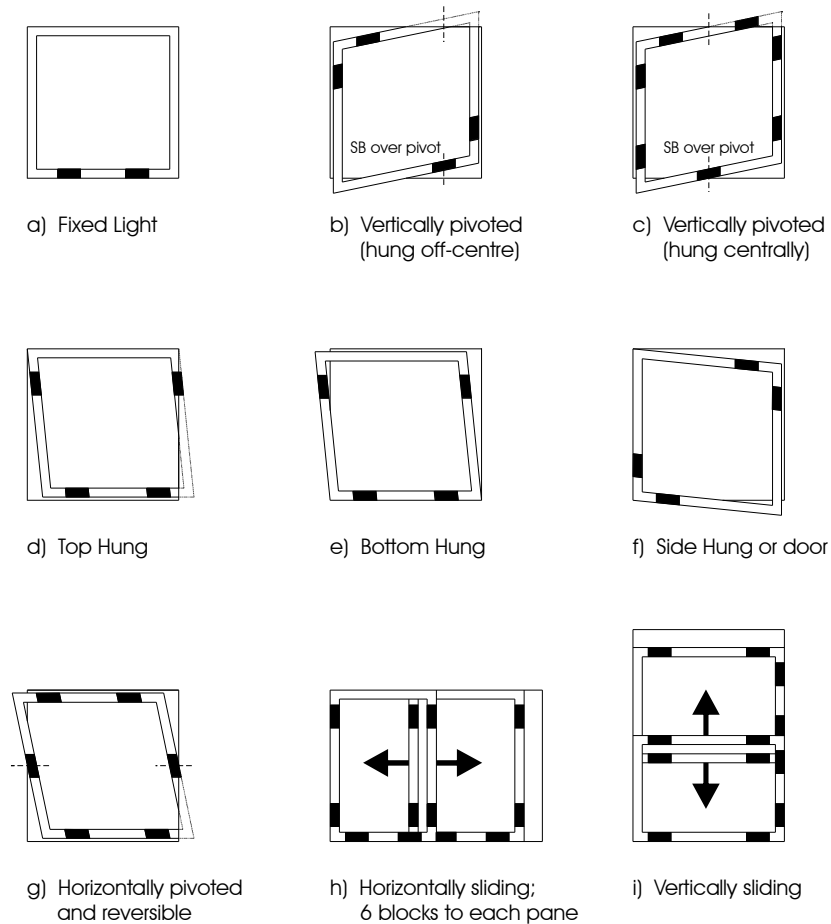

FIGURE 2 - POSITION OF SETTING AND LOCATION BLOCKS