



ROUGE

SQUARE CUT PATIO DOOR SYSTEM



DOUBLE TRACK

PRODUCT MANUAL
Revision 1.0

ROUGE DOUBLE TRACK

Index ii

Legal Disclaimer 1

Overview 2

General System

Profile Identification 3

 Double Track System Profiles 3

Hardware Components 5

Size Limitation Guide 6

Typical Configurations 6

Performance Configurations 7

 1000Pa Windload 7

 1500Pa Windload 8

 2000Pa Windload 9

 General Fixing Details 10

 Typical Cross-sectional Details 11

 Outer Frame Construction 14

 Outer Frame Machining Details 15

 Outer Frame Assembly Details 19

 Fixed Panel Construction 20

 Fixed Panel Machining Details 21

 Sliding Panel Construction 24

Meeting Stiles Option

Meeting Stiles Option 30

 Typical Cross-sectional detail 30

 Meeting Stile Female Machining details 31

 Meeting Stile Male Machining details 32

 Meeting Stile Overview 33

General Components

Installation 35

 Fixing Lug Details 35

 Door Installation Guide 36

 Rollers 37

ROUGE DOUBLE TRACK

General Documentation Disclaimer

This manual is intended as a manufacturing and installation advisory document. For correct specifications, sizing of profiles and structural information please consult the Starfront Application. If the information you require is not available through the Starfront Application, please contact a Wispeco Technical Representative before proceeding. It is advisable to have all sizing and performance criteria checked by a qualified structural engineer to ensure that all performance and compliance will be met.

All information, recommendations or advice contained in this documentation is given in good faith to the best of Wispeco's knowledge and is based on current procedures in effect.

Since the actual use of this documentation by the user is beyond the control of Wispeco, such use is within the exclusive responsibility of the user. Wispeco cannot be held responsible for any loss incurred through incorrect or faulty use of this documentation. Training of Wispeco systems is important for ensuring correct procedures in the manufacturing of products.

Great care has been taken to ensure that the information provided is correct.

Ensure that you have the latest available manual. The revision number and date can be checked on the latest Starfront version.

Wispeco will accept no responsibility for any errors and/or omissions, which may have inadvertently occurred.

This Guide may be reproduced in whole or in part in any form or by any means provided the reproduction or transmission acknowledges the origin, revision number and copyright date.

Specifications concerning products and applications

This manual is based on standard configurations only. As there are many configurations not covered in this manual, contact a Wispeco Technical Consultant with regard to a configuration not represented herein.

AutoDesk drawings (CAD Symbol Library) are available on request and can be issued with the consent of the Wispeco Technical Department.

All mechanical joints must be sealed with a Wispeco approved joint sealer. Failure to correctly seal the joints can affect the performance of the system. Information on joint sealing can be found in the Cleaning & Maintenance Manual available for download from the Wispeco website.

All drawings in the Wispeco Documentation are shown NOT to scale and are used for illustrative purposes only. For correct sizing and machining of system profiles refer to the Wispeco Starfront Application.

Wispeco cannot accept responsibility for the use of standard products since Wispeco does not know where these products are being installed.

The hardware recommended in this documentation is suitable for use in most atmospheric environments. When hardware is used in severe coastal environments the manufacturer of the hardware must be consulted.

The use of non-specified hardware or incorrect mechanical fasteners can adversely affect the mechanical and weathering performance of the system and we strongly advise against deviations. A Wispeco Consultant can advise you of any hardware issues and limitations with regard to this system.

The use of anti-magnetic stainless steel screws and aluminium pop rivets is recommended to reduce galvanic corrosion in harsh environments.

Fixing lugs on frames must be positioned as per the user manual and used in accordance to the AAAMSA specifications. When profiles are screwed together the screw centers must also be according to the user manual or as specified by an engineer.

All glass used within Wispeco products must comply with SAGGA regulations. Laminated glass must not stand in water.

By continuing to use this documentation you acknowledge that you understand and accept the legal disclaimer.

This manual must be read in conjunction with the Installation, Cleaning & Maintenance Document and the Performance Certificates for the relevant system. The manual must also be used in conjunction with the design and cutting list from the latest version of StarFront.

The Rouge Patio Door system has been designed to optimise the machining and manufacturing process while still delivering on aesthetics and performance. The system boasts a comprehensive range of interlockers with end caps (anti-lifts) for any configuration option, as well as a unique meeting stile configuration also with end caps.

The system's square-cut manufacturing and tubular profile design ensures maximum rigidity and accuracy, ensuring the longevity and consistency of the system.

The system is complimented by a full range of trim and hardware components, ensuring a aesthetically complete and high performance door.

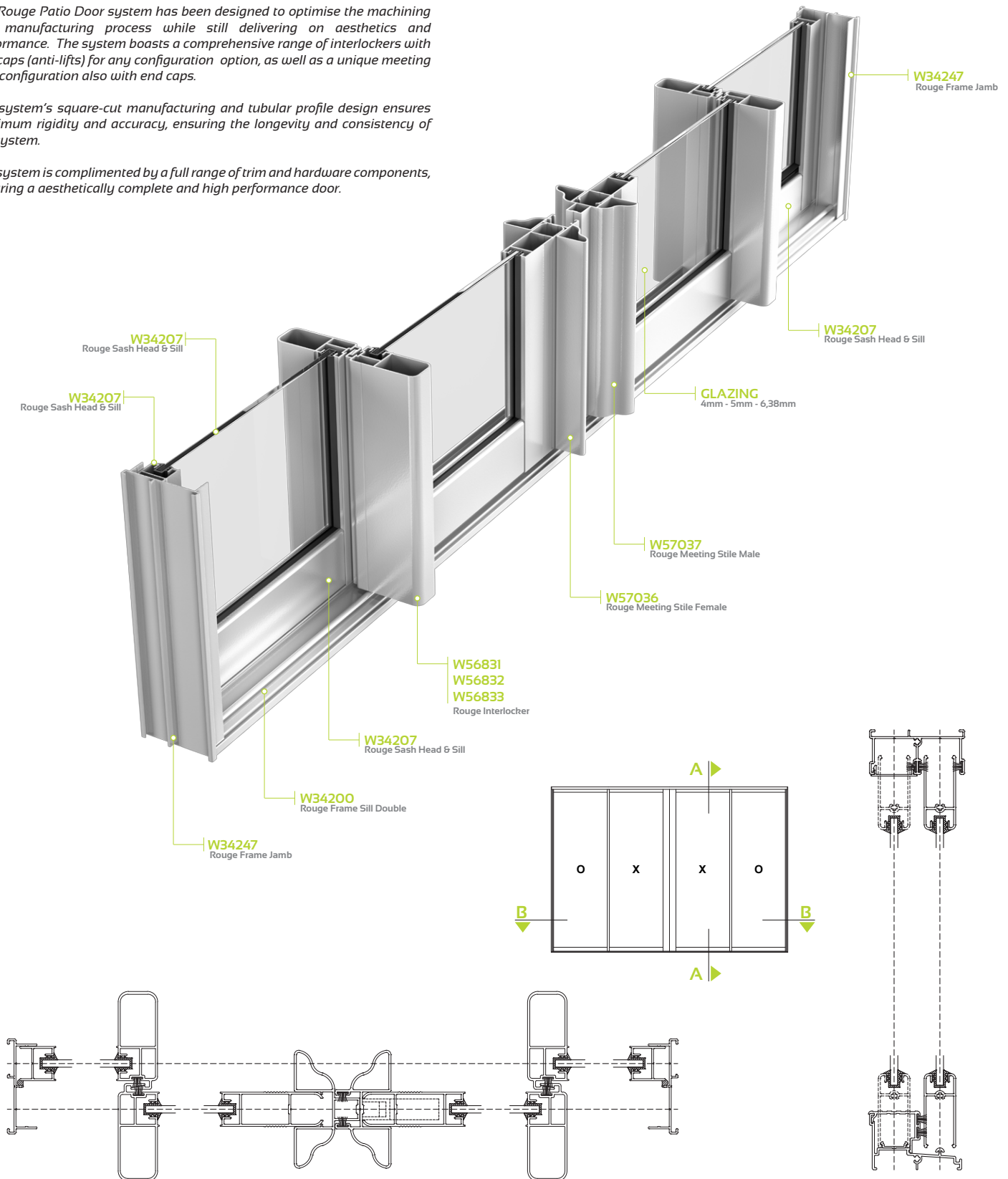

PROFILE IDENTIFICATION

DOUBLE TRACK SYSTEM PROFILES

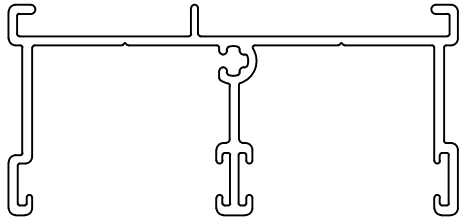

DIE No. W34206 Rouge Frame Head

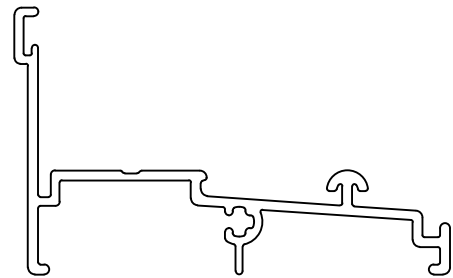

DIE No. W34200 Rouge Frame Sill Double

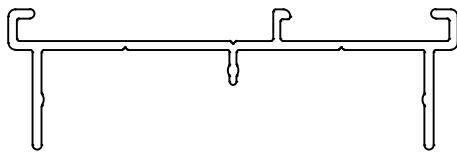

DIE No. W34247 Rouge Frame Jamb



DIE No. W34248 Rouge Jamb Cover

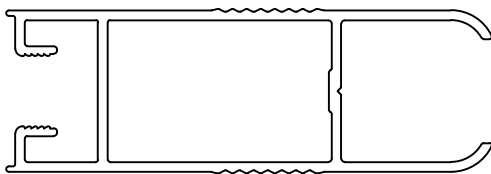

DIE No. W56834 Rouge Stile Lock

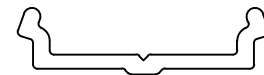

DIE No. W34201 Rouge Sill Fixed Panel Adapter

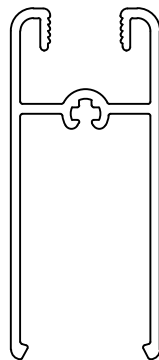

DIE No. W34207 Rouge Sash Head & Sill Rail



DIE No. W34204 Rouge Head Cover

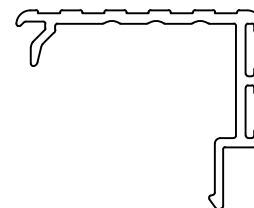

DIE No. W34208 Rouge Threshold Cover

PROFILE IDENTIFICATION

DOUBLE TRACK SYSTEM PROFILES

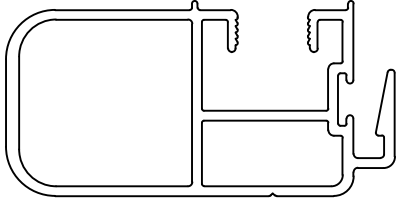

DIE No. W56831 Rouge Interlocker Standard

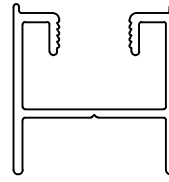

DIE No. W34205 Rouge Stile Fixed

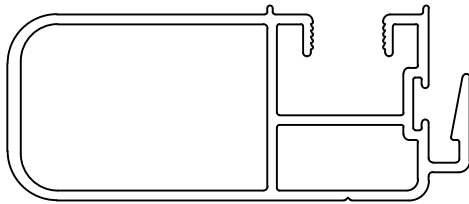

DIE No. W56832 Rouge Interlocker 60mm

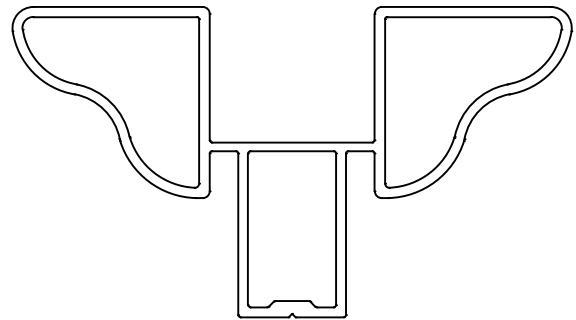

DIE No. W57037 Rouge Meeting Stile Male

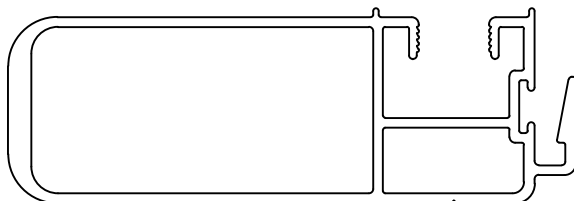

DIE No. W56833 Rouge Interlocker 75mm

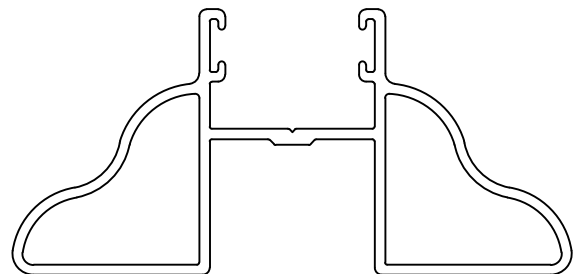

DIE No. W57036 Rouge Meeting Stile Female

HARDWARE COMPONENTS

RECOMMENDED ROUGE SLIDING DOOR COMPONENTS

All hardware is available through our Stockists as well as through Crealco Components, and can be viewed on www.crealco-components.com

LOCK & HANDLE

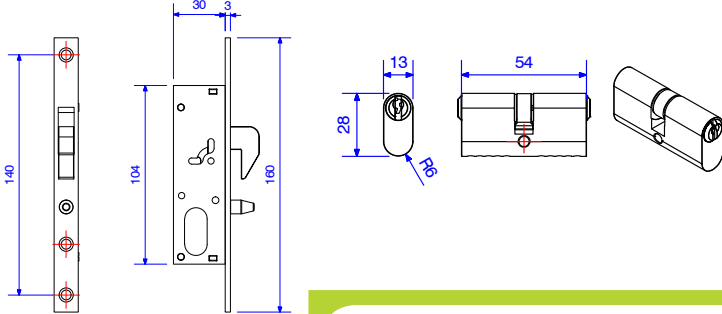

IS769201/20

Hooklock

PDK700M

Patio Door Keep Kit

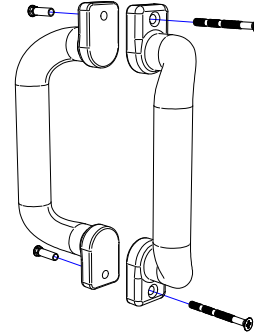

HNDROUGE

Universal Regal Handle

FASTNERS

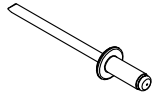

CSKR4810

4.8 x 10 Pop Rivet

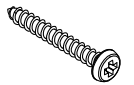

STPP5830

Screw 8 x 30



GRMT

9mm Grommets

Escutcons

END CAPS

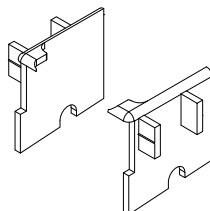

Triple Track Threshold End Cap
Left Hand & Right Hand

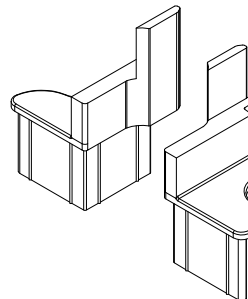

Meeting Stile End Caps
Internal & External

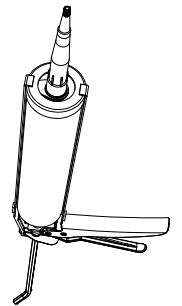

Silicone

ROLLERS

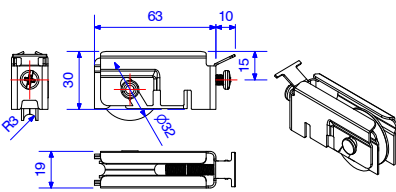

ROLL650FG

Patio Door Roller S/S

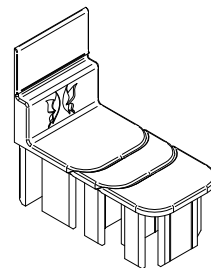

Universal Interlocker End Cap

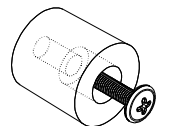

V500IP-STPPB20

Stopper with Screw

GASKETS & FINSEAL

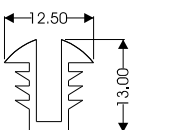

JCI5005

Channel H33
4mm Glass

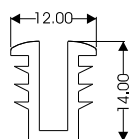

JCI5004FG

Channel H21
5mm Glass

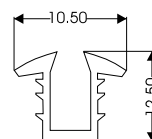

GC6F6

Channel H19
6.38mm Glass



FP67900300FG

Finseal

SIZE LIMITATION GUIDE

The size limitations of the system are strictly calculated in accordance to AAAMSA guidelines and take into account the aluminium specifications as well as the glass used. Please ensure that these are adhered to as any product produced outside of these limitations will not adhere to AAAMSA regulations.

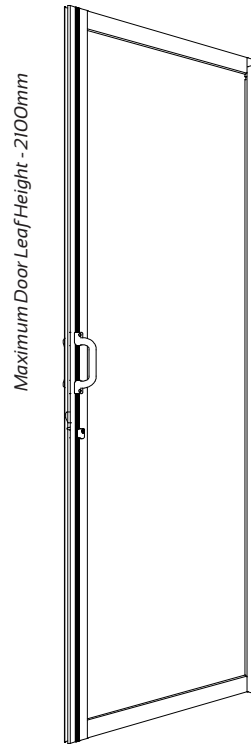
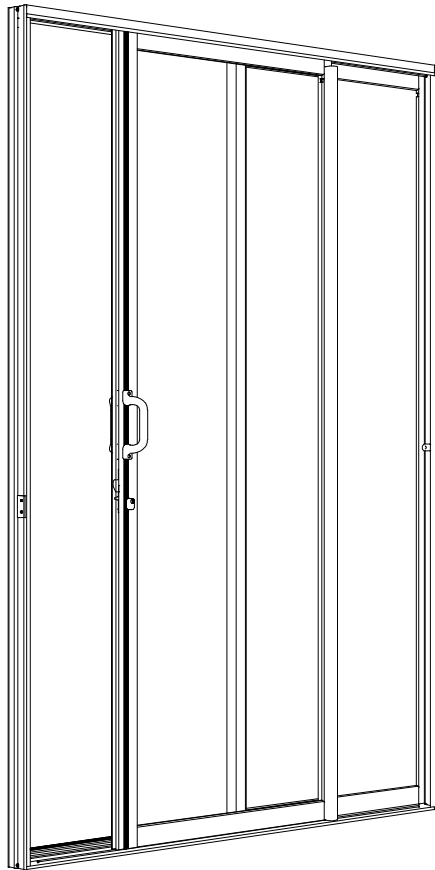

Maximum Door Leaf Height - 2100mm

Maximum Door Leaf Width - 1500mm

TYPICAL CONFIGURATIONS

Below are the most popular system configuration used within South Africa. For insect Screen configurations see *Insect Screen Manual* and *Typical Details* on Page 38

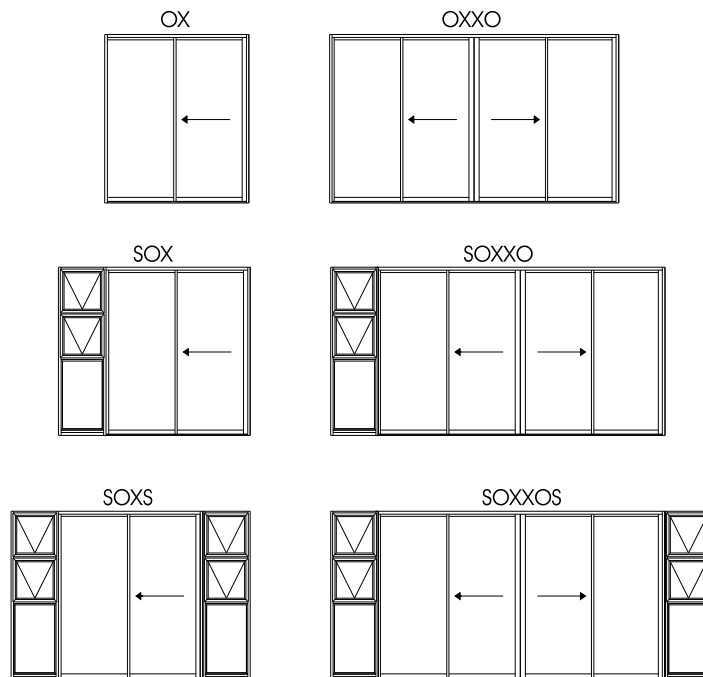

This manual must be read in conjunction with the Installation, Cleaning & Maintenance Document and the Performance Certificates for the relevant system. The manual must also be used in conjunction with the design and cutting list from the latest version of StarFront.

Disclaimer: The right to make alterations is reserved
© 2013 Wispeco (Pty) Ltd, All Rights Reserved

PERFORMANCE CONFIGURATIONS

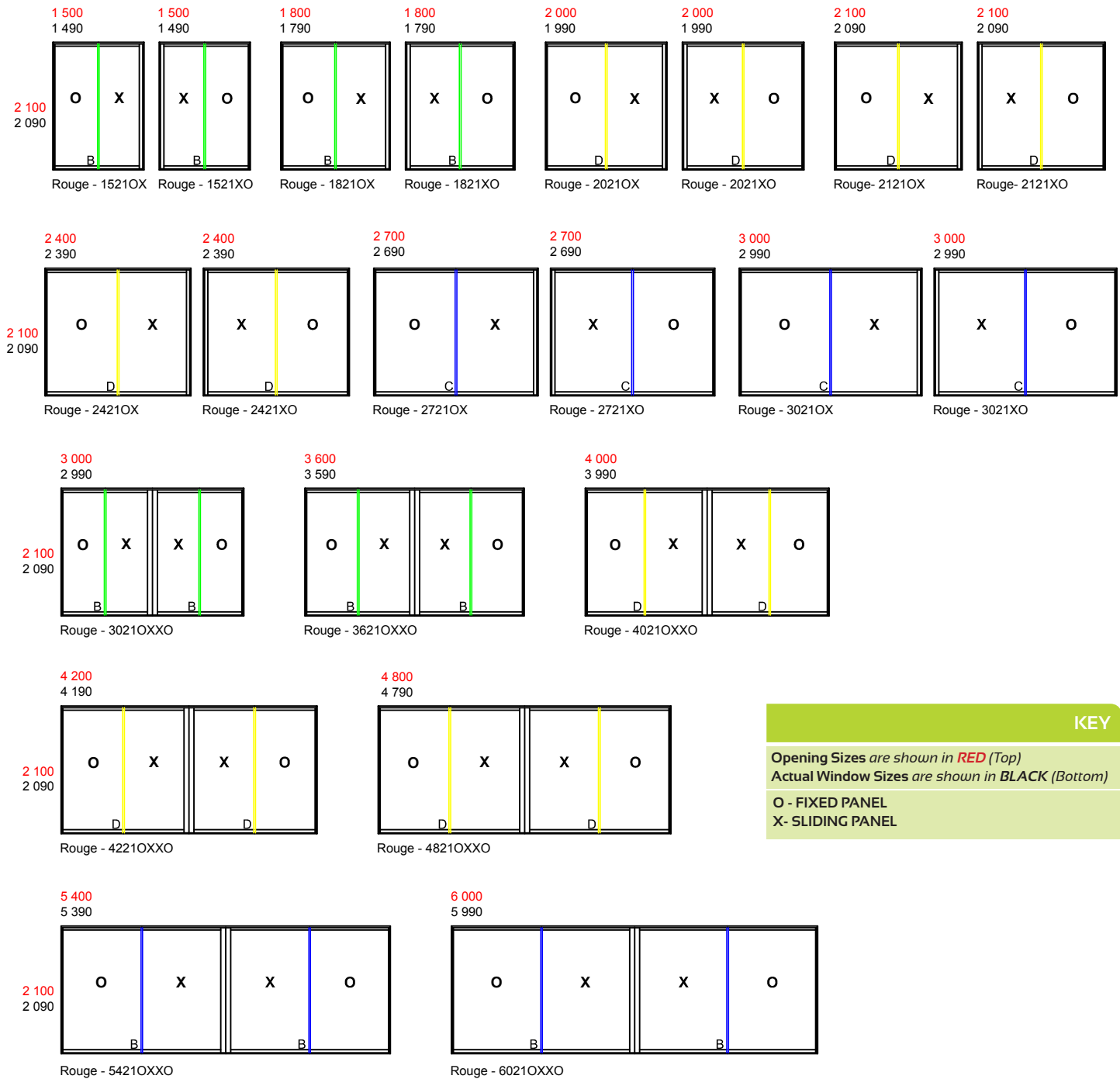

KEY

Opening Sizes are shown in **RED** (Top)
Actual Window Sizes are shown in **BLACK** (Bottom)

O - FIXED PANEL
X - SLIDING PANEL

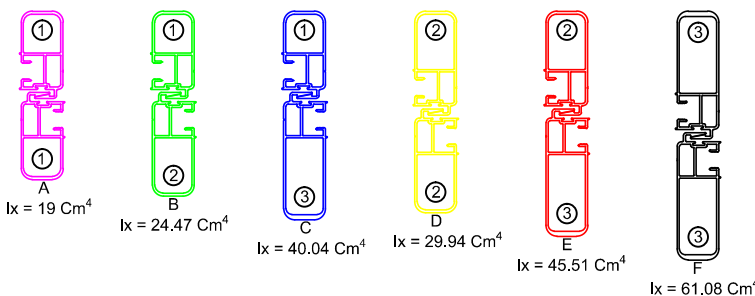

- 1. Interlocker Standard - 49.5mm
- 2. Interlocker 60mm
- 3. Interlocker 75mm

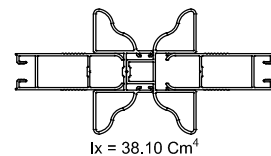

INTERLOCKERS

MEETING STILES

PERFORMANCE CONFIGURATIONS

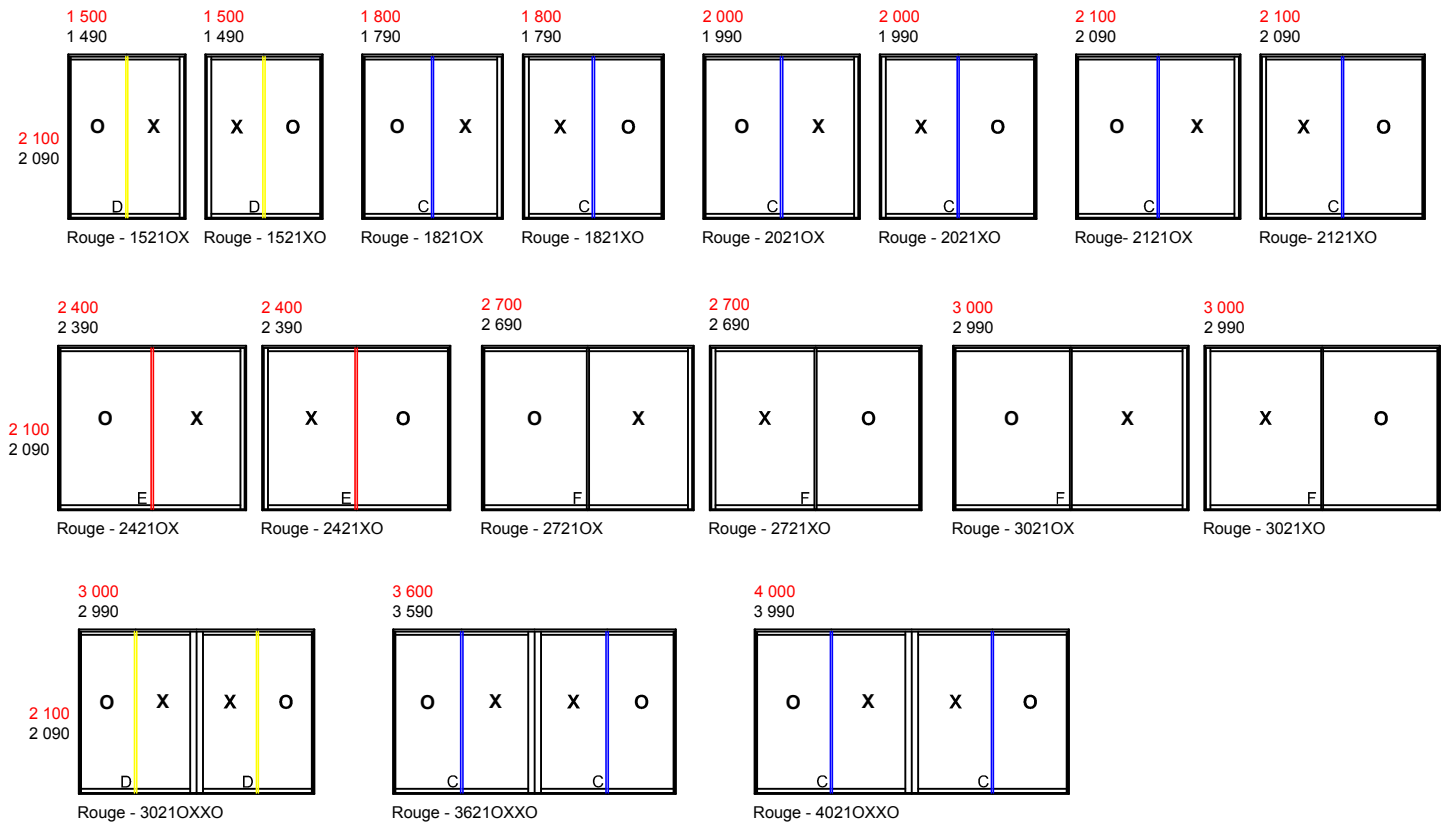

KEY

Opening Sizes are shown in **RED** (Top)
Actual Window Sizes are shown in **BLACK** (Bottom)

O - FIXED PANEL
X - SLIDING PANEL

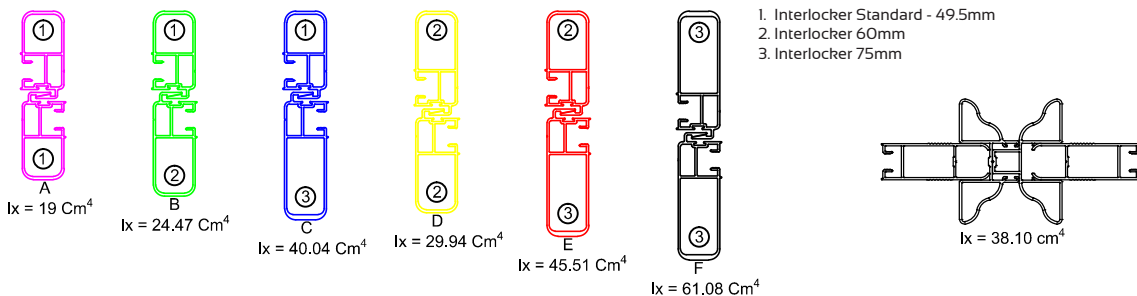

INTERLOCKERS

MEETING STILES

PERFORMANCE CONFIGURATIONS

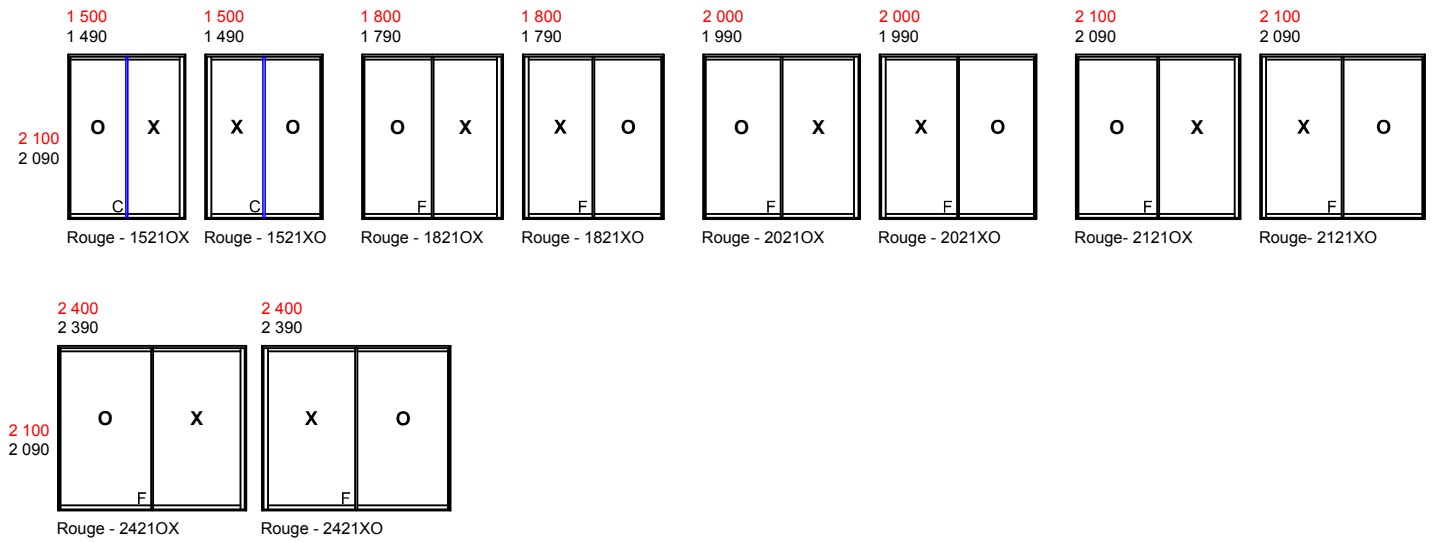

KEY

Opening Sizes are shown in **RED** (Top)
Actual Window Sizes are shown in **BLACK** (Bottom)

O - FIXED PANEL
X - SLIDING PANEL

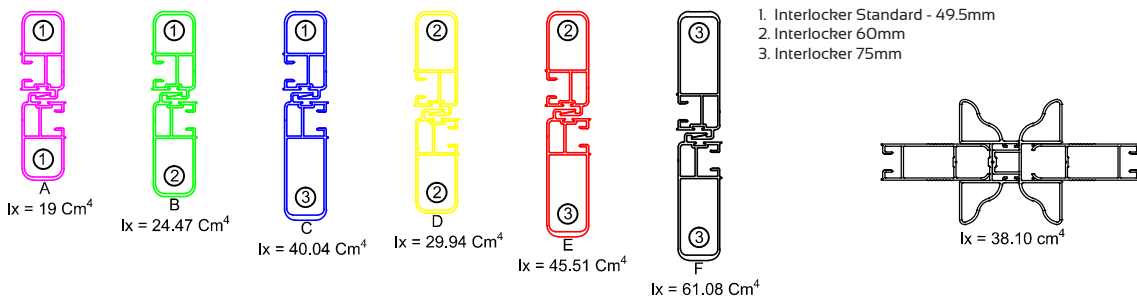

INTERLOCKERS

MEETING STILES

This manual must be read in conjunction with the Installation, Cleaning & Maintenance Document and the Performance Certificates for the relevant system. The manual must also be used in conjunction with the design and cutting list from the latest version of StarFront.

*Disclaimer: The right to make alterations is reserved
© 2013 Wispeco (Pty) Ltd, All Rights Reserved*

IMPORTANT: As there are many different methods of fixing the door to the structure, the illustration below is a general fixation detail. The illustration defines the general method and hole fixings. Before installation or machining of the holes, please ensure that you have checked the required fixing method with the appropriated building engineer and that your chosen methods meets their specifications.

Failure to fix the door to correct building or engineer specifications will result in the door not meeting the required specifications.

DISCLAIMER: Please note that fixation of the frame to the structure is an element which **MUST** be specified and certified by an appropriate engineer and is not the responsibility of Wispeco.

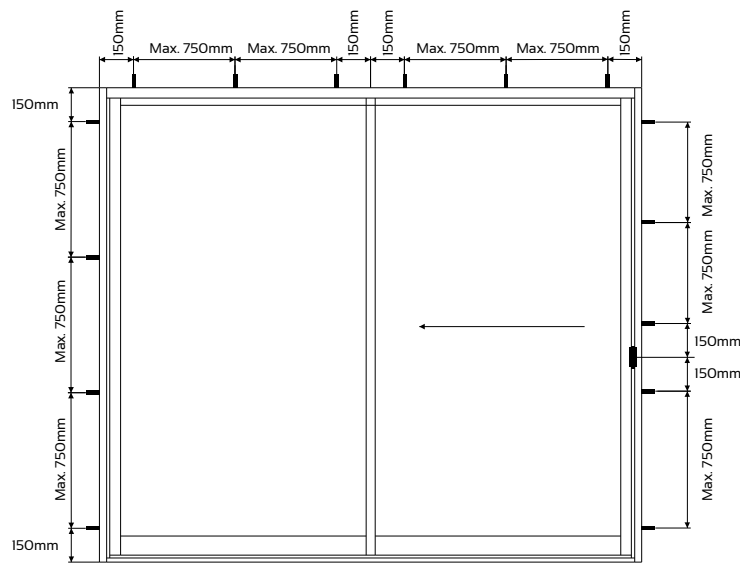

Typical OX Sliding Door

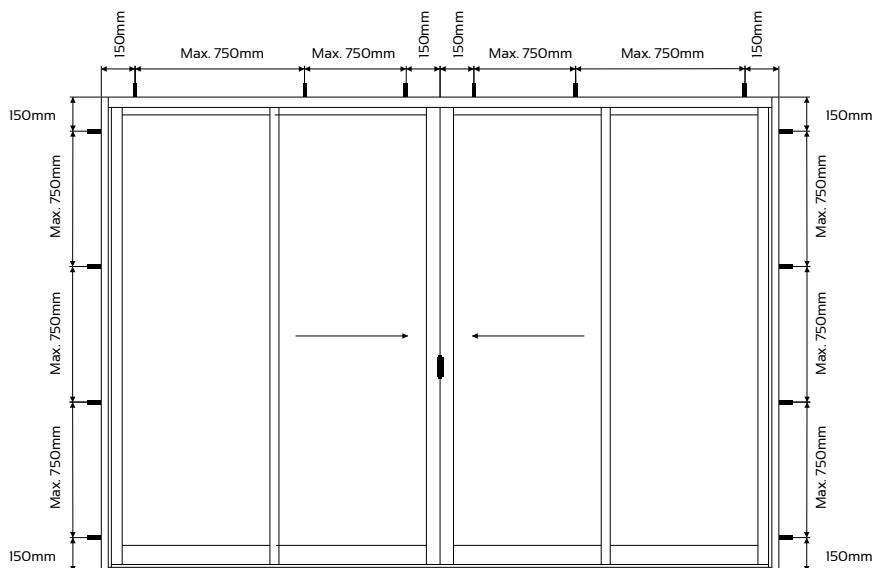

Typical OXXO Sliding Door

NOTE: Sill (bottom track) to be fixed to floor with a non-shrinking grout.

This manual must be read in conjunction with the Installation, Cleaning & Maintenance Document and the Performance Certificates for the relevant system. The manual must also be used in conjunction with the design and cutting list from the latest version of StarFront.

*Disclaimer: The right to make alterations is reserved
© 2013 Wispeco (Pty) Ltd, All Rights Reserved*

DOUBLE TRACK MANUAL

TYPICAL CROSS-SECTIONAL DETAILS
OX CONFIGURATION

Standard Interlocker 49.5mm

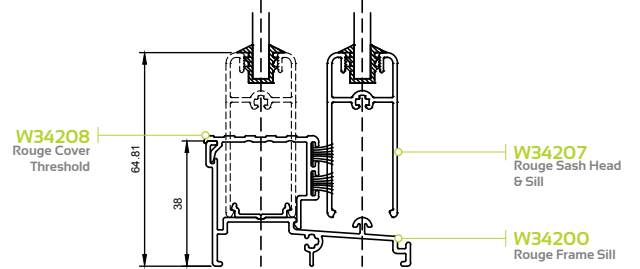
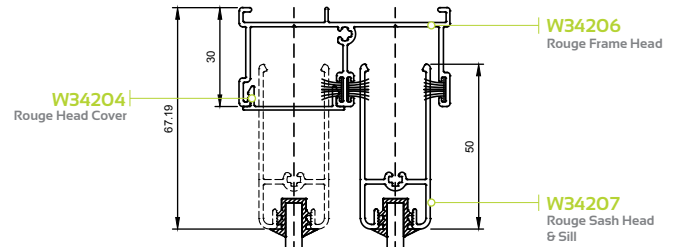
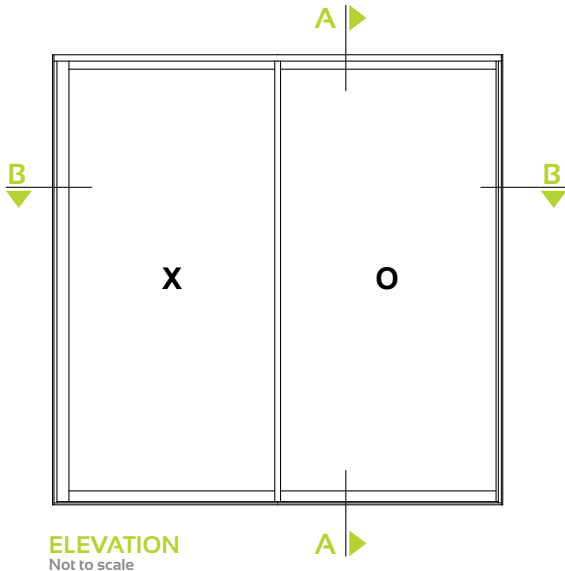

SECTION A-A
Section not to scale

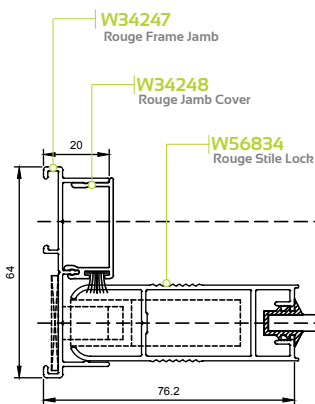

SECTION B-B
Section not to scale

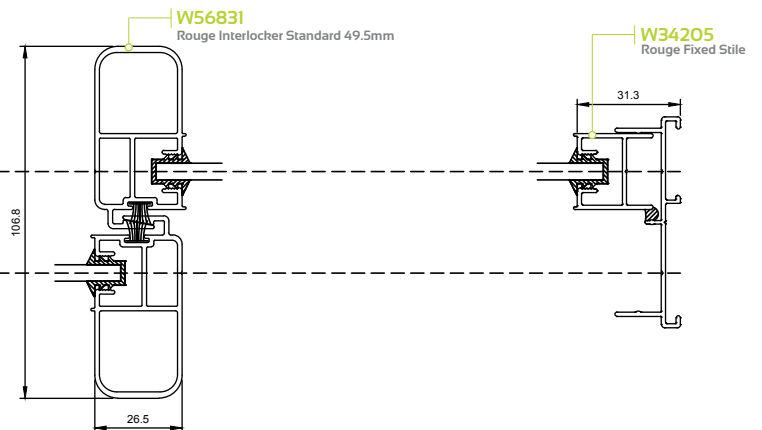

DOUBLE TRACK MANUAL

TYPICAL CROSS-SECTIONAL DETAIL
OX CONFIGURATION

60mm Interlocker

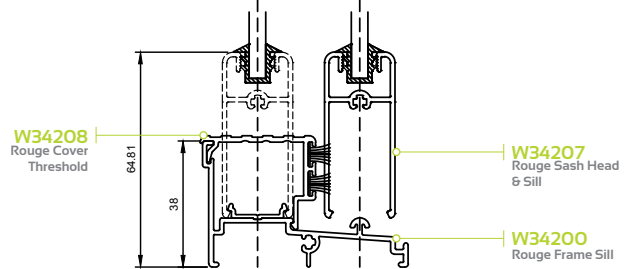
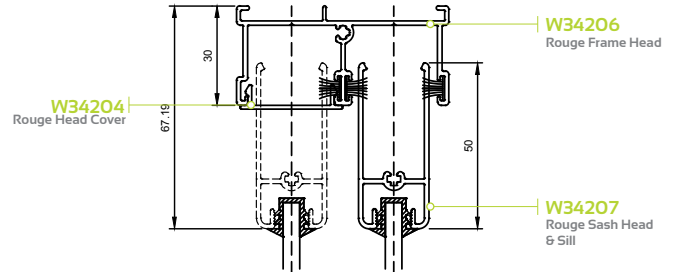
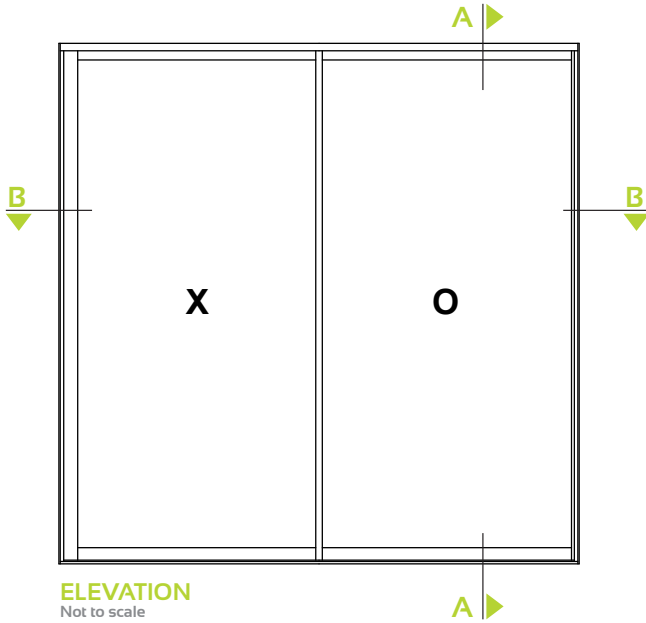

SECTION A-A
Section not to scale

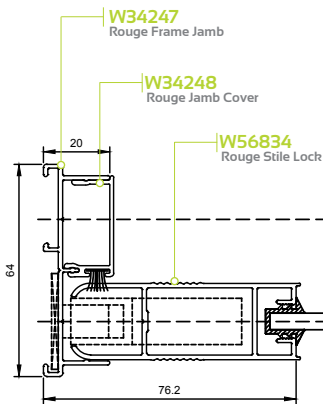

SECTION B-B
Section not to scale

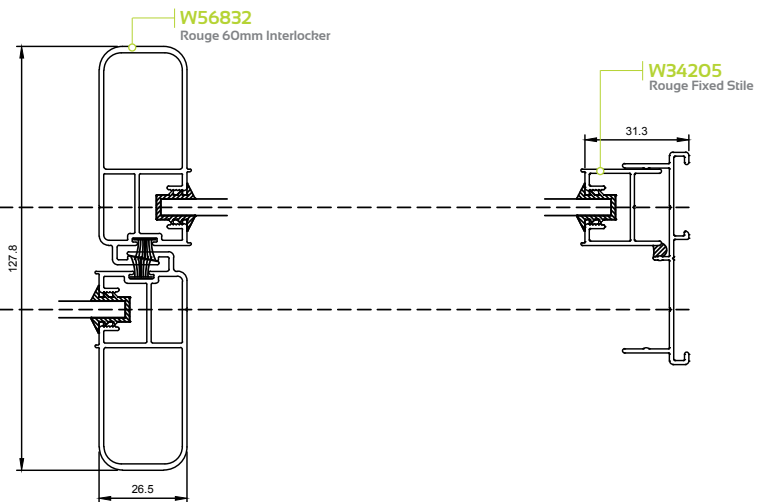

DOUBLE TRACK MANUAL

**TYPICAL CROSS-SECTIONAL DETAIL
OX CONFIGURATION**

75mm Interlocker

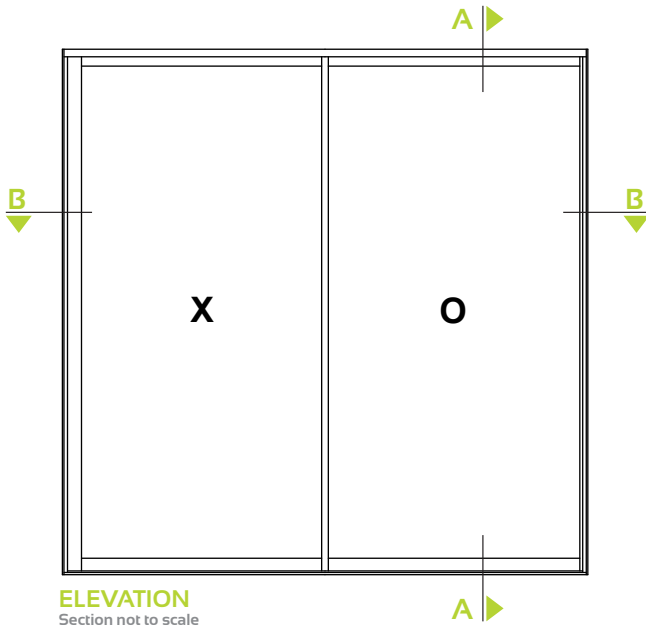

ELEVATION
Section not to scale

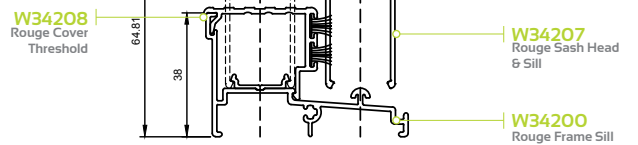
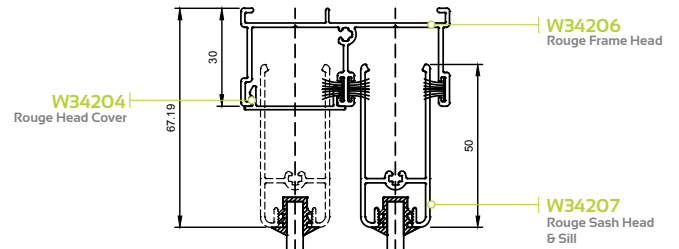

SECTION A-A
Section not to scale

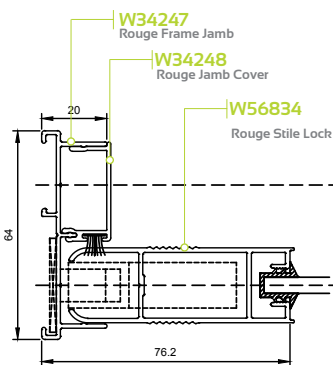

SECTION B-B
Section not to scale

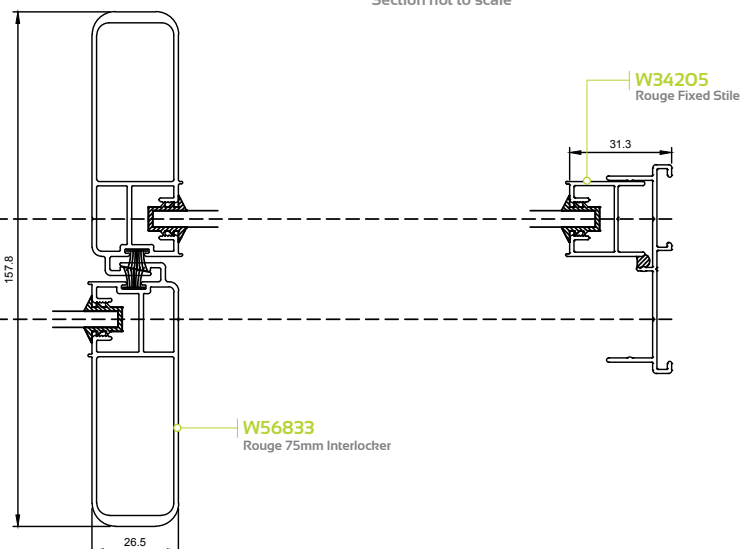

This manual must be read in conjunction with the Installation, Cleaning & Maintenance Document and the Performance Certificates for the relevant system. The manual must also be used in conjunction with the design and cutting list from the latest version of StarFront.

*Disclaimer: The right to make alterations is reserved
© 2013 Wispeco (Pty) Ltd, All Rights Reserved*

DOUBLE TRACK MANUAL

**OUTER FRAME CONSTRUCTION
TYPICAL CONFIGURATION**

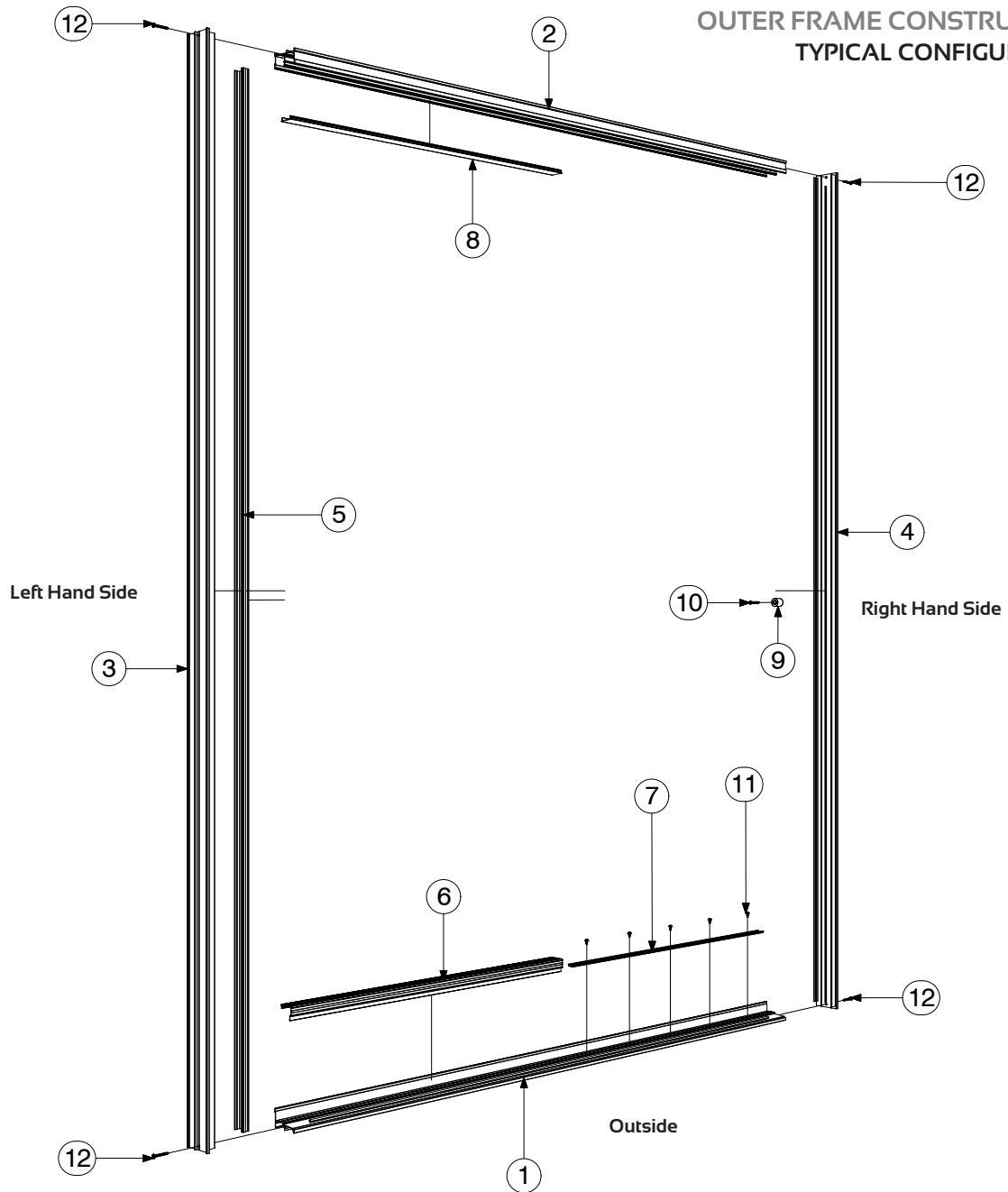

System Profiles

ITEM	QTY	DIE No.	DESCRIPTION	MACHINING
1	1	W34200	Rouge Frame Sill Double	✓
2	1	W34206	Rouge Frame Head	✗
3	1	W34247	Rouge Frame Jamb LHS	✓
4	1	W34247	Rouge Frame Jamb RHS	✓
5	1	W34248	Rouge Jamb Cover	✗
6	1	W34208	Rouge Threshold Cover	✗
7	1	W34201	Rouge Sill Adapter	✗
8	1	W34204	Rouge Cover Head	✗

Hardware

ITEM	QTY	COMPONENT	DESCRIPTION
9	1	Stopper	Rubber Stopper
10	1	Screw no8 x 30	Rubber Stopper Screw
11	5	Screw no8 x 9.5	(Can be replaced with pop rivets)
12	4	Screw no8 x 30	Frame Screws

OUTER FRAME MACHINING DETAILS

Please note: These details pertain to the machining of profiles. Lengths of profiles and cutting lists need to be confirmed using the Startfont program to ensure compliance to the SANS Building regulations.

DIE No. 34200 Rouge Frame Sill Double

Section not to scale

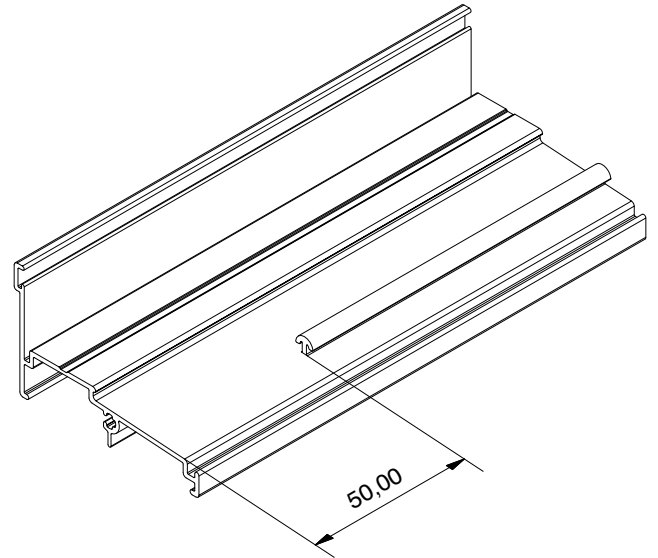
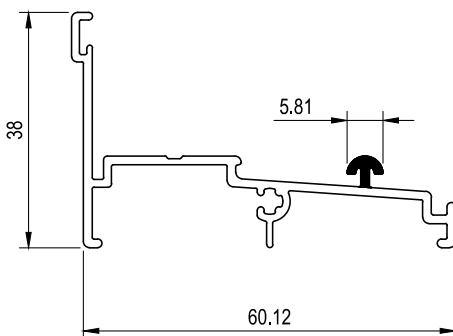
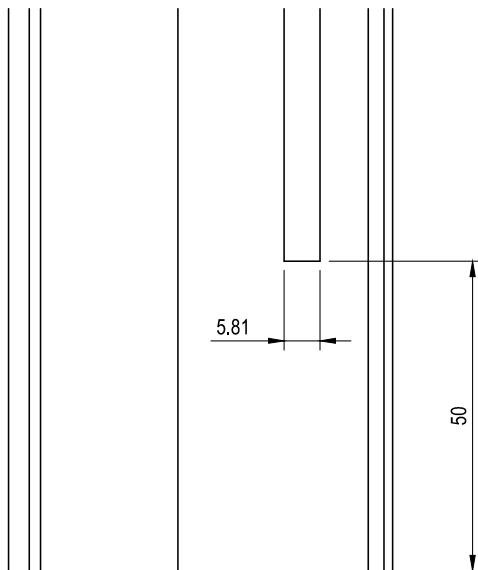
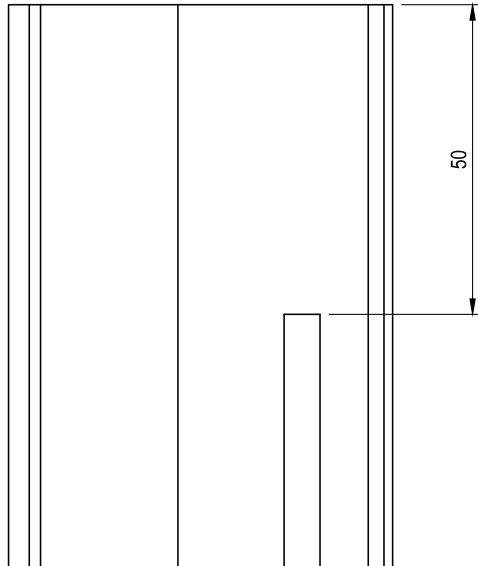

Sill Track Machining.

Note: The only machining required for this profile is the track as shown.

Machining of the track allows for correct weathering of the system, allowing water to effectively drain from the track area. Any other modification to the sill may affect the correct operation and performance of the track.

OUTER FRAME MACHINING DETAILS

Please note: These details pertain to the machining of profiles. Lengths of profiles and cutting lists need to be confirmed using the Startfont program to ensure compliance to the SANS Building regulations.

DIE No. 34201

Rouge Sill Fixed Panel Adapter

Section not to scale

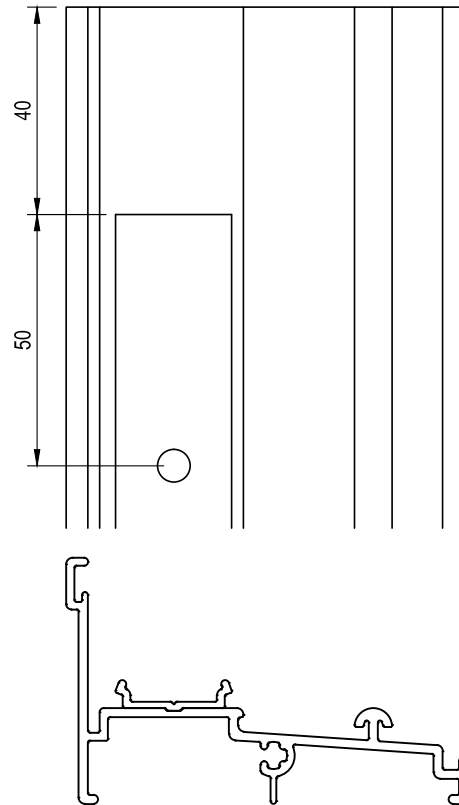
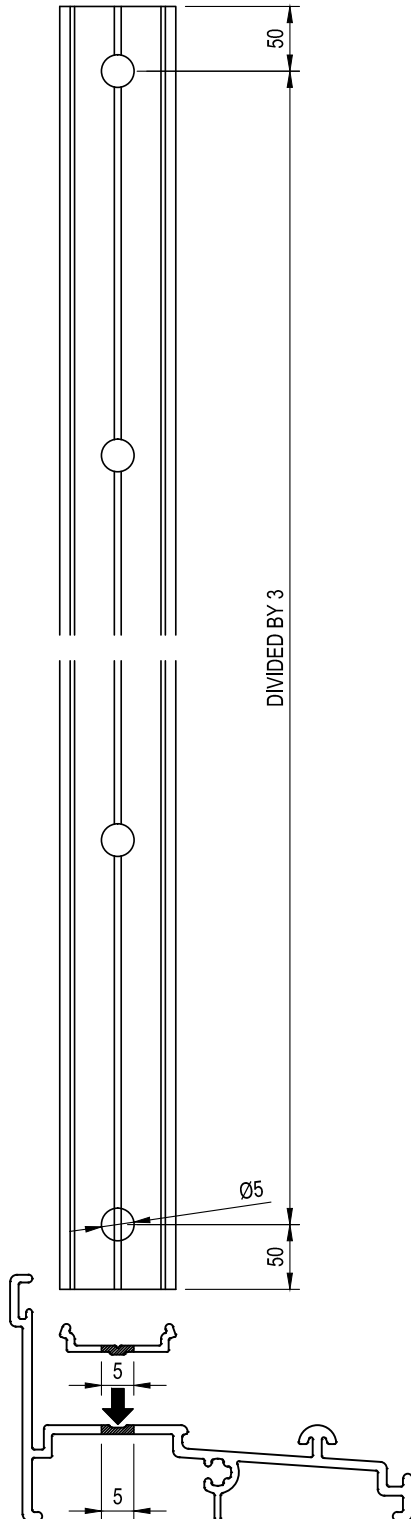

Note: Ensure that the Holes and fixation method of the Sill Adapter do not interfere with the Outer Frame Fixation Holes and method.

The Sill Adapter must be fixed correctly to the Sill and not the building structure. Do not fix the Sill adapter to the building structure as it may loosen over time.

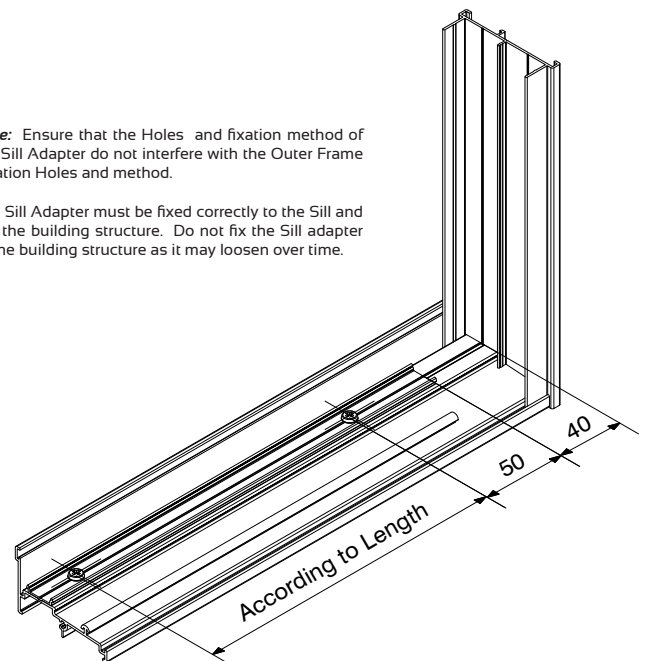

OUTER FRAME MACHINING DETAILS

Please note: These details pertain to the machining of profiles. Lengths of profiles and cutting lists need to be confirmed using the Startfont program to ensure compliance to the SANS Building regulations.

DIE No. 34247

Rouge Frame Jamb

Section not to scale

Jamb Machining:

There are two machining requirements on the jamb:

1. General Jamb to Head and Sill location and fixing
2. Lock Keep machining.

Note: Pay close attention to LHS and RHS Machining. Ensure that the correct machining is done on the correct side. Inverted machining will still correctly fix to the head and Sill but will affect the integrity of the door.

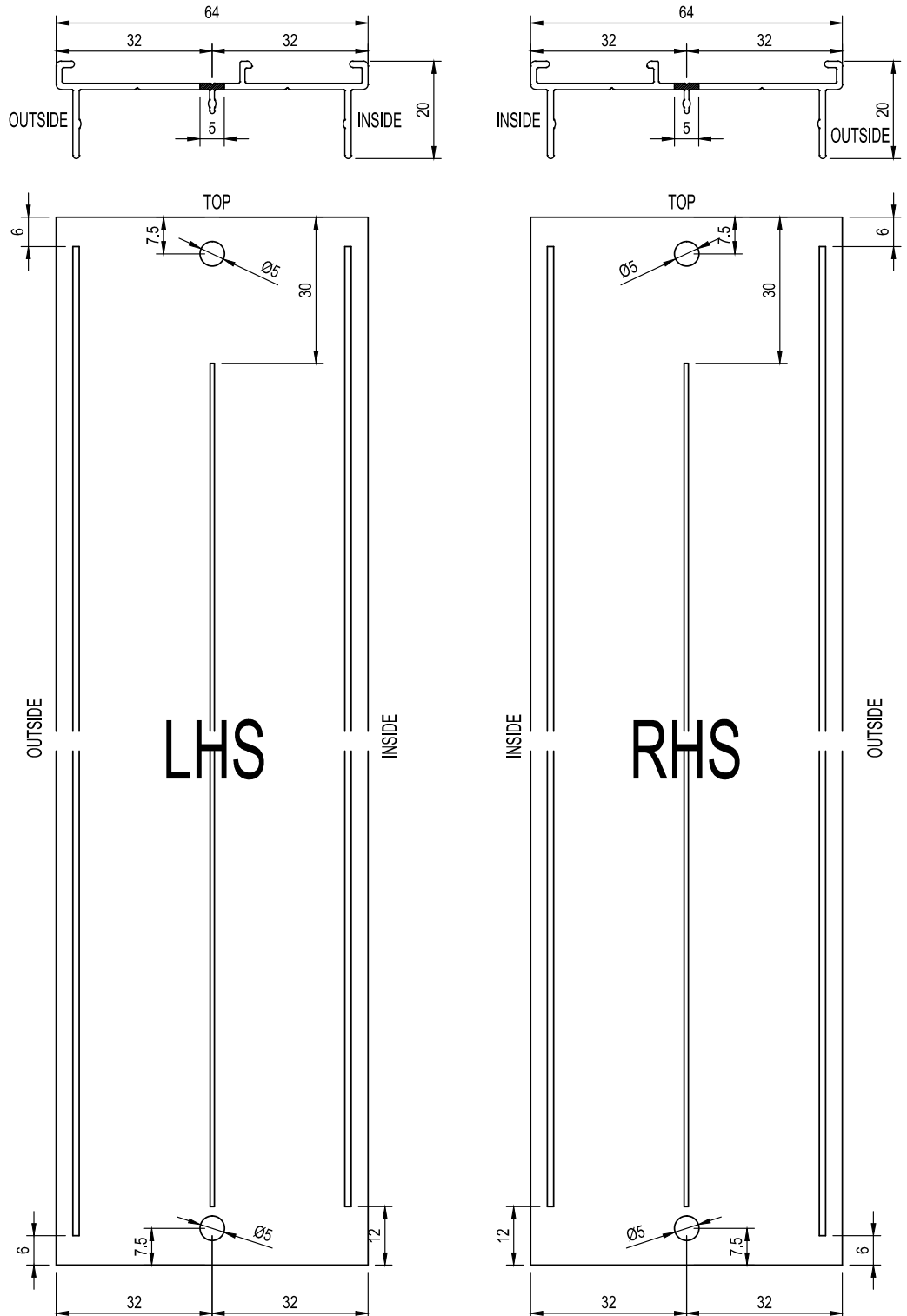

This manual must be read in conjunction with the Installation, Cleaning & Maintenance Document and the Performance Certificates for the relevant system. The manual must also be used in conjunction with the design and cutting list from the latest version of StarFront.

Disclaimer: The right to make alterations is reserved
© 2013 Wispeco (Pty) Ltd, All Rights Reserved

OUTER FRAME MACHINING DETAILS

Please note: These details pertain to the machining of profiles. Lengths of profiles and cutting lists need to be confirmed using the Startfont program to ensure compliance to the SANS Building regulations.

DIE No. 34247

Rouge Frame Jamb

Section not to scale

Jamb Lock Keep Machining:

Ensure that the lock keep machining matches the calculations used on the Lock Machining and that both the lock and the lock keep line up.

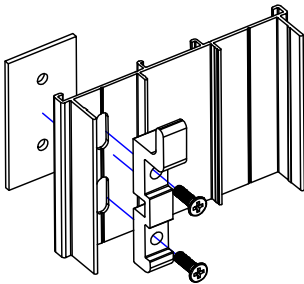

Jamb Lock Keep Adjustment:

The slotted holes ensure simple adjustment of the lock keep prior and post installation of the door to ensure that the lock keep remains adjustable. This will assist in alignment of the lock when the rollers and the door height requires adjustment.

Wet trades:

When the door is fixed to the building, ensure that plaster or other building materials do not affect the lock keep adjustments.

Anti-Lift Lock:

The Locking assembly also acts as the anti-lift for the sliding panel. Please ensure that the mechanism is aligned properly to ensure proper engagement.

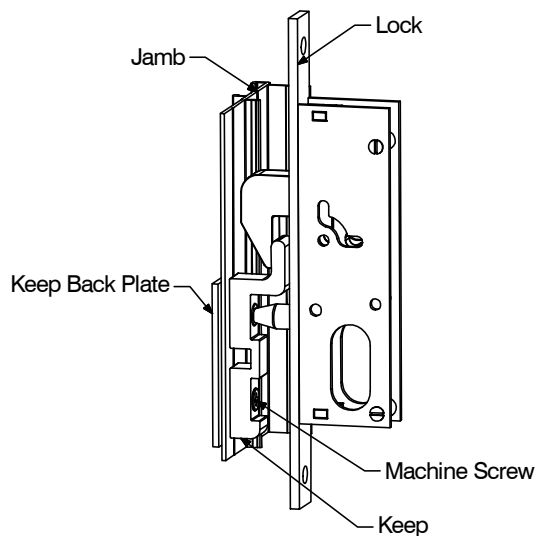
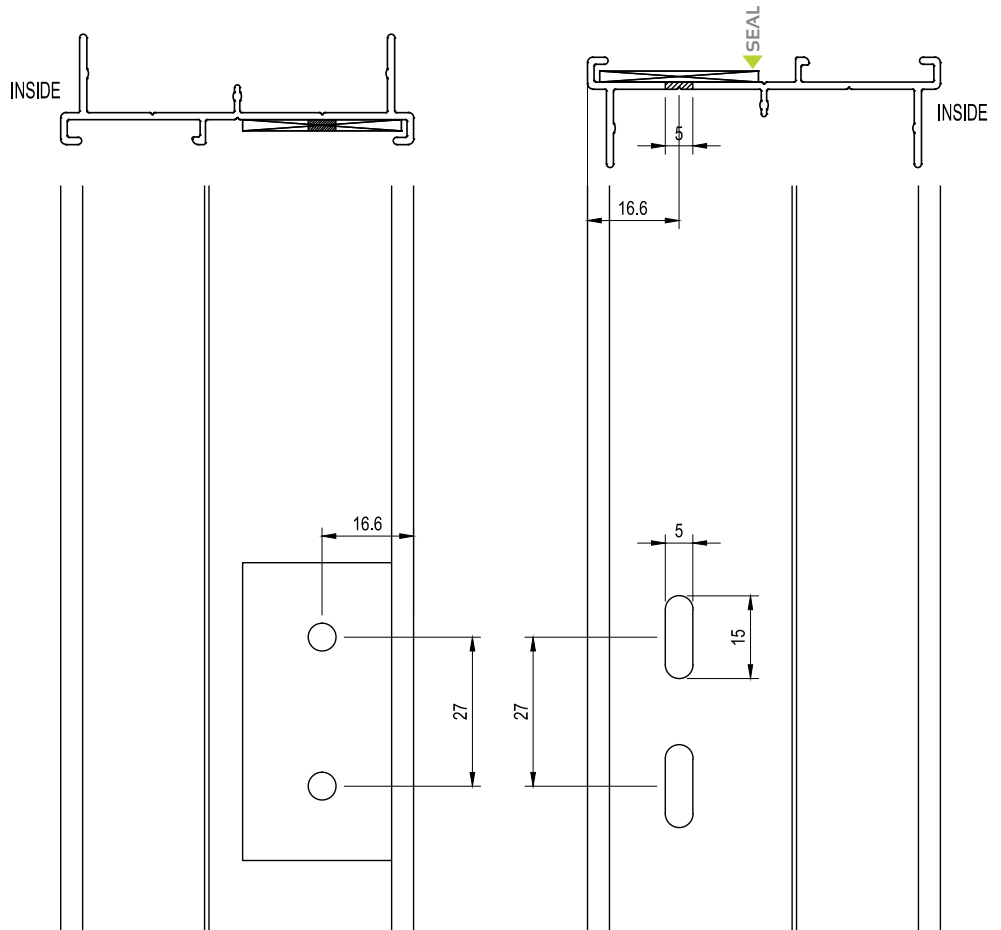

This manual must be read in conjunction with the Installation, Cleaning & Maintenance Document and the Performance Certificates for the relevant system. The manual must also be used in conjunction with the design and cutting list from the latest version of StarFront.

*Disclaimer: The right to make alterations is reserved
© 2013 Wispeco (Pty) Ltd, All Rights Reserved*

OUTER FRAME ASSEMBLY DETAILS

Please note: These details pertain to the machining of profiles. Lengths of profiles and cutting lists need to be confirmed using the Startfont program to ensure compliance to the SANS Building regulations.

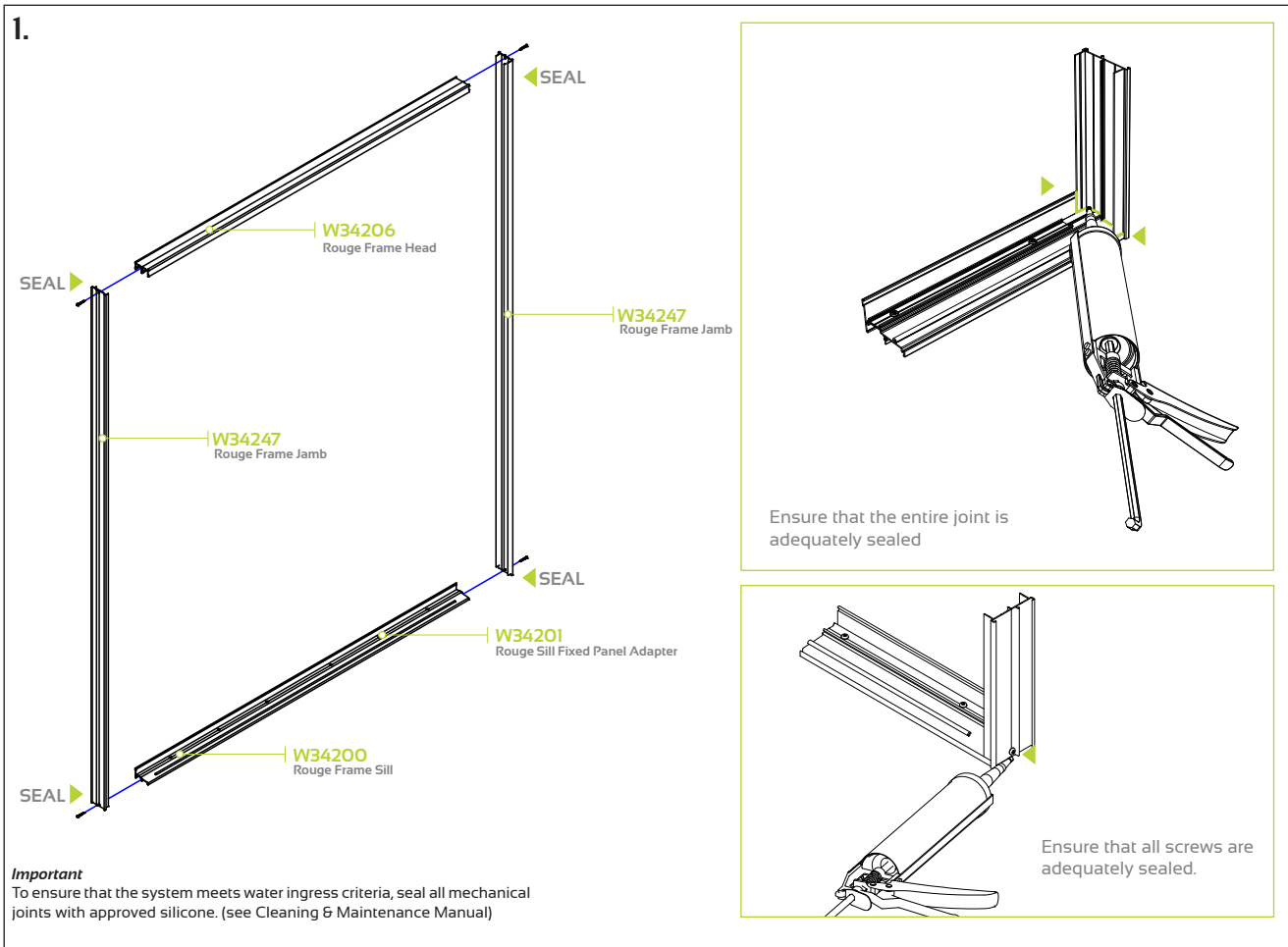

1. Outer Frame Assembly

Affix the Jamb to the head and Sill rails using the 8 x 30 screws.

Ensure that the Finpile is inserted prior to installation.

2. Fixed Panel Sill Adapter

Install the fixed panel Sill adapter once the outer frame has been affixed to the structure / void.

3. Install Outer Frame

Install the outer frame into the structure or void using preferred method. (see Fixing Details for correct fixation dimensions)

4. Jamb Cover

Important: Insert the Jamb cover into the lock jamb before inserting the head and threshold covers. Ensure that the Finpile is inserted prior to installation.

5. Sill Threshold

It is advisable to clip the Sill threshold into place AFTER the installation of the fixed panel. Ensure that the Finpile is inserted prior to installation.

6. Head Cover

It is advisable to clip the head cover into place AFTER the installation of the fixed panel.

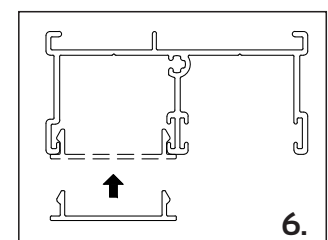
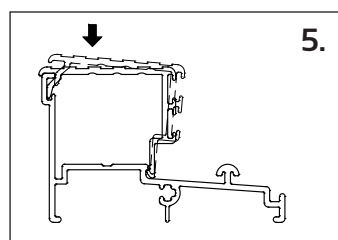
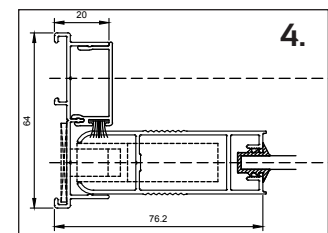
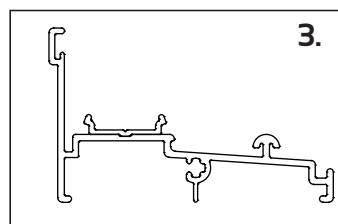

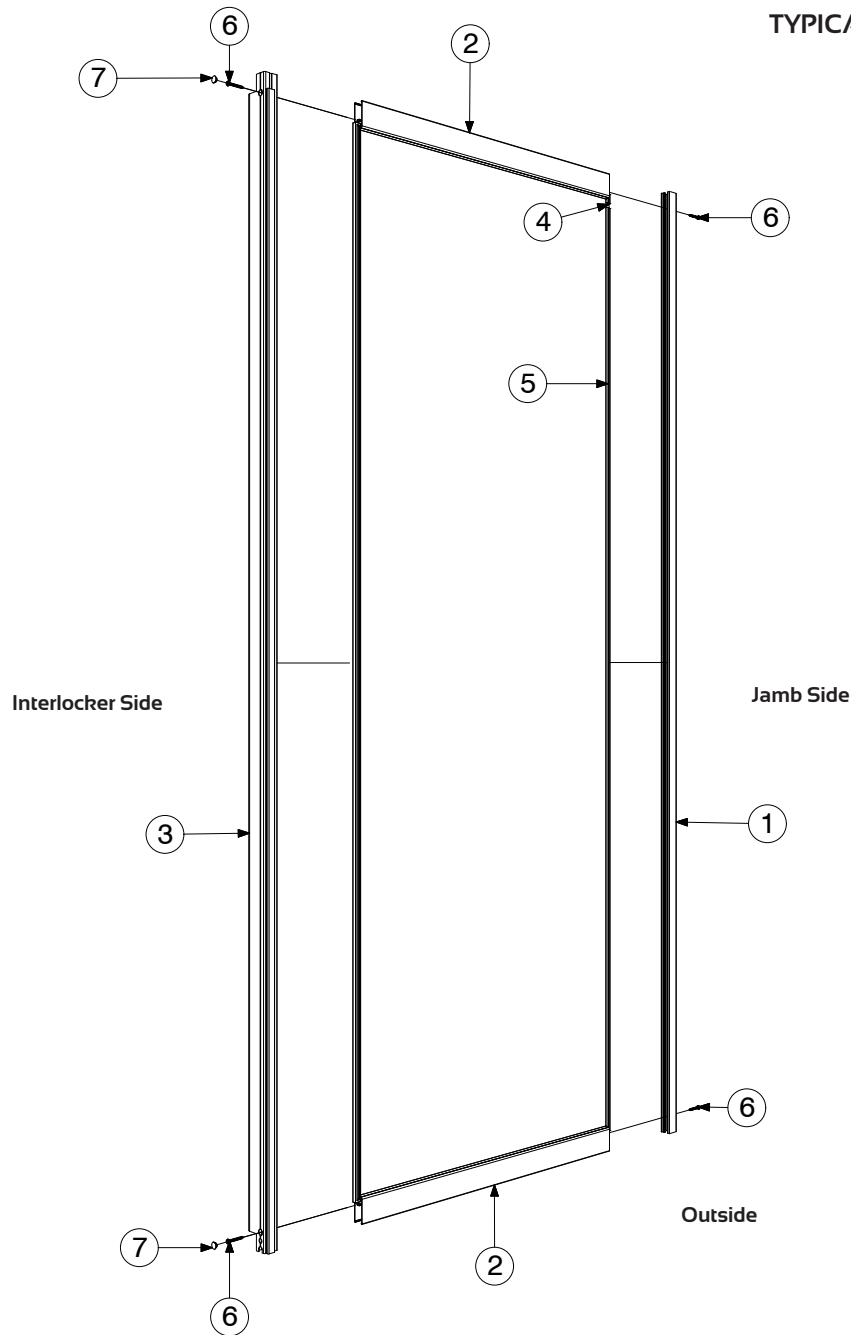

System Profiles

ITEM	QTY	DIE No.	DESCRIPTION	MACHINING
1	1	W34205	Rouge Stile Fixed	✓
2	1	W34207	Rouge Sash Head & Sill	x
3	1	W56831 W56832 W56833	Rouge Interlocker	✓
4	1	4mm 5mm 6.38mm	Glazing	

Hardware

ITEM	QTY	DESCRIPTION
5	1	Glazing Channel Gasket
6	4	Frame Screws
7	2	9mm Gomet

Note:
Once installed the fixed stile is sealed to the outer frame using approved silicone (See Cleaning & Maintenance Manual).

DOUBLE TRACK MANUAL

FIXED PANEL MACHINING DETAILS

Please note: These details pertain to the machining of profiles. Lengths of profiles and cutting lists need to be confirmed using the Startfront program to ensure compliance to the SANS Building regulations.

DIE No. W34205

Rouge Stile Fixed

Section not to scale

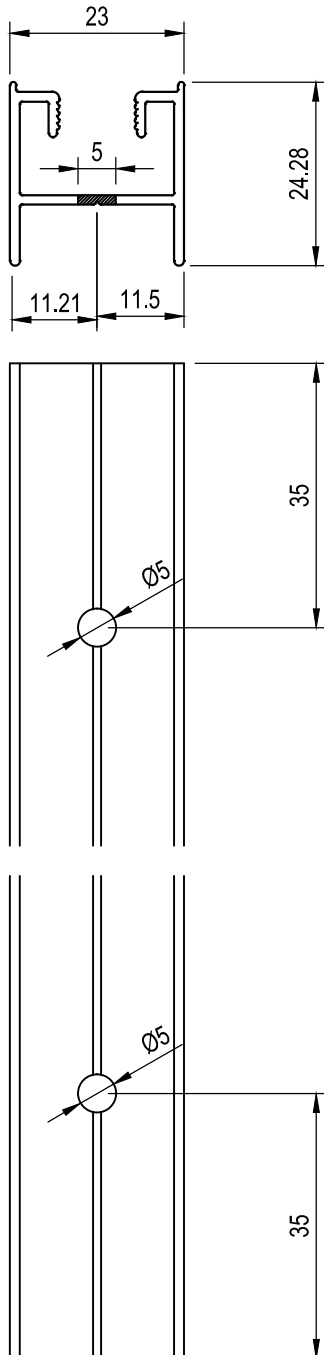

Profile Height:
Profile Height to be determined using the Starfront program to ensure compliance to SANS building specifications. Incorrect height of the profile will result in the door failing to be certified.

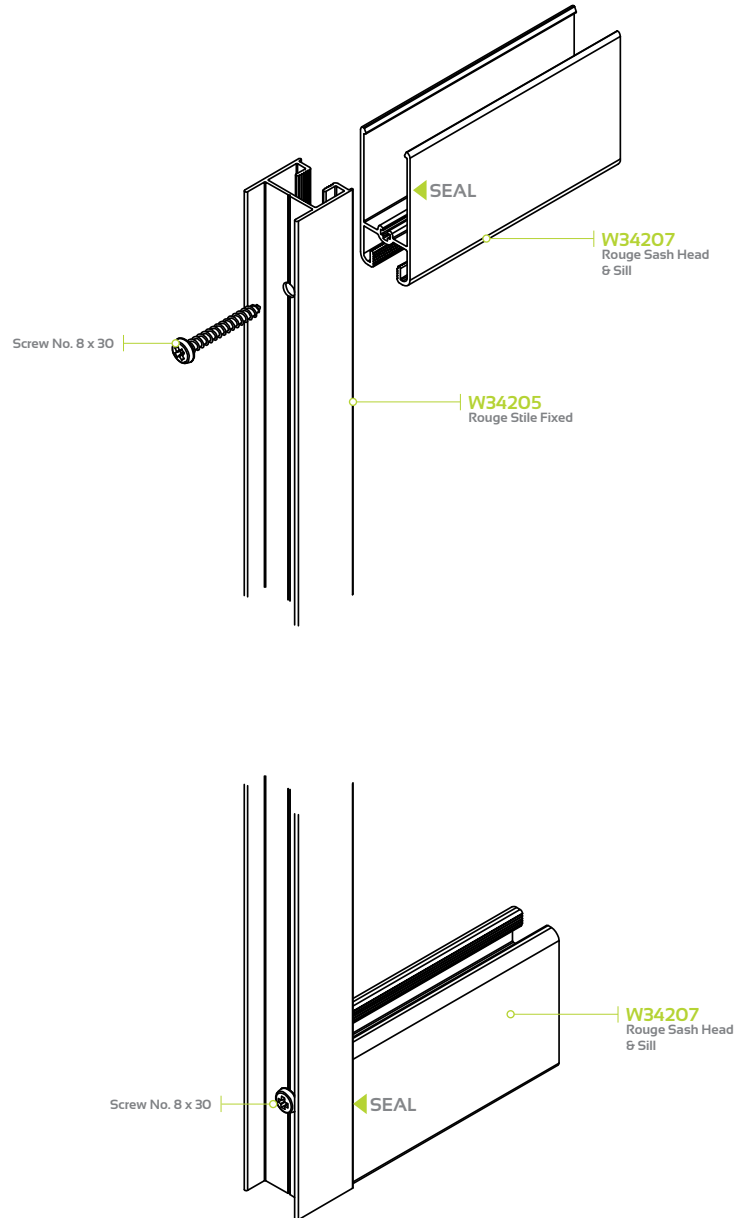

Note:
Hole accuracy is a critical value to ensure the door is square.

Important
To ensure that the system meets water ingress criteria, seal all mechanical joints with approved silicone. (See Cleaning & Maintenance Manual)

FIXED PANEL MACHINING DETAILS

Please note: These details pertain to the machining of profiles. Lengths of profiles and cutting lists need to be confirmed using the Starfront program to ensure compliance to the SANS Building regulations.

DIE No. W56831

Rouge Interlocker Standard

Section not to scale

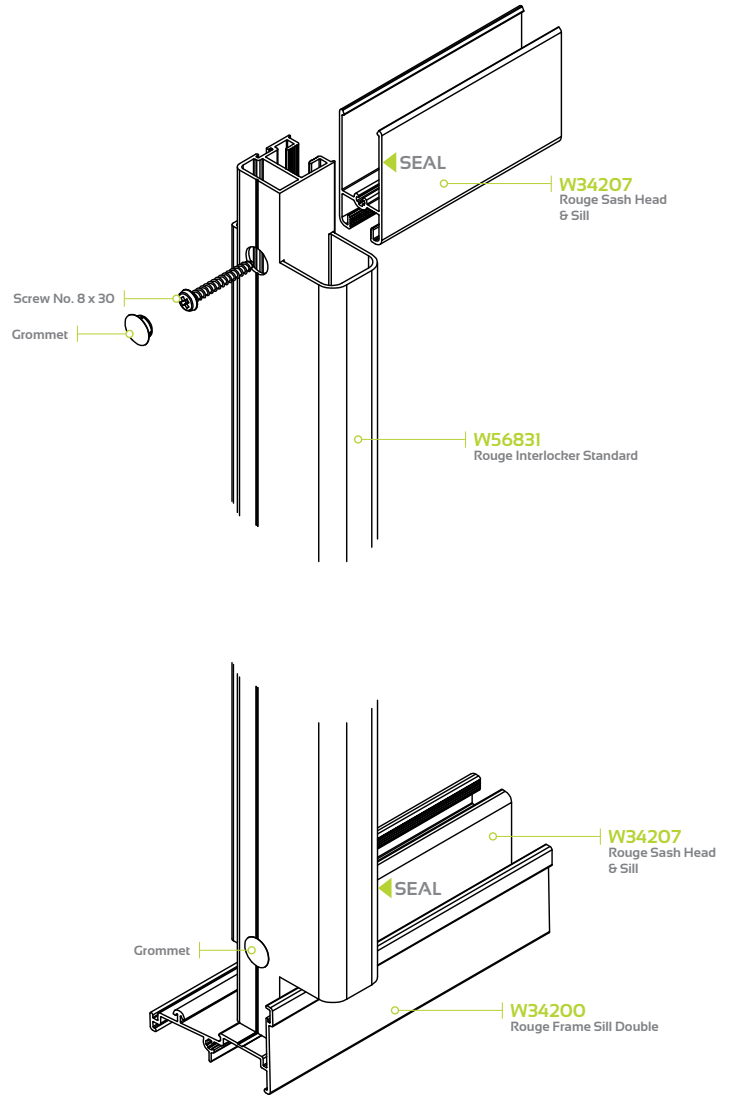
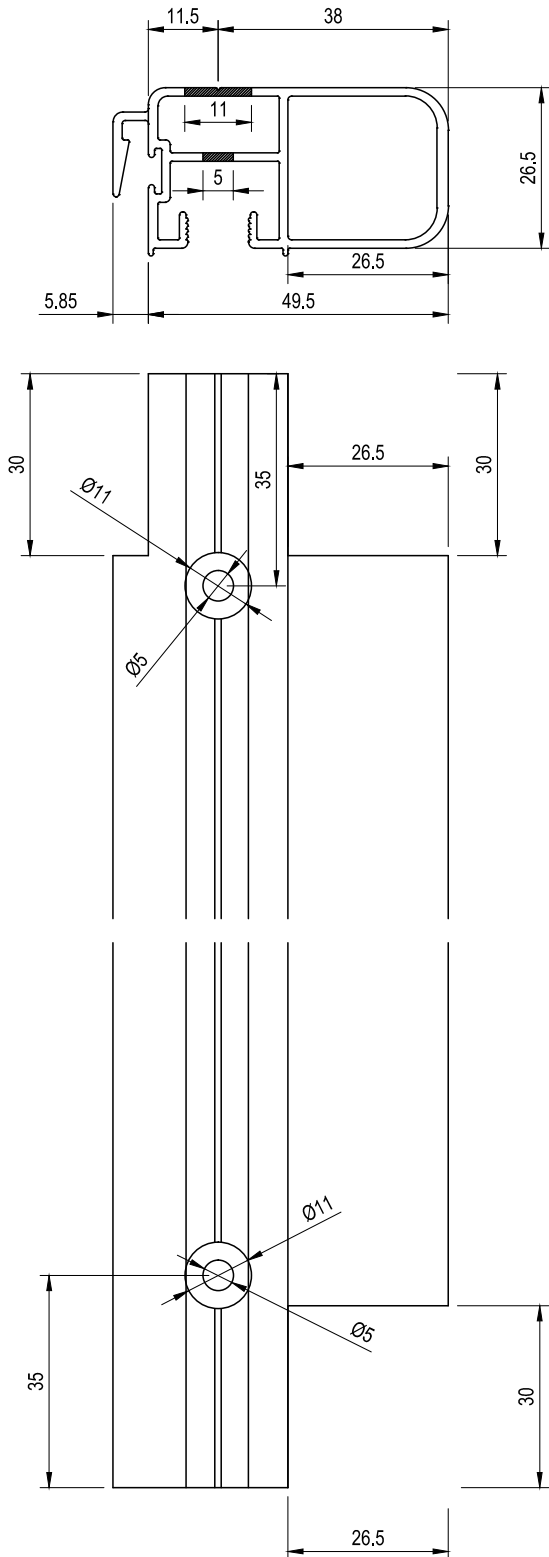

Profile Height:
Profile Height to be determined using the Starfront program to ensure compliance to SANS building specifications. Incorrect height of the profile will result in the door failing to be certified.

Important
To ensure that the system meets water ingress criteria, seal all mechanical joints with approved silicone. (See Cleaning & Maintenance Manual)

FIXED PANEL MACHINING DETAILS

Please note: These details pertain to the machining of profiles. Lengths of profiles and cutting lists need to be confirmed using the Startfont program to ensure compliance to the SANS Building regulations.

DIE No. W56832

Rouge Interlocker 60mm

Section not to scale

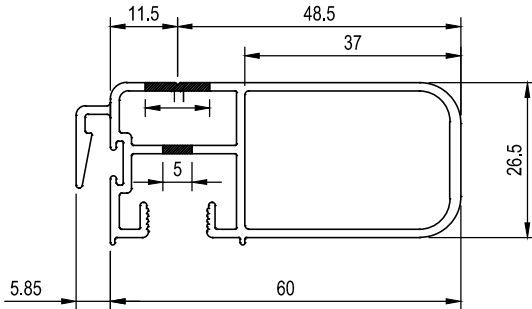

TOP

DIE No. 56833

Rouge Interlocker 75mm

Section not to scale

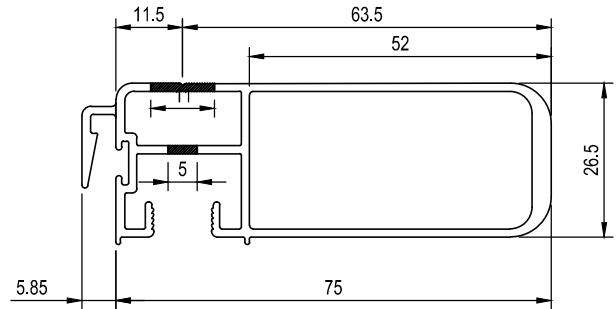

TOP

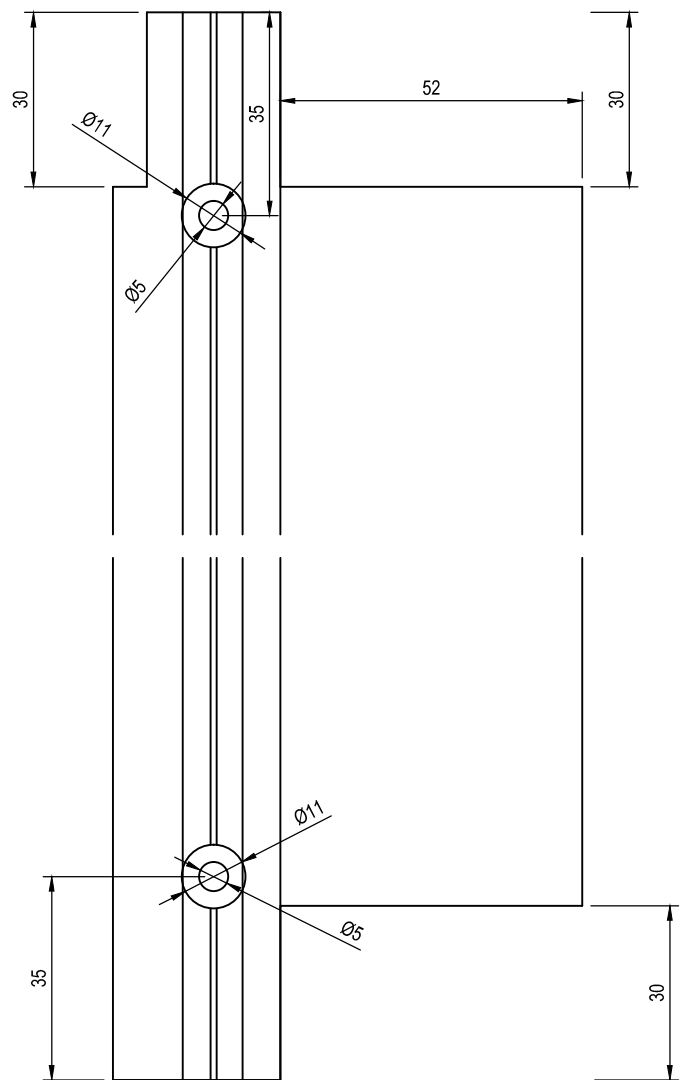
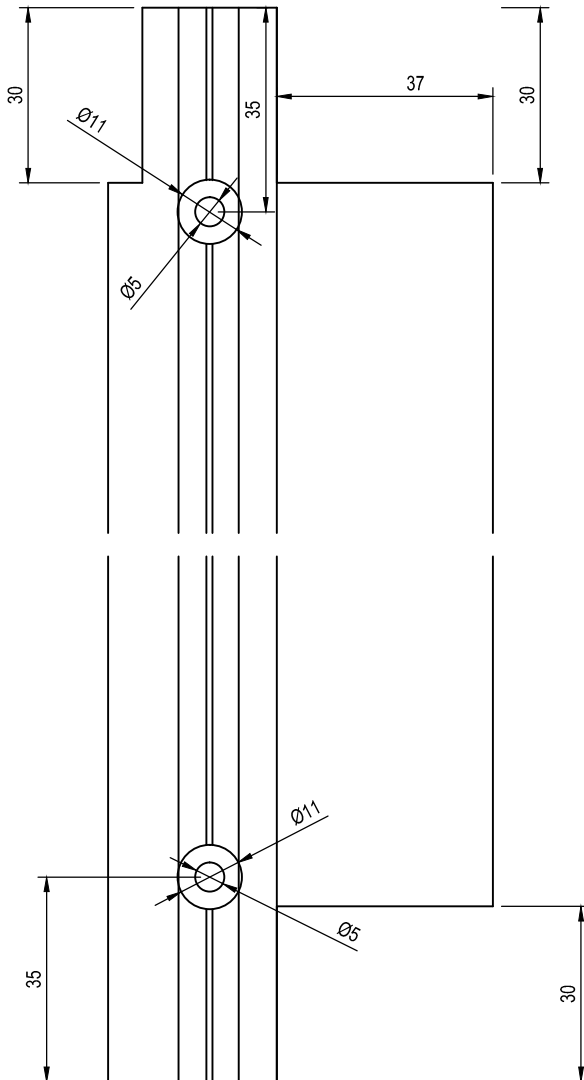

System Profiles

ITEM	QTY	DIE No.	DESCRIPTION	MACHINING
1	1	W56834	Rouge Stile Lock	✓
2	1	W34207	Rouge Sash Head & Sill	✗
3	1	W56831 W56832 W56833	Rouge Interlocker	✓
4	1	4mm 5mm 6.38mm	Glazing	

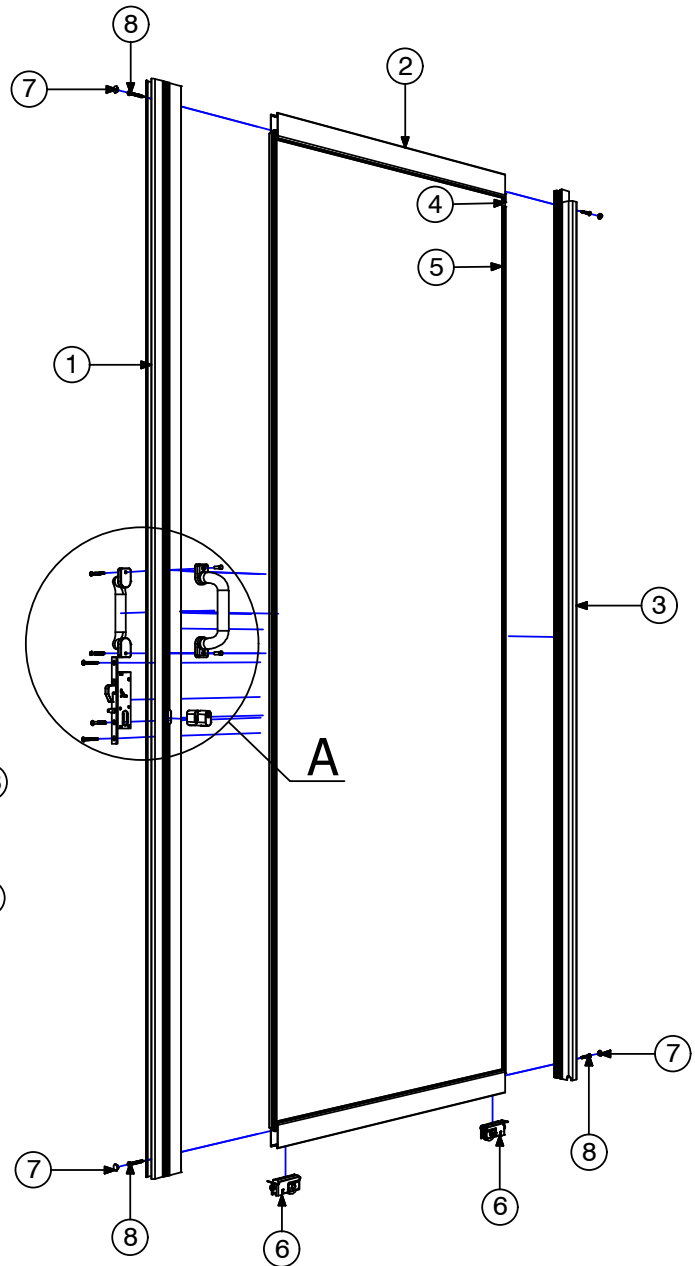
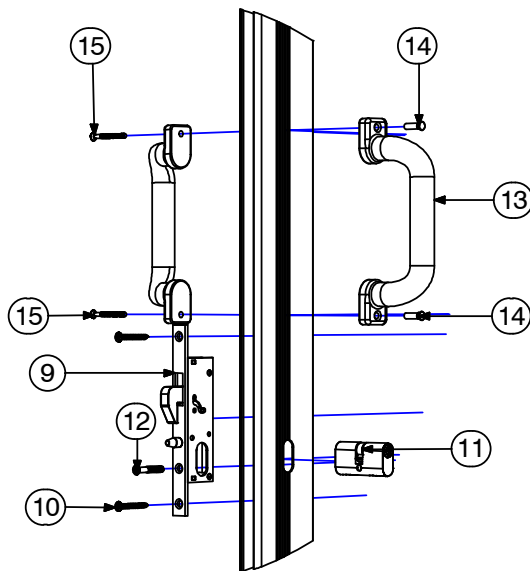

Frame Hardware

ITEM	QTY	DESCRIPTION
5	1	Glazing Channel Gasket
6	2	Standard Roller
7	4	Frame Screws
8	2	9mm Gomet

Lock Stile Hardware

ITEM	QTY	DESCRIPTION
9	1	ISEO Lock
10	2	Screw 8 x 30
11	1	ISEO Cylinder
12	1	Cylinder Screw
13	2	Regal Handle
14	2	Regal Pin Nut
15	2	Regal Adjustable Screw

Important

To ensure that the system meets water ingress criteria, seal all mechanical joints with approved silicone. (See Cleaning & Maintenance Manual)

DIE No. W56834
Section not to scale

Rouge Stile Lock

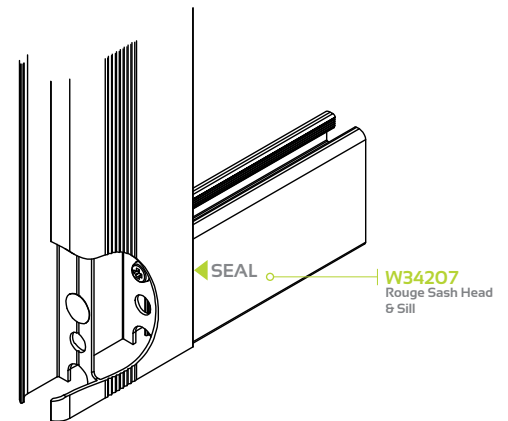
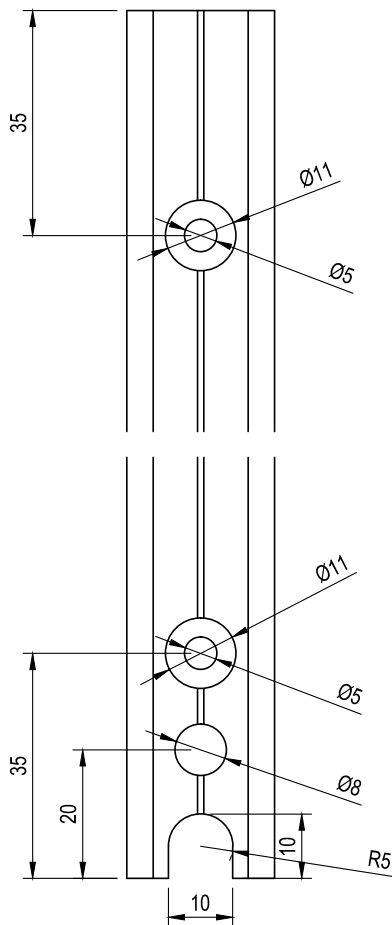
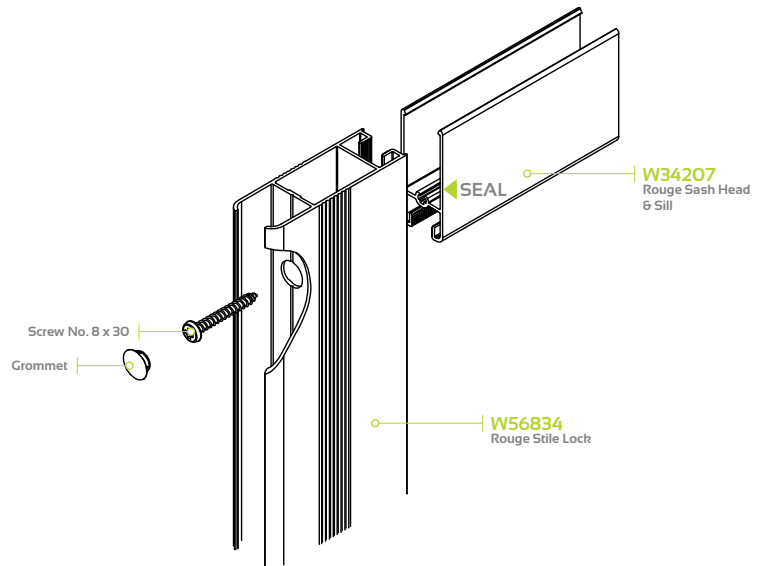
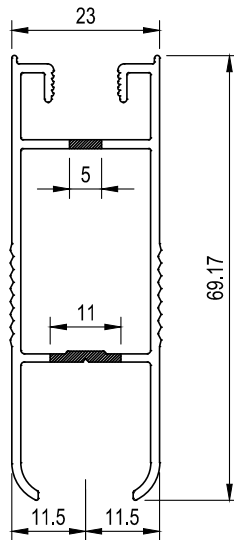

Profile Height:
Profile Height to be determined using the Starfront program to ensure compliance to SANS building specifications. Incorrect height of the profile will result in the door failing to be certified.

Important
To ensure that the system meets water ingress criteria, seal all mechanical joints with approved silicone. (See Cleaning & Maintenance Manual)

DIE No. W56834

Rouge Stile Lock

Section not to scale

Cylinder Machining Detail

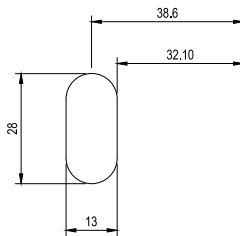
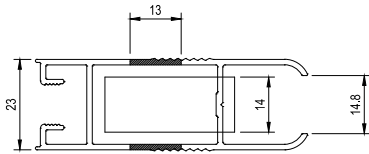

Lock Machining Detail

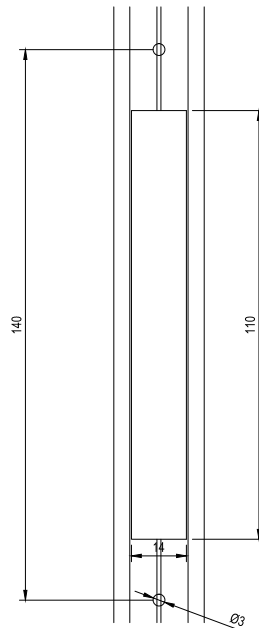
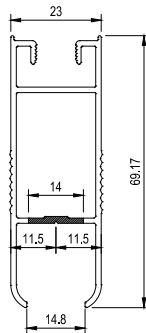

Lock Assembly

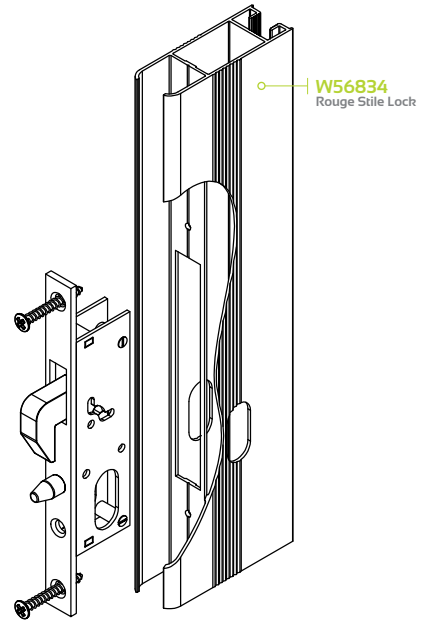

Cylinder Assembly

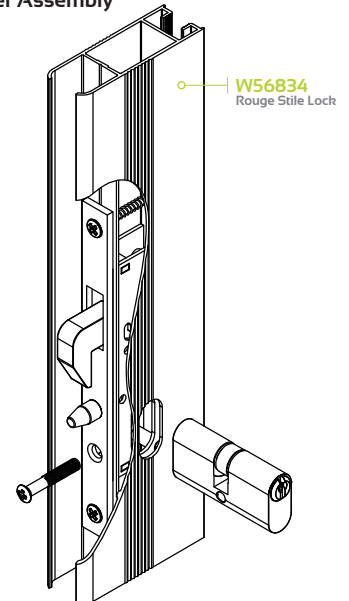

SLIDING PANEL MACHINING DETAILS

Please note: These details pertain to the machining of profiles. Lengths of profiles and cutting lists need to be confirmed using the Starfront program to ensure compliance to the SANS Building regulations.

DIE No. W56831

Rouge Interlocker Standard

Section not to scale

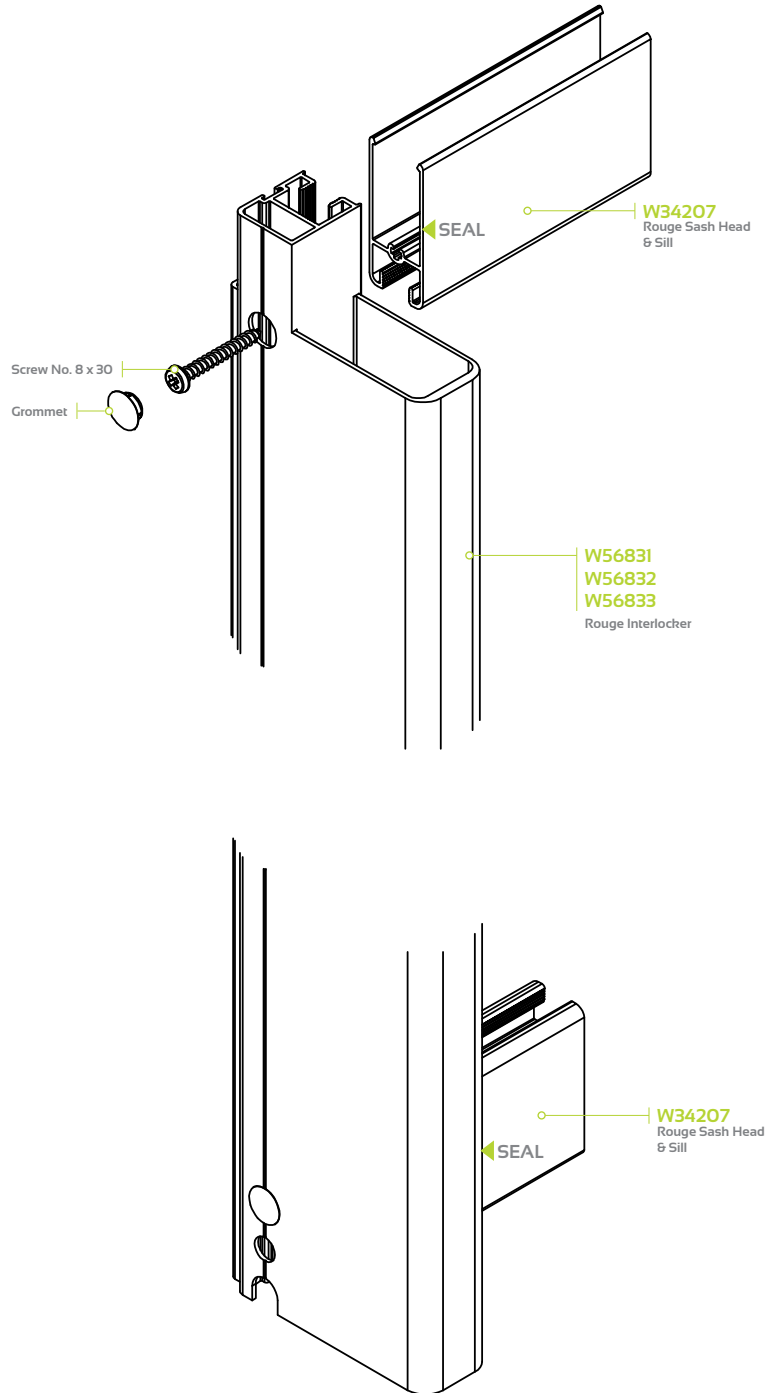
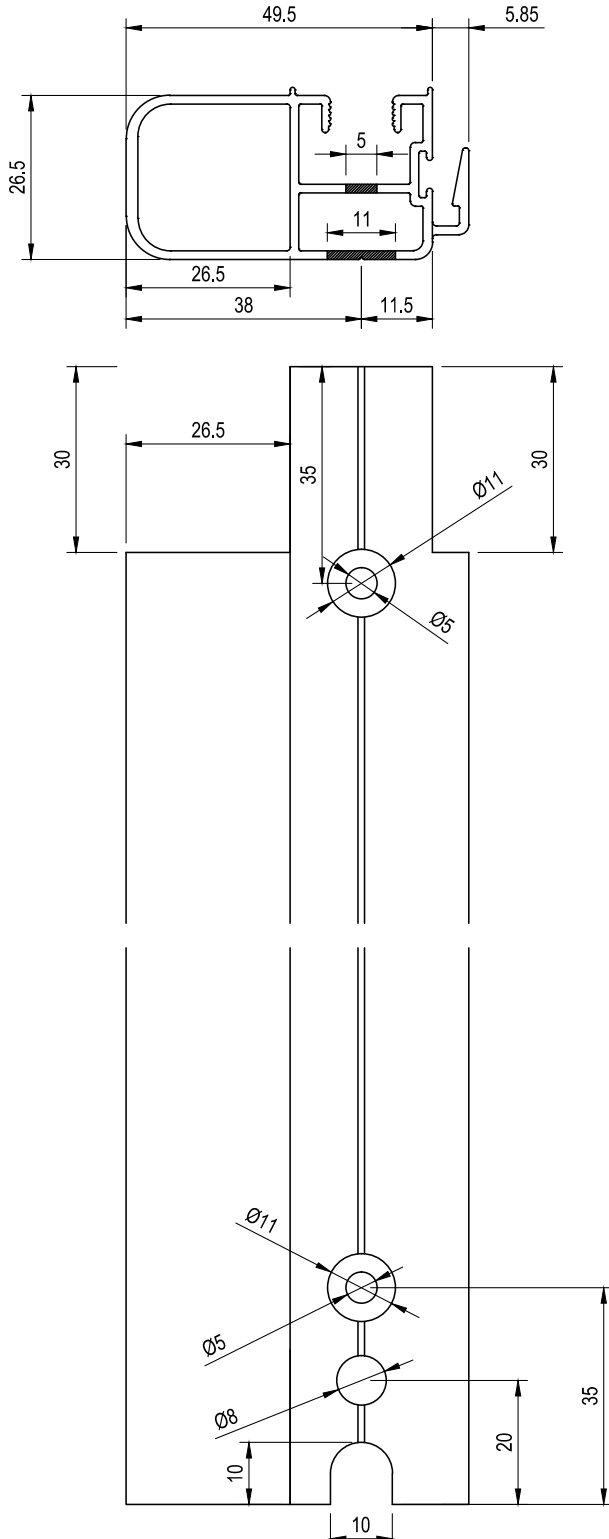

Profile Height:

Profile Height to be determined using the Starfront program to ensure compliance to SANS building specifications. Incorrect height of the profile will result in the door failing to be certified.

Important

To ensure that the system meets water ingress criteria, seal all mechanical joints with approved silicone. (See Cleaning & Maintenance Manual)

SLIDING PANEL MACHINING DETAILS

Please note: These details pertain to the machining of profiles. Lengths of profiles and cutting lists need to be confirmed using the Startfont program to ensure compliance to the SANS Building regulations.

DIE No. W56832
Section not to scale

Rouge Interlocker 60mm

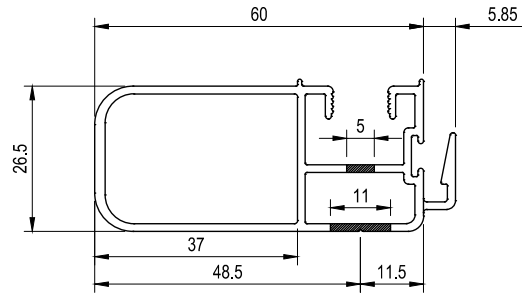

DIE No. W56833
Section not to scale

Rouge Interlocker 75mm

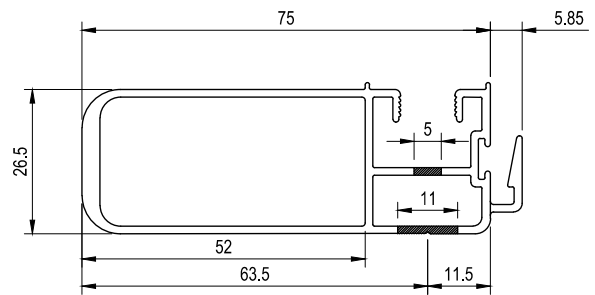

TOP

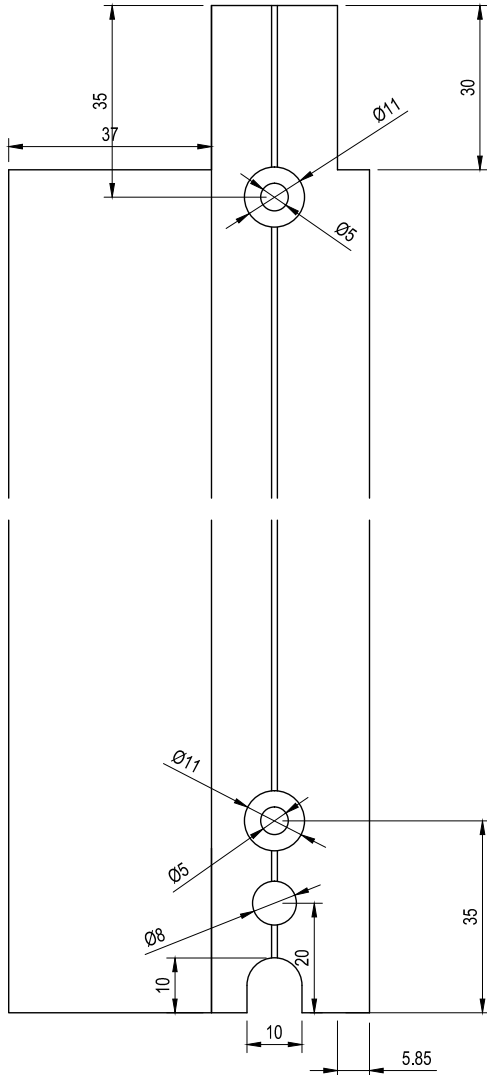

TOP

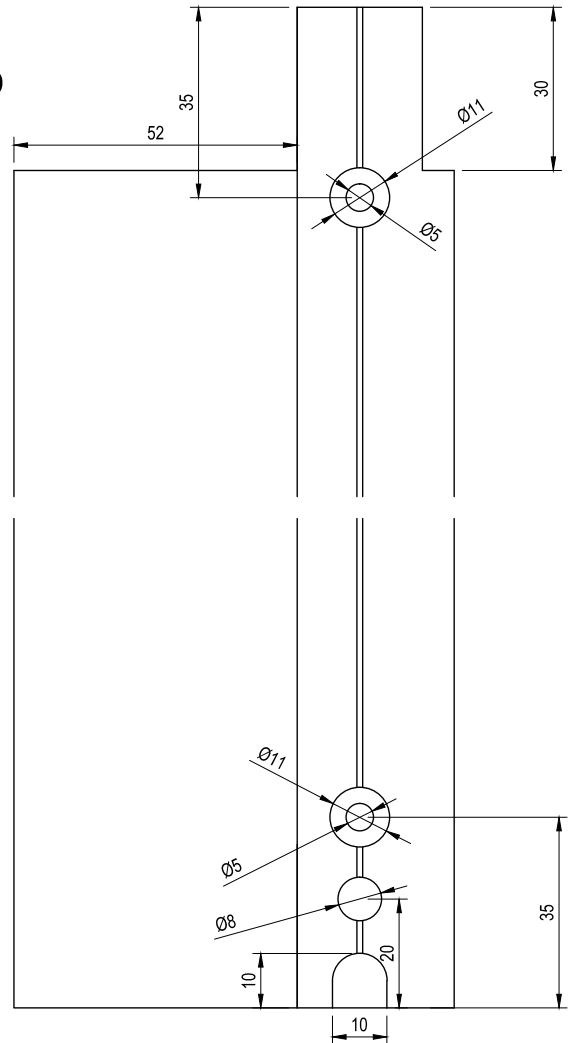

MEETING STILES



MEETING STILES OPTION

**TYPICAL CROSS-SECTIONAL DETAIL
OXXO CONFIGURATION**

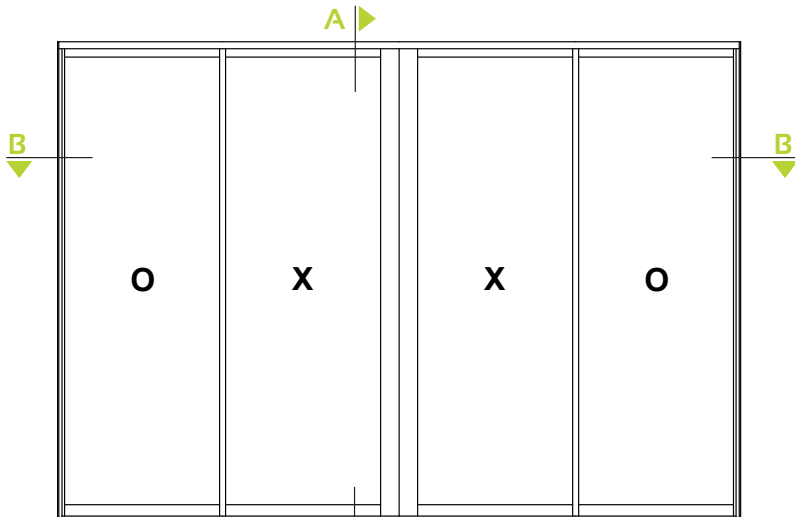

ELEVATION
Not to scale

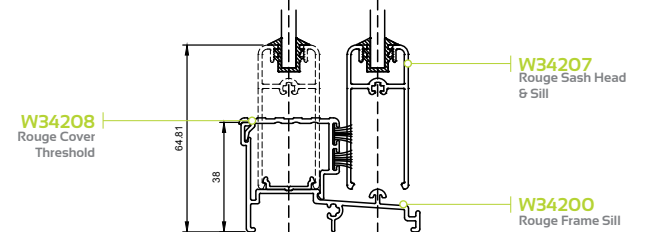
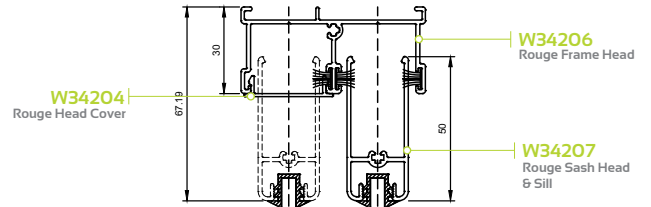

SECTION A-A
Section not to scale

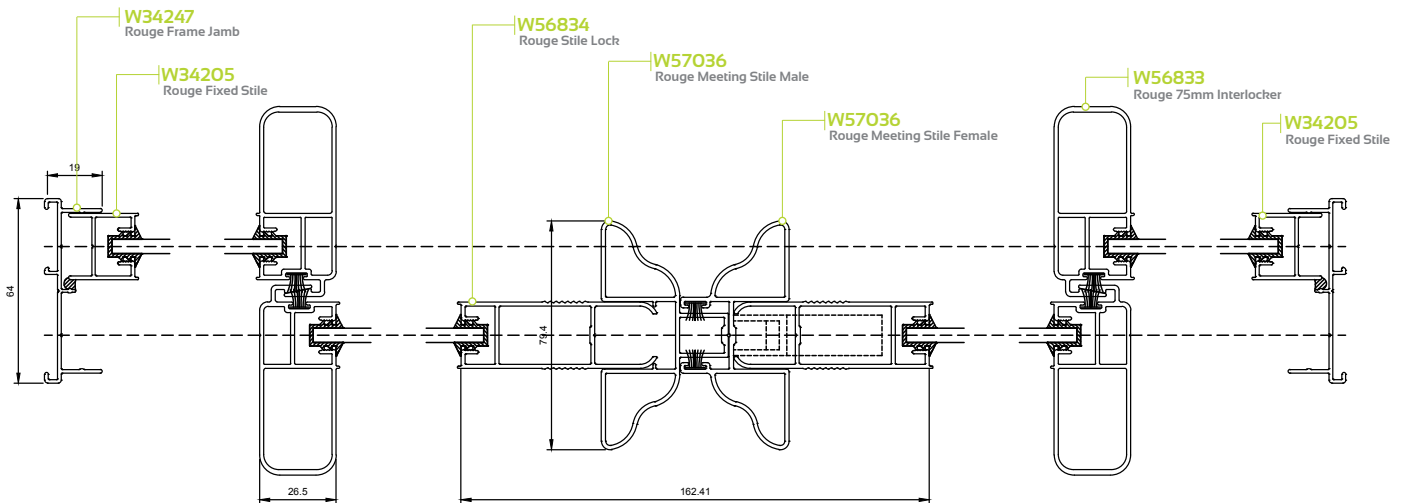

SECTION B-B
Section not to scale

MEETING STILES OPTION

MEETING STILE FEMALE MACHINING DETAILS

DIE No. W57036

Rouge Meeting Stile Female

Section not to scale

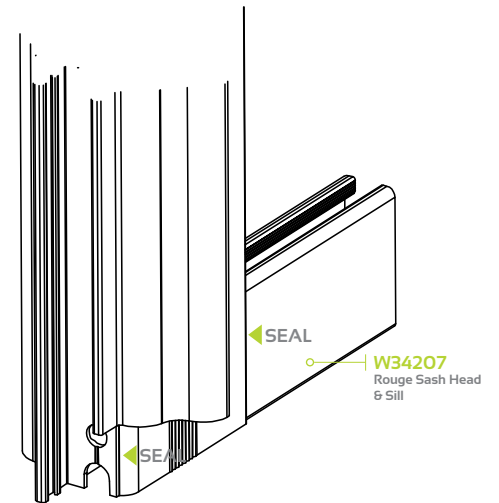
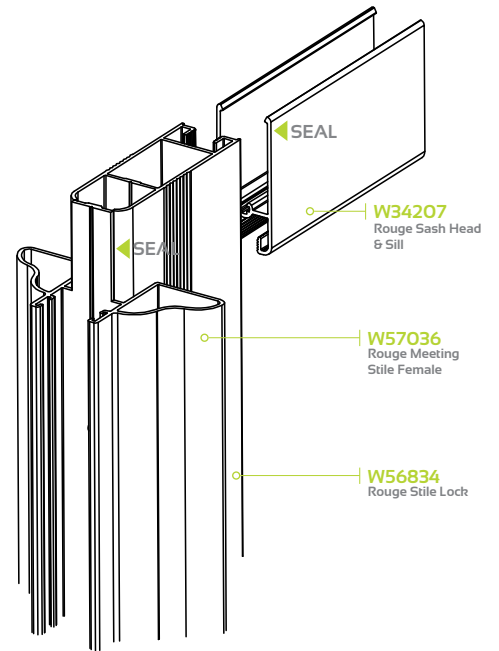
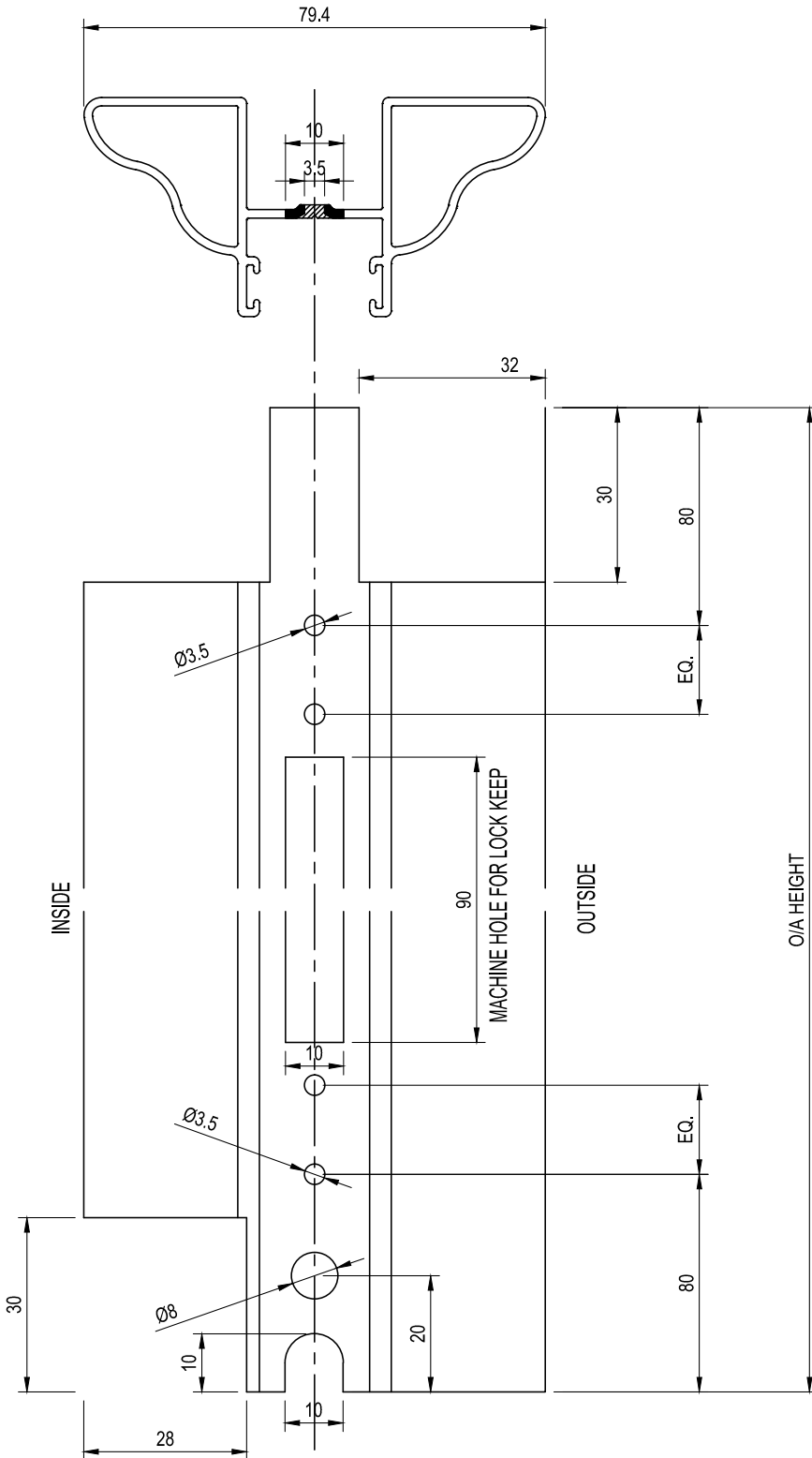

Profile Height:

Profile Height to be determined using the Starfront program to ensure compliance to SANS building specifications. Incorrect height of the profile will result in the door failing to be certified.

Important

To ensure that the system meets water ingress criteria, seal all mechanical joints with approved silicone. (See Cleaning & Maintenance Manual)

MEETING STILES OPTION

MEETING STILE MALE MACHINING DETAILS

DIE No. W57037

Rouge Meeting Stile Male

Section not to scale

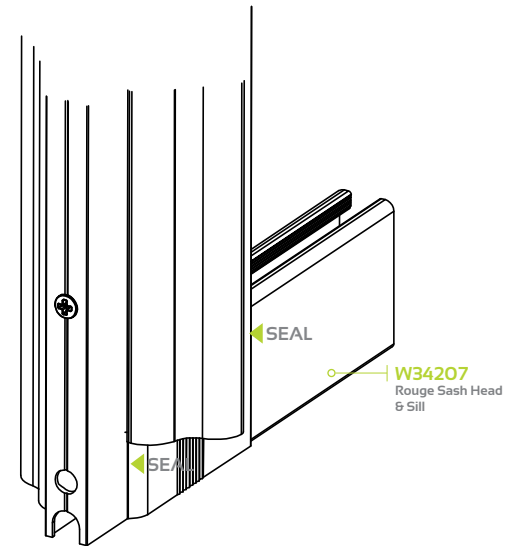
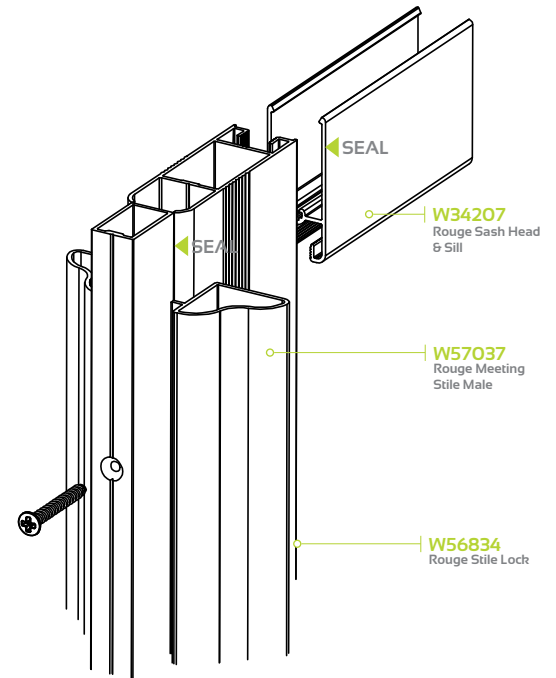
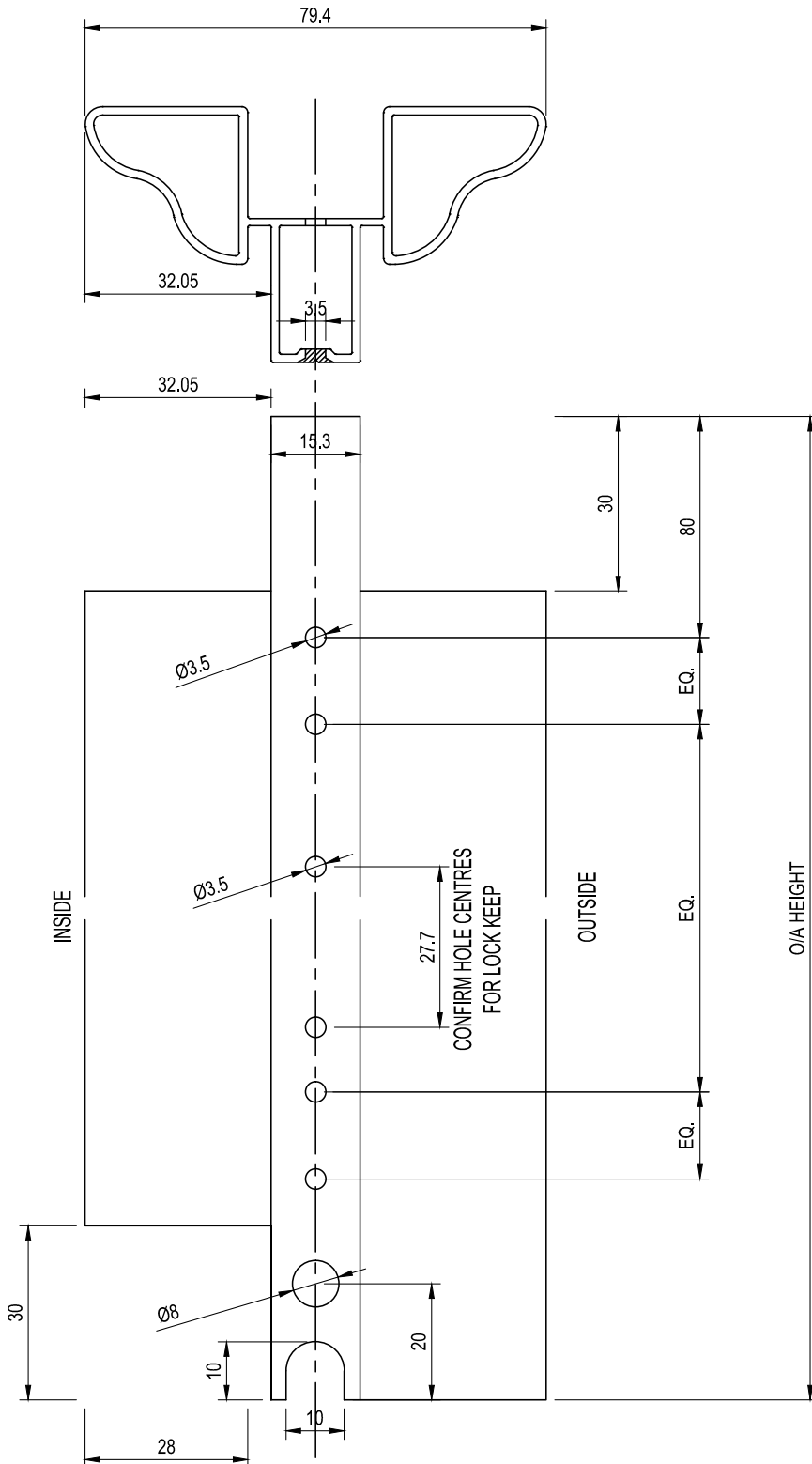

Profile Height:
Profile Height to be determined using the Starfront program to ensure compliance to SANS building specifications. Incorrect height of the profile will result in the door failing to be certified.

Important
To ensure that the system meets water ingress criteria, seal all mechanical joints with approved silicone. (See Cleaning & Maintenance Manual)

MEETING STILES OPTION

MEETING STILE OVERVIEW

1. Overview

It is important to ensure that the locking components are placed on the correct profiles and the machining is accurate.

2. Lock

The lock is located in the panel with the FEMALE Meeting Stile. The Meeting Stile is attached after the lock has been installed and tested. The machining of the opening for the lock keep is important to the correct function and engagement to the lock.

3. Lock Keep

The Lock Keep is located on the panel with the MALE Meeting Stile. The Lock Keep is attached after the Meeting Stile has been installed and checked for alignment. The location and fixation of the Lock Keep is important to the correct operation of the locking mechanism.

NOTE: Ensure that the screws used in the Lock Keep are correctly tightened.

Meeting End Caps

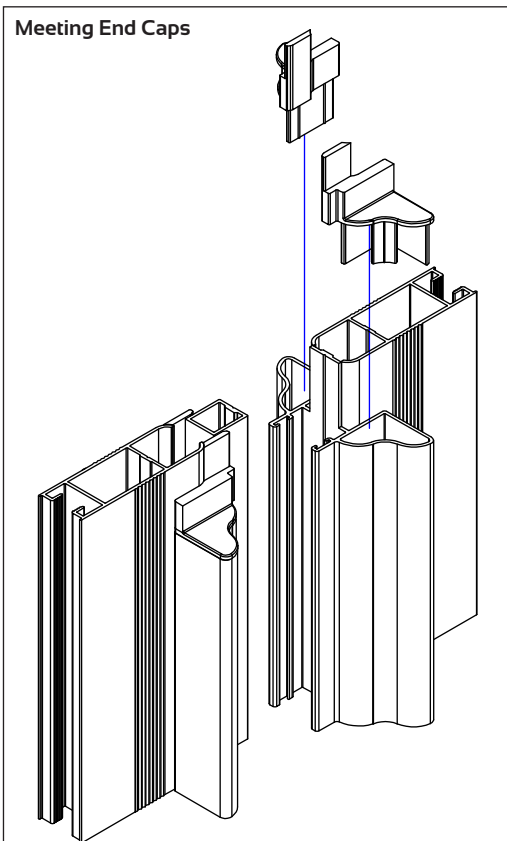

Meeting Stile Lock Detail

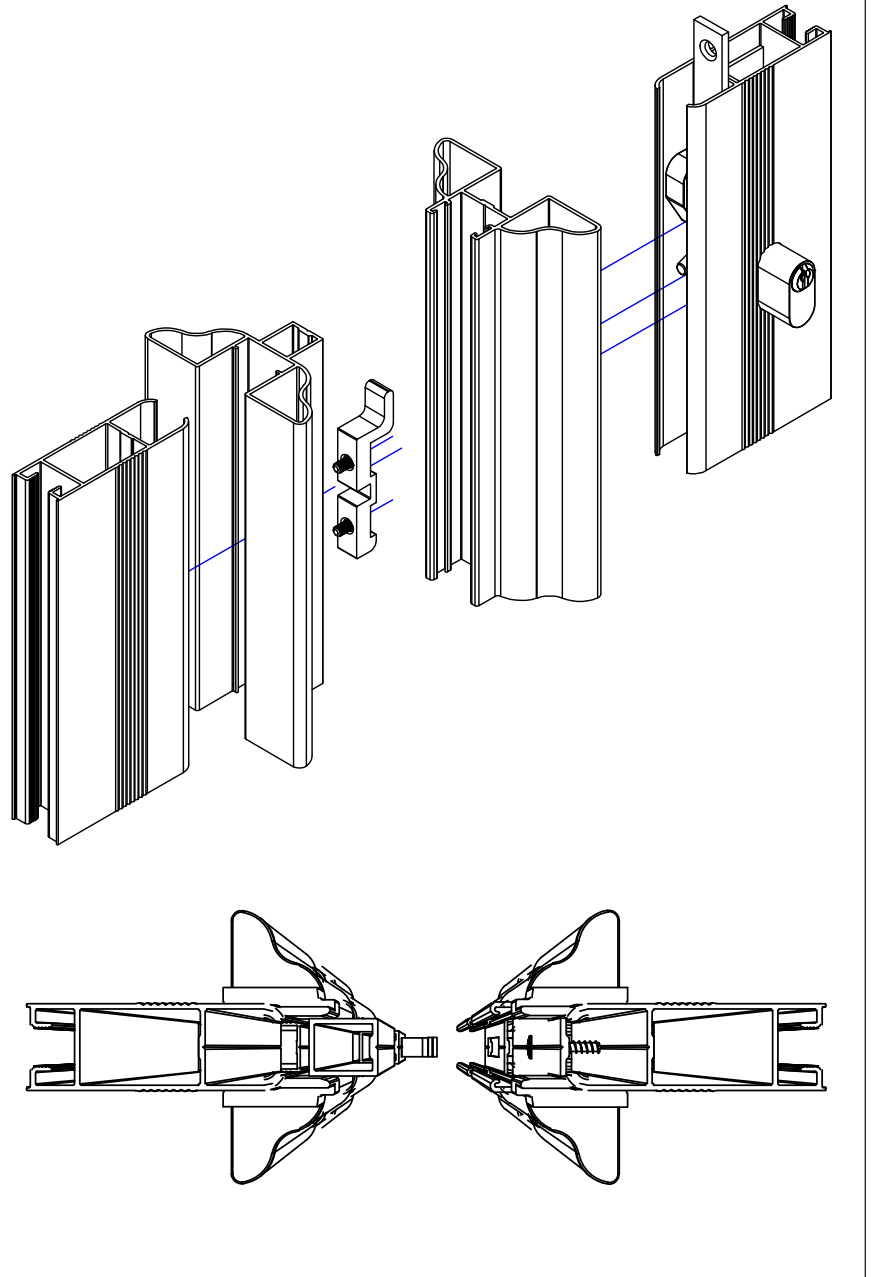

GENERAL COMPONENTS



INSTALLATION

FIXING LUG DETAILS

Please note: These details pertain to the machining of profiles. Lengths of profiles and cutting lists need to be confirmed using the Startfont program to ensure compliance to the SANS Building regulations.

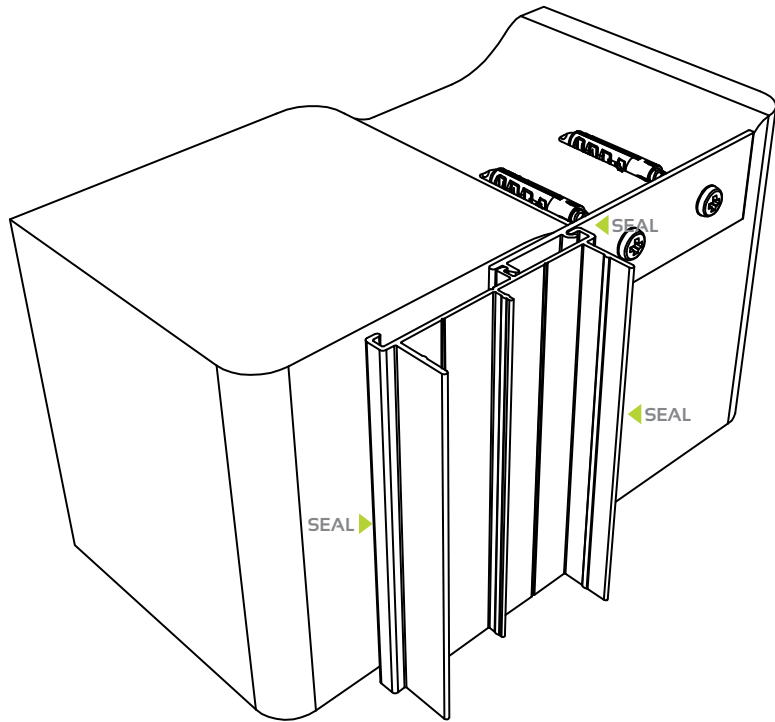
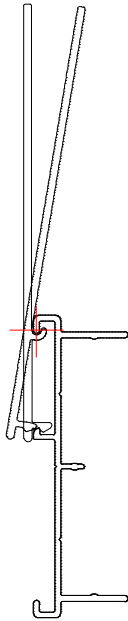

The Fixing Lug is an optional method of fastening the door to the structure. Lugs can be cut to 25mm lengths and drilled to suite your preferred installation method. The spacing and method of fixation will need to be approved by a structural engineer.

Please note: This is a guideline on the installation process of a standard OX & OXXO Door.

Double Track Installation

1. Install Outer Frame

Install the outer frame into the structure or void using preferred method. (see Fixing Details for correct fixation dimensions).

Ensure that the Outer Frame is square, plumb and that all dust and grime is remove. Ensure all joints are sealed sufficiently and that all joints are weather resistant. (Remember to fit the Finseal)

2. Install Fixed Panel Adapter

Install the fixed panel adapter. (see Fixing Details for correct fixation dimensions)

3. Install Fixed Panel

Install the fixed panel (see Figure 1).

Install the panel by inserting the panel into the head channel. Lift and swing the panel over the Fixed Panel Adapter. Ensure that the adapter engages the bottom of the panel and that it is square.

4. Silicone Fixed Panel

Silicone the Fixed Panel to the Outer Frame externally.

5. Install Outer Frame Components

Install the Threshold and the Head Cover into the same channel as the fixed frame. Ensure that the outer frame is free from debris before installation as this can impair the engagement of the profiles.

Ensure the Finseal has been inserted into these components prior to installation. Please ensure that the Finseal is cut 15 mm longer than the Threshold & Head cover to overlap the interlocker, ensure that the Finseal cannot slide out with the moving of the panels.

6. Install Sliding Panel(s)

Install the Sliding Panels into the Outer Frame beginning with the channel closest to the Fixed Panel.

Ensure that the Rollers are in their lowest position to ensure no interference with the installation of the panel over the Tracks.

7. Door / Lock Adjustment

Ensure that the Rollers are in their lowest position to ensure no interference with the installation of the panel over the Tracks.

Once the Sliding Panel is in place adjust the Rollers to the correct height. In the case of the Sliding Panel with the lock, align the lock to the correct height. The lock keep is adjustable as well to allow for a small tolerance to cater for any settling.

8. Weatherproofing

Apply silicone to the joint between the Outer Frame and the structure paying extra attention to the corner joint areas.

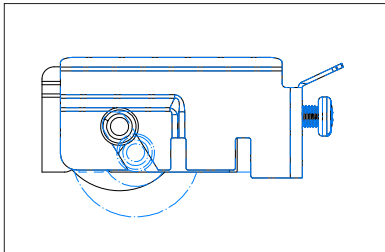
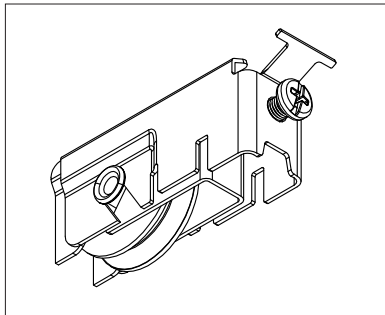
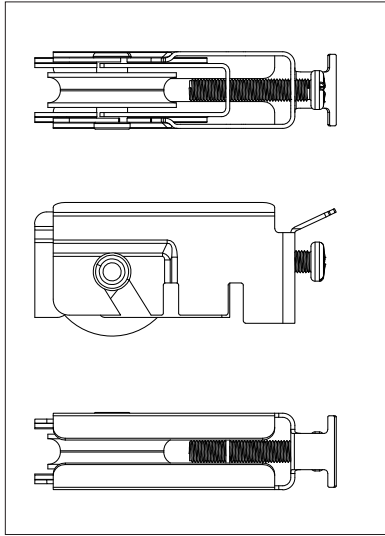

Roller Specification

This manual depicts the standard patio door roller as shown which is available from Crealco Components. The principles of placements and adjustments are shown as below.

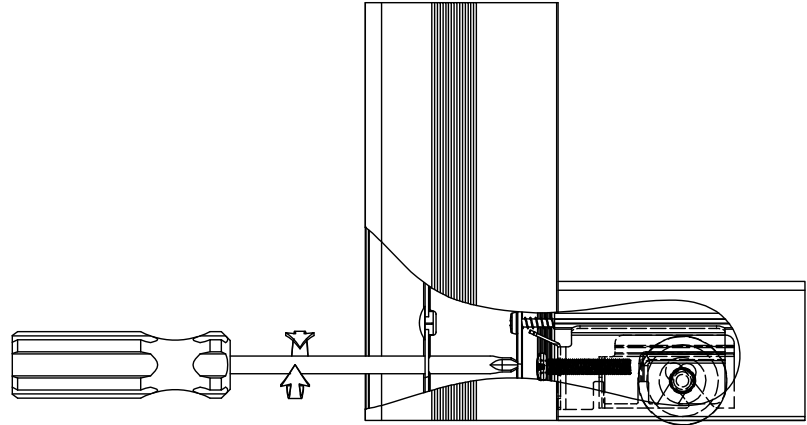

Roller Adjustment

The roller should be installed in its lowest position, this will make installing the panel with the end caps in place into the outer frame easier. To raise the roller a phillips or flat screwdriver is inserted through the adjustment hole and turned clockwise. To lower the roller turn anti-clockwise.

