

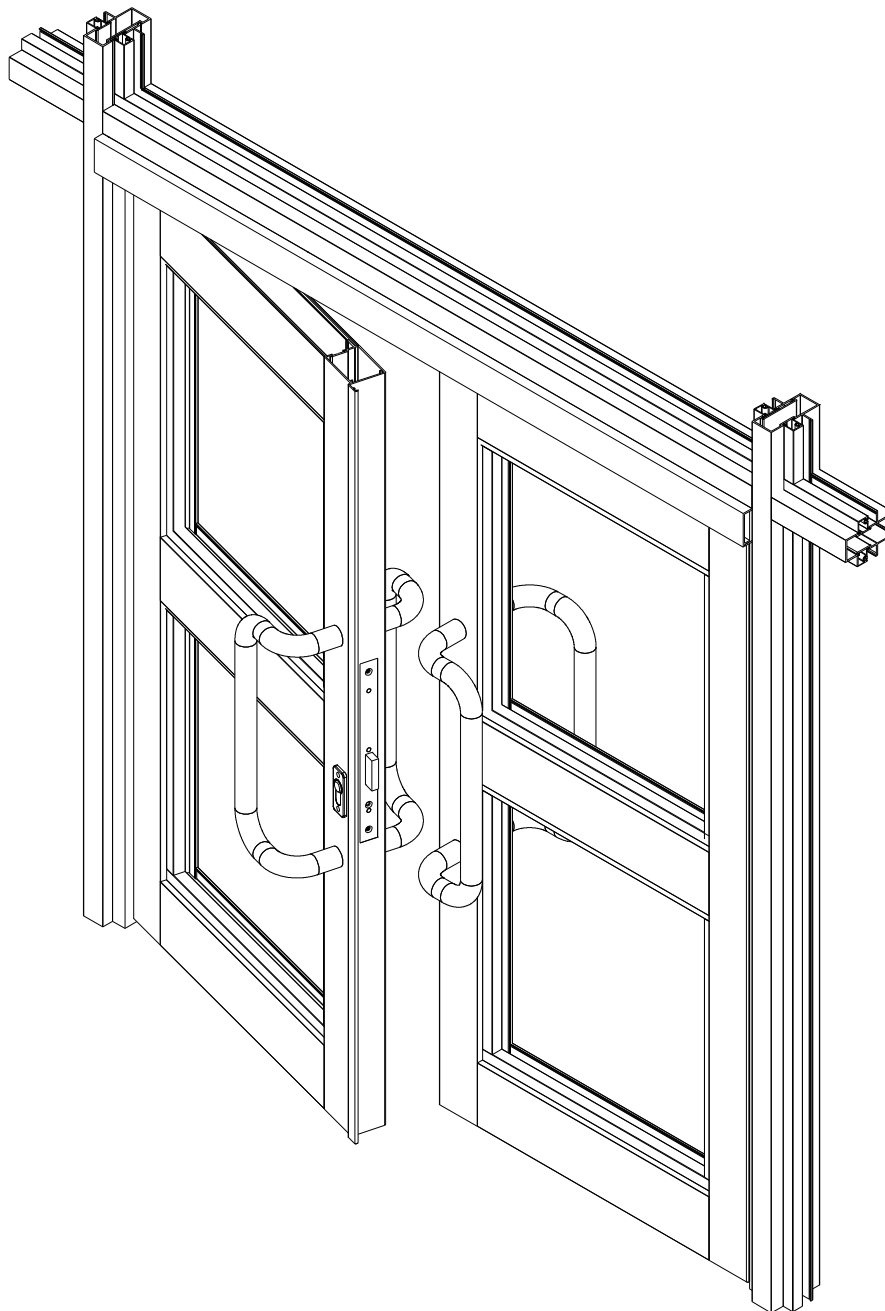

crealco |

CLIP44
OHDC

CLIP44 SHOPFRONT SYSTEM OVERHEAD DOOR CLOSER DOOR



PRODUCT MANUAL

Disclaimer: The right to make alterations is reserved

© 2013 Wispeco (Pty) Ltd, All Rights Reserved

Revision: June 2013



Index

Legal Disclaimer	3
Profile Identification	4-6
Profile Identification – Alternative Profiles With Woolpile	7
Profile Identification	8-9
Door Insert Hardware Identification	10-11
Butterfly Gasket and Wedge Codes	12
Door Leaf Size Limitation Guide	13
Typical Configurations	14
Door Fixing Details	15
Single OHDC Door Cross Sectional Detail	16
Single OHDC Door With Midrail Cross Sectional Detail	17
Double OHDC Door Cross Sectional Detail	18
Double OHDC Door With Midrail Cross Sectional Detail	19
Component Assembly Detail	20
Door Sill Machining Detail To Suit All Sill Combinations	21
Sill Combinations	22
Sill Floor Level Detail	23
Swing Door Midrail Machining Detail To Suit All Combinations	24
R4 Filler Adaptor Machining Detail	25
Midrail Combinations	26
Spigot Machining Detail <W26197>	27
Door Stile Machining Detail	28
Rod & Spigot Assembly Detail	29
Door Handle Machining Detail <HNDD25300N>	30
Meeting Stile Machining Detail For Lock <CL44640/25>	31
Transom & Transom Cover Machining Detail <CC900>	32
Jamb Machining Detail <CC900>	33
Head Machining Detail <CC900>	34
Sill Machining Detail <CC900>	35
Setting Block Location	36

This manual must be read in conjunction with the Installation, Cleaning and Maintenance Document, BEE Certificates and the Performance Certificates for the relevant system. The manual must also be used in conjunction with the design and cutting list from the latest version of StarFront.

Disclaimer: The right to make alterations is reserved

© 2012 Wispeco (Pty) Ltd, All Rights Reserved



LEGAL DISCLAIMER

All information, recommendations or advice contained in this documentation is given in good faith to the best of Wispeco's knowledge and is based on current procedures in effect.

Since the actual use of this documentation by the user is beyond the control of Wispeco, such use is within the exclusive responsibility of the user. Wispeco cannot be held responsible for any loss incurred through incorrect or faulty use of this documentation.

Great care has been taken to ensure that the information provided is correct. Wispeco will accept no responsibility for any errors and/or omissions, which may have inadvertently occurred.

All mechanical joints must be sealed with a Wispeco approved joint sealer.

Laminated glass must not stand in water.

All drawings in the Wispeco Documentation are shown NOT to scale.

Wispeco cannot accept responsibility for the use of standard products since Wispeco does not know where these products are being installed.

The use of anti-magnetic stainless steel screws and pop rivets is recommended to reduce galvanic corrosion in harsh environments.

The hardware recommended in this documentation is suitable for use in most atmospheric environments. When hardware is used in severe coastal environments the manufacturer of the hardware must be consulted.

Fixing lugs on frames must be positioned as per the user manual and used in accordance to the AAAMSA specifications. When profiles are screwed together the screw centers must also be according to the user manual.

All glass used within Wispeco products must comply with SAGGA regulations.

All glazing above 10m from ground level must be signed off by a competent person (Glazing) in accordance with the national building regulations

By continuing to use this documentation you acknowledge that you understand and accept the legal disclaimer.

CLIP44 SHOPFRONT SYSTEM OVERHEAD DOOR CLOSER DOOR PROFILE IDENTIFICATION

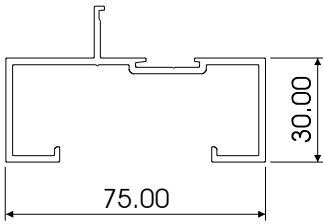

CLIP44 26C JAMB
OPEN BACK
W26154

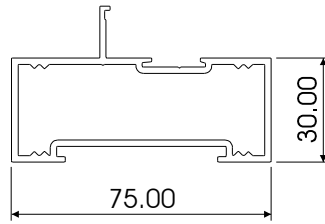

CLIP44 26B
RECESSED BACK
W44084

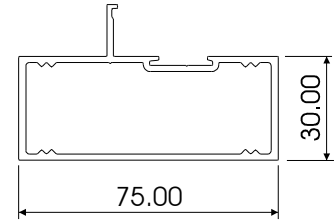

CLIP44 26E
FLAT BACK
W53194

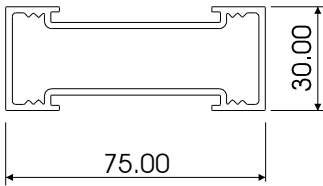

CLIP44 26D
RECESSED BACK
W53365

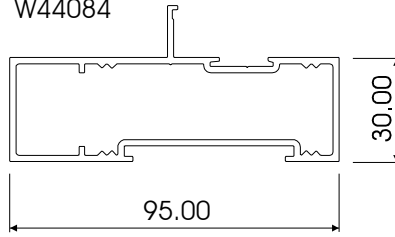

CLIP44 95B
RECESSED BACK
W55365

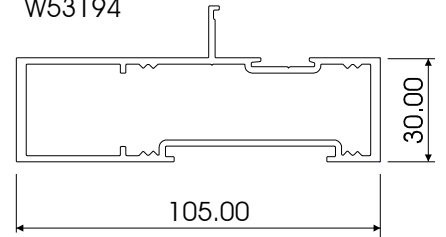

CLIP44 105B
RECESSED BACK
W55364

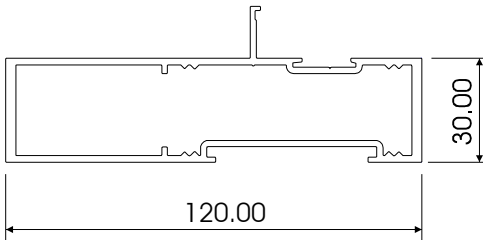

CLIP44 120B
RECESSED BACK
W55363

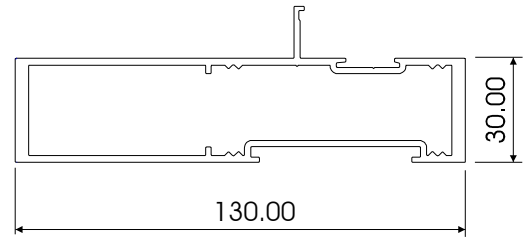

CLIP44 130B
RECESSED BACK
W56084

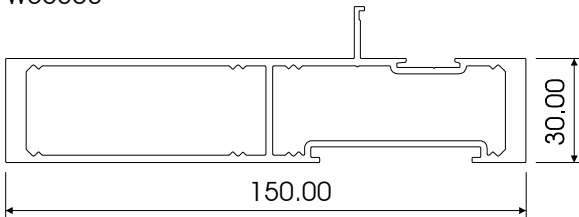

CLIP44 150B
RECESSED BACK
W55362

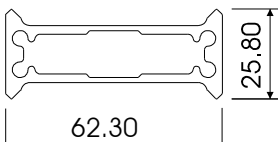

CLIP44 BOX SPIGOT
4 X S/PORT
W55456

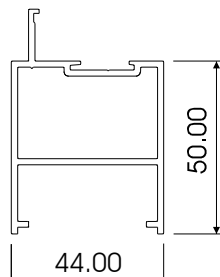

CLIP44 R7 HEAD/
SILL RAIL 50mm
W44087

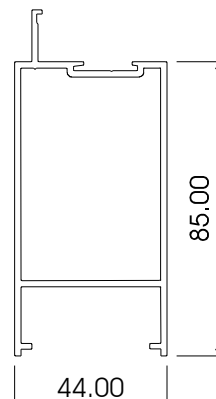

CLIP44 R4 HEAD/
SILL RAIL 85mm
W44088

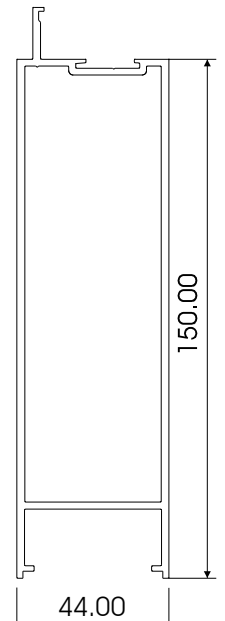

CLIP44 R6 SILL
RAIL 150mm
W44094

Disclaimer: The right to make alterations is reserved

© 2012 Wispeco (Pty) Ltd, All Rights Reserved

PAGE 4



CLIP44 SHOPFRONT SYSTEM OVERHEAD DOOR CLOSER DOOR PROFILE IDENTIFICATION

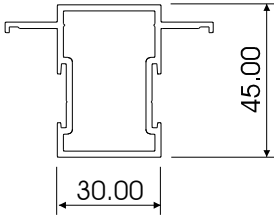

CLIP44 MIDRAIL GLAZING BAR
W53033

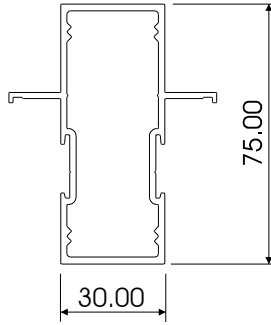

CLIP44 26 MULLION
W44083

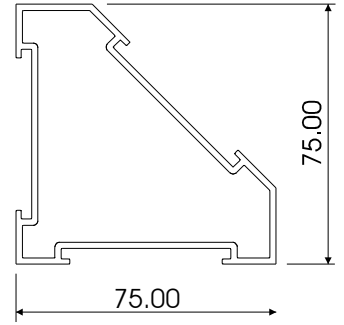

CLIP44 CORNER MULLION
W53029

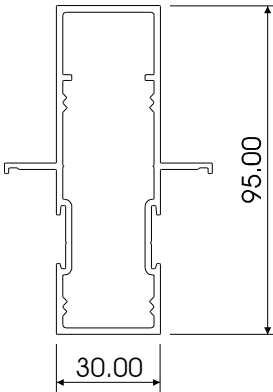

CLIP44 MULLION W95
W44090

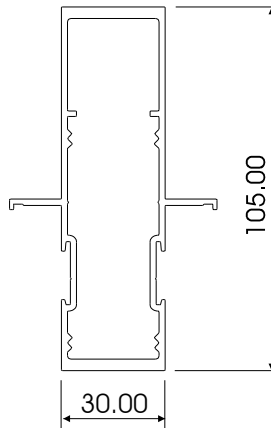

CLIP44 MULLION W105
W44091

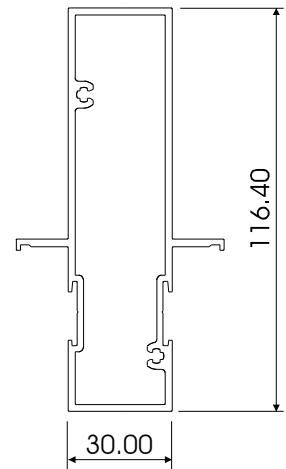

CLIP44 MULLION 116.4mm
W53305

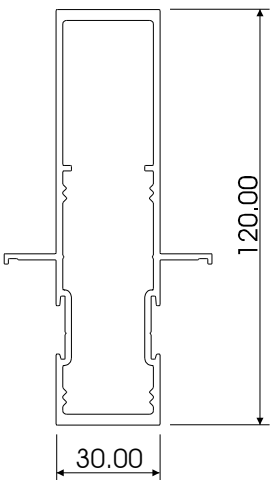

CLIP44 MULLION W120
W44092

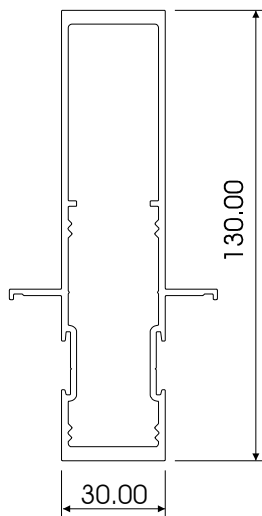

CLIP44 MULLION W130
W56083

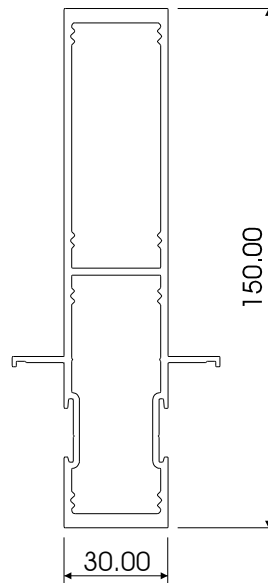

CLIP44 W150 MULLION
W53151

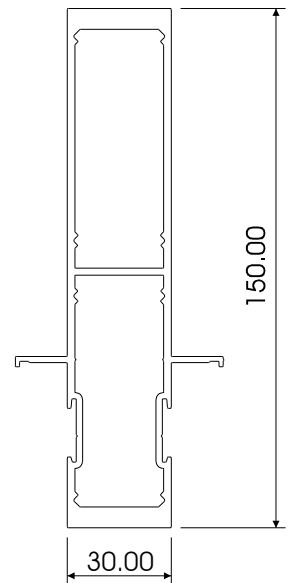

CLIP44 150mm MULLION
HEAVY DUTY
W54043

CLIP44 SHOPFRONT SYSTEM OVERHEAD DOOR CLOSER DOOR PROFILE IDENTIFICATION

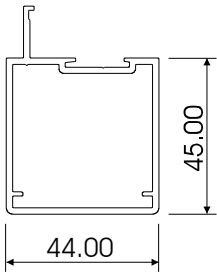

CLIP44 R1
DOOR JAMB
W44085

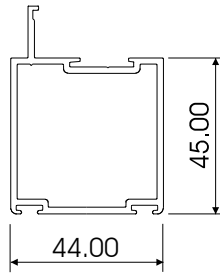

CLIP44 R3 SPECIAL
DOOR JAMB
W44093

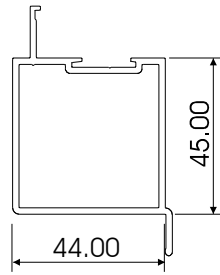

CLIP44 R12 DOUBLE
DOOR JAMB
W44086

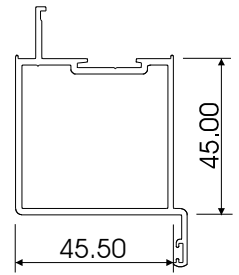

CLIP44 R12 SPECIAL
W44099

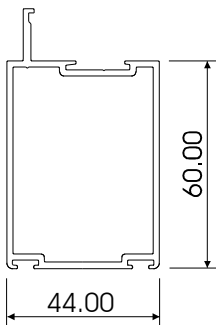

CLIP44 R11W
D/STILE 60mm W/PILE
W53666

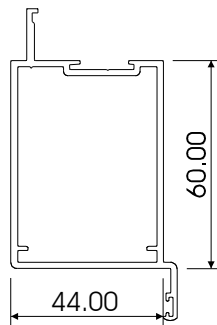

CLIP44 R11SP
D/STILE 60mm
W53566

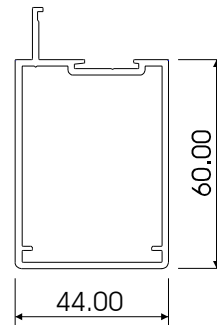

CLIP44 R11
DOOR JAMB
W53099

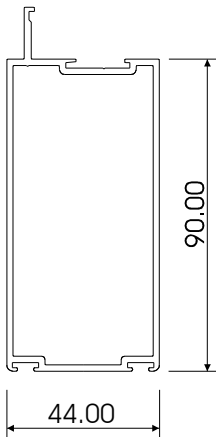

CLIP44 R9W
D/STILE 90mm W/PILE
W53407

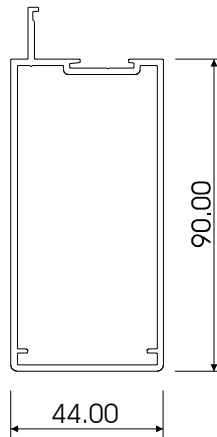

CLIP44 R9
D/STILE 90mm
W53406

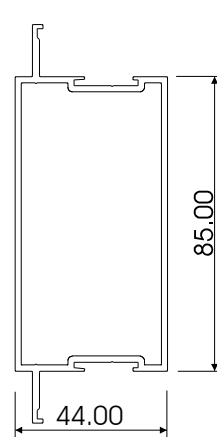

CLIP44 R4-SPECIAL
MID RAIL 85mm
W44089

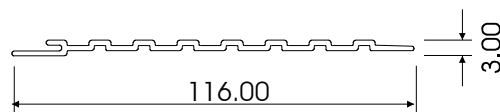

CLIP44 R19 SPECIAL CLADDING
W27934

CLIP44 SHOPFRONT SYSTEM
 OVERHEAD DOOR CLOSER DOOR
 PROFILE IDENTIFICATION
 - ALTERNATIVE PROFILES WITH WOOLPILE

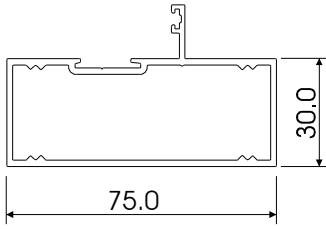

CLIP44 FLAT
 BACK WOOLPILE
 W55875

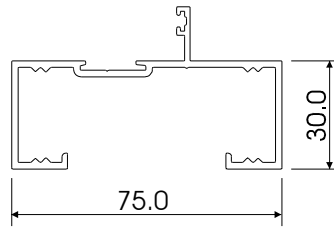

CLIP44 JAMB
 OPEN BACK WOOLPILE
 W32877

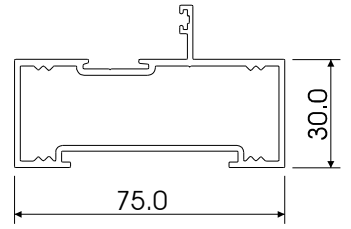

CLIP 44 RECESSED
 BACK WOOLPILE
 W55824

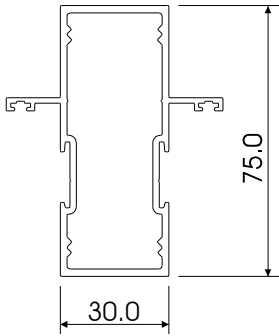

CLIP44 MULLION
 WOOLPILE
 W55891

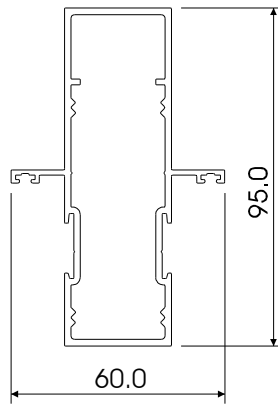

CLIP44 W95 MULLION
 WOOLPILE
 W56015

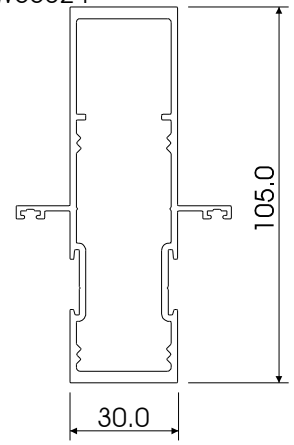

CLIP44 W105 MULLION
 WOOLPILE
 W56014

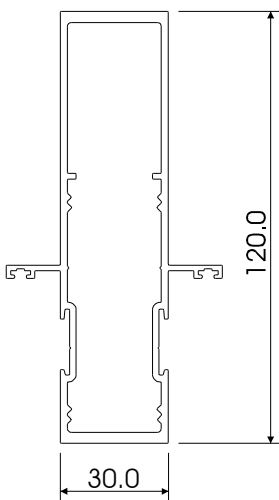

CLIP44 W150 MULLION
 WOOLPILE
 W55913

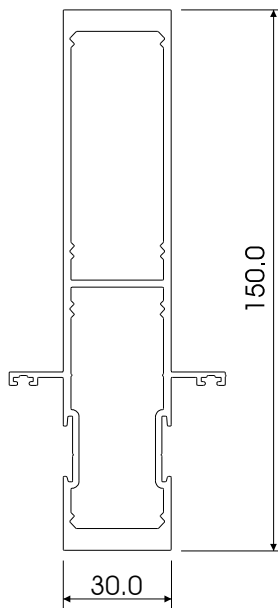

CLIP44 150mm MULLION
 WOOLPILE HEAVY DUTY
 W56012

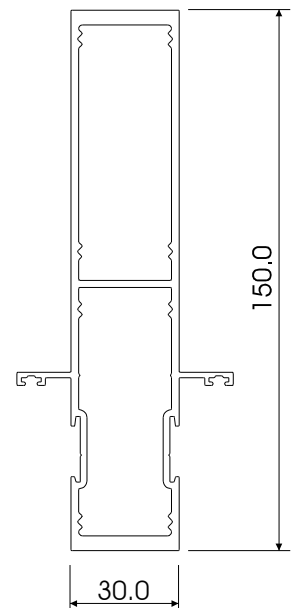

CLIP44 W150 MULLION
 WOOLPILE
 W56013

CLIP44 SHOPFRONT SYSTEM OVERHEAD DOOR CLOSER DOOR PROFILE IDENTIFICATION

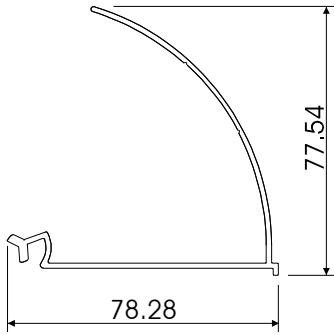

CLIP44 CORNER
MULLION 1
W28523

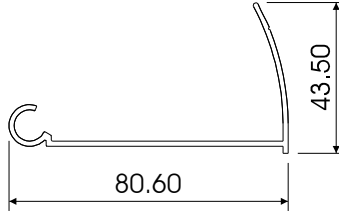

CLIP44 CORNER
MULLION 2
W28524

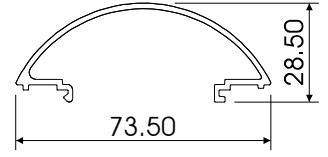

CLIP44 CURVED CLIP
HAND RAIL
W27038

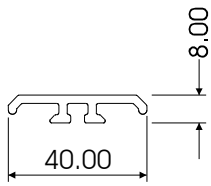

COLONIAL BAR
W29247

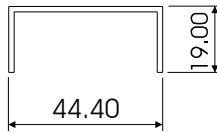

CLIP44 COMPENSATING
CHANNEL
W23224

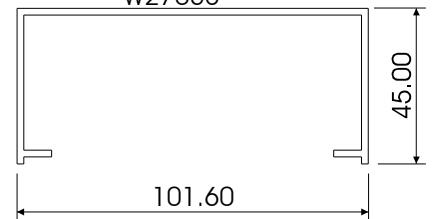

CLIP44 TRANSOM
W25028

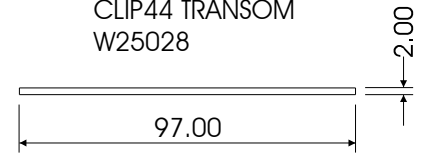

CLIP44 TRANSOM COVER
W25029

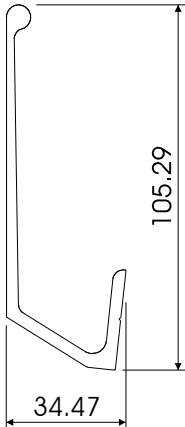

CLIP44 UNIVERSAL
DOOR HANDLE
W26464

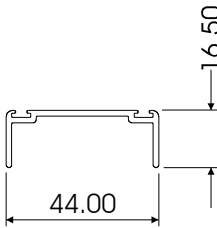

CLIP44 PIVOT DOOR
HEAD ADAPTOR
W26207

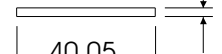

CLIP44 40mm
COVER PLATE
W25025

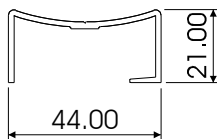

CLIP44 DOOR END
STYLE FOR PIVOT
W26155

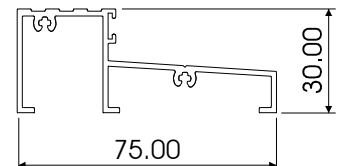

CLIP44 THRESHOLD
W30289

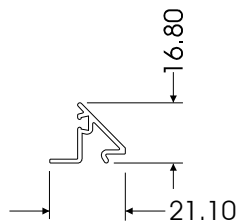

CLIP44 ANGLED
GLAZING BEAD
W30468

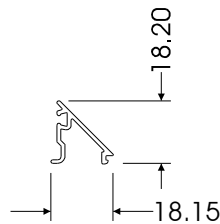

NEW CLIP44 ANGLED
GLAZING BEAD
W31142

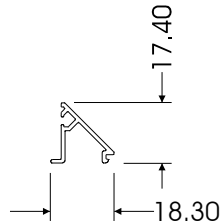

CLIP44 ANGLED
GLAZING BEAD
W14108

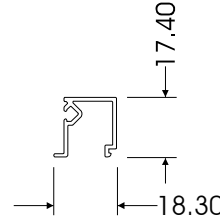

CLIP44 SQUARE
GLAZING BEAD
W14109

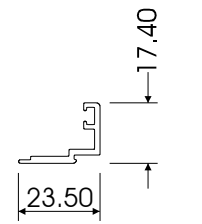

CLIP44 DOUBLE
GLAZING BEAD
W27882

CLIP44 SHOPFRONT SYSTEM OVERHEAD DOOR CLOSER DOOR PROFILE IDENTIFICATION

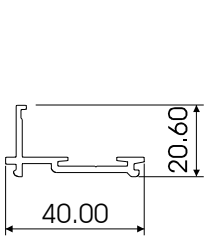

CLIP44 R4 FILLER
ADAPTOR
W26151

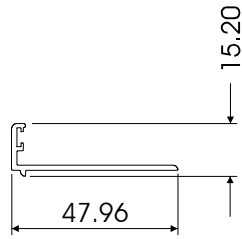

CLIP44 ASTRAGAL
WITH WOOLPILE
W27921

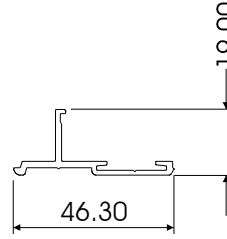

CLIP44 GLAZING
ADAPTOR
W28643

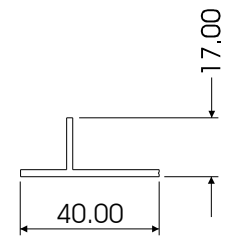

CLIP44 R4 SILL
END FILLER
W26093

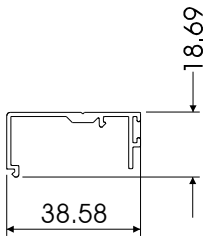

CLIP44 DOOR
ADAPTOR FOR W105
W29366

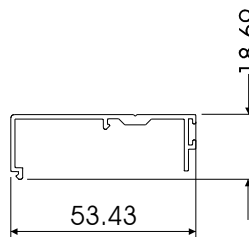

CLIP44 DOOR
ADAPTOR FOR W120
W29367

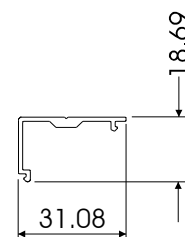

CLIP44 DOOR
ADAPTOR FOR W95
W29368

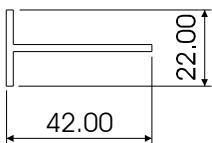

CLIP44 SLIDING DOOR
STOP ASTRAGAL
W25022

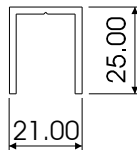

CLIP44 CHANNEL
SPIGOT
<W26152>

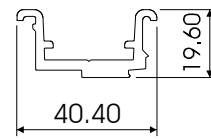

CLIP44 SPIGOT
<W26197>

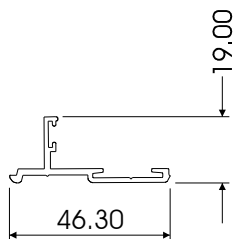

CLIP44 DOOR ADAPTOR
W26150

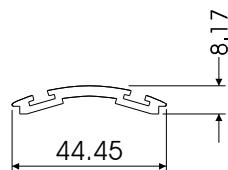

CLIP44 SILL ADAPTOR
W25048

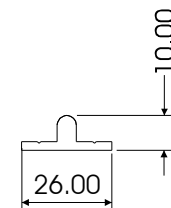

CLIP44 FLOOR
TRACK
<W26282>

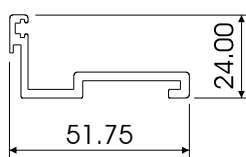

CLIP44 DRAINAGE
SILL ADAPTOR
W27522

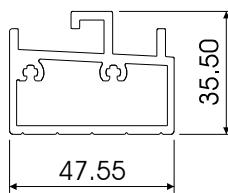

CLIP44 DRAINAGE SILL
W53448

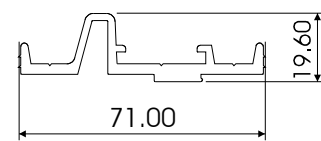

CLIP44 FRAME SPIGOT
<W26228>

CLIP44 SHOPFRONT SYSTEM OVERHEAD DOOR CLOSER DOOR INSERT HARDWARE IDENTIFICATION

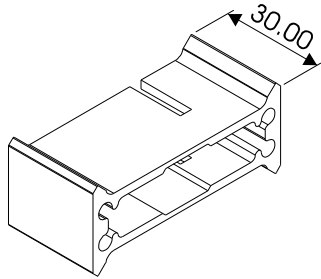

BOX SPIGOT 4 X S/PORT
W53752

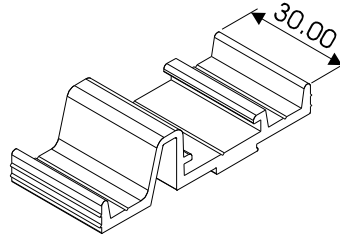

FRAME SPIGOT
<W26228>

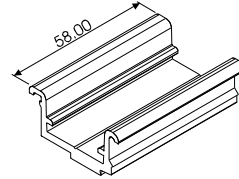
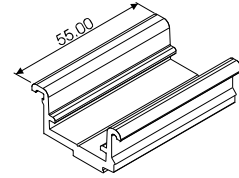

SPIGOT
<W26197>

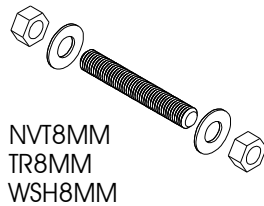

NVT8MM
TR8MM
WSH8MM

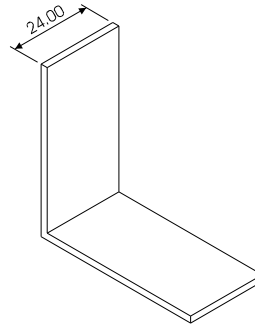

EQUAL ANGLE 50.0 x 50.0 x 2.0
W20423

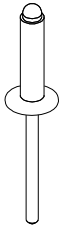

4x10 C/SUNK
RIVET
CSKR410



POP RIVET
4.8x12mm
CSKR4812



8x40 P/HEAD POSI
S/S SCREW
STPPS840

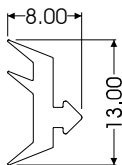

BUTTERFLY H13
CLPIV4FG

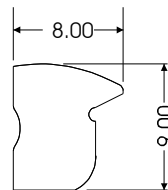

WEDGE H2
CLRIV65FG

CLIP44 SHOPFRONT SYSTEM OVERHEAD DOOR CLOSER DOOR INSERT HARDWARE IDENTIFICATION

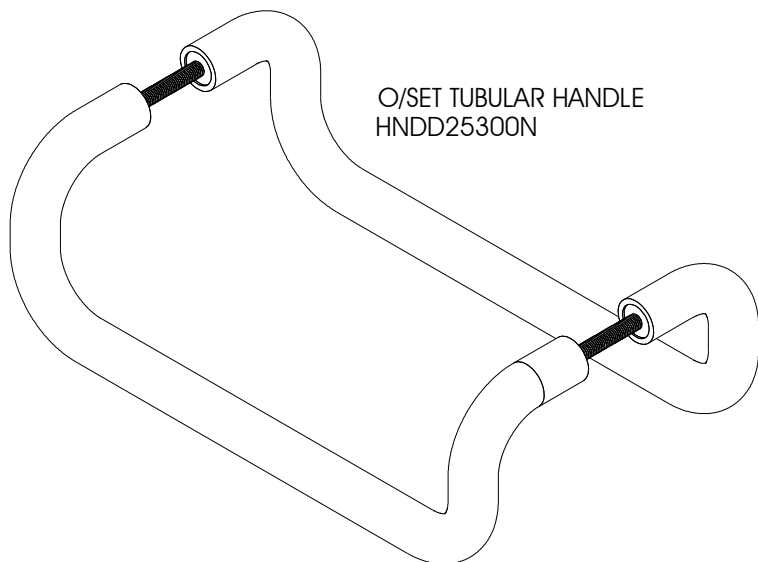

O/SET TUBULAR HANDLE
HNDD25300N

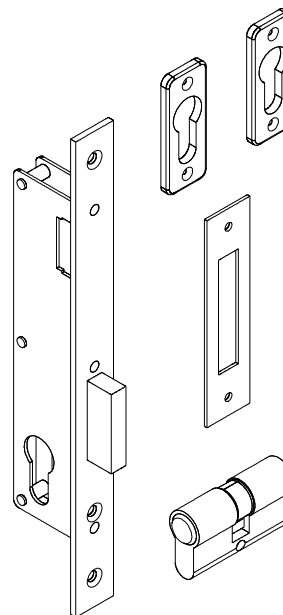

DEAD LOCK 25mm
CL44640/25

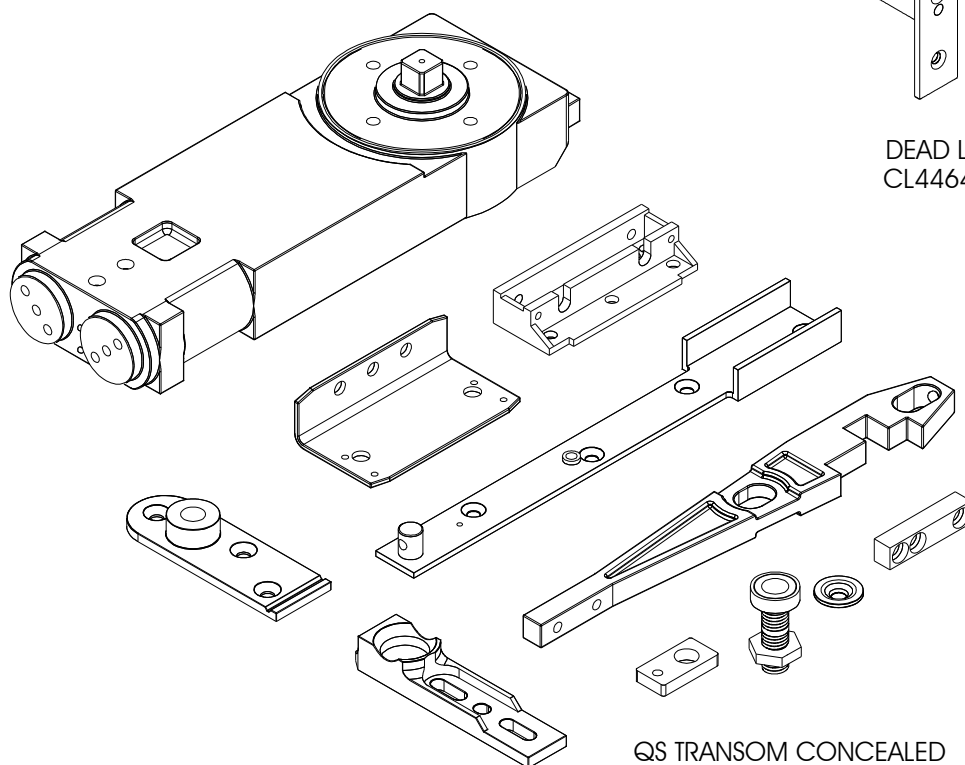

QS TRANSOM CONCEALED
DOOR CLOSER
CC900

CLIP44 SHOPFRONT SYSTEM OVERHEAD DOOR CLOSER DOOR BUTTERFLY GASKET AND WEDGE CODES



BUTTERFLY GASKET

●-B010

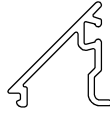

W31142 BEAD

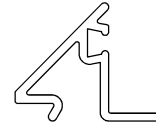

W30468 BEAD



●-W01G



●-W02B



●-W03R

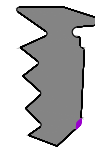

●-W05P

WEDGES

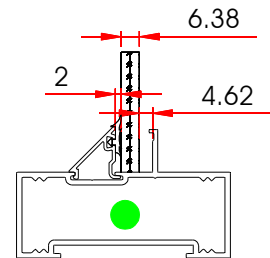
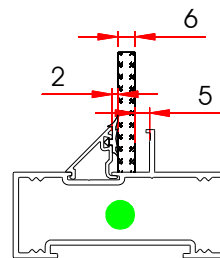
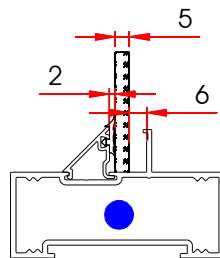
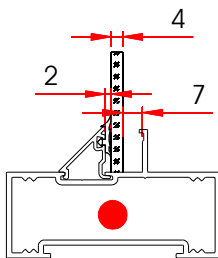

CLIP 44 WITH W31142 BEAD

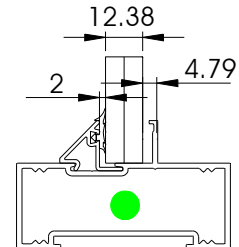
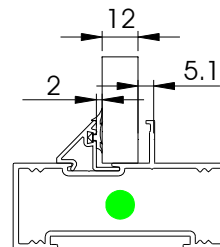
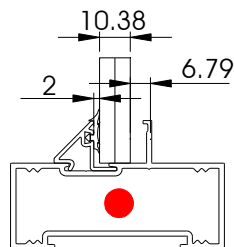
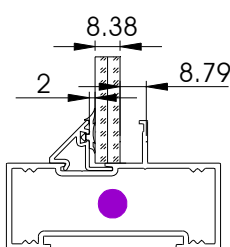

CLIP 44 WITH W30468 BEAD

CLIP44 SHOPFRONT SYSTEM OVERHEAD DOOR CLOSER DOOR LEAF SIZE LIMITATION GUIDE

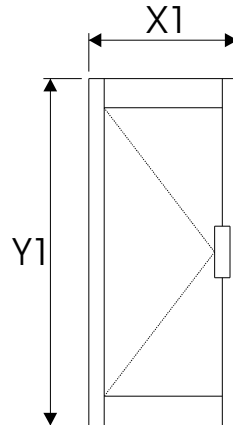

WHEN USING 45mm DOOR JAMB (EG. W44085 - R1 DOOR JAMB)

MAXIMUM DOOR LEAF WIDTH: X1 = 1000mm
MAXIMUM DOOR LEAF HEIGHT: Y1 = 2200mm

WHEN USING 60mm DOOR JAMB (EG. W53666 - R11W DOOR JAMB)

MAXIMUM DOOR LEAF WIDTH: X1 = 1100mm
MAXIMUM DOOR LEAF HEIGHT: Y1 = 2400mm

WHEN USING 90mm DOOR JAMB (EG. W53407 - R9W DOOR JAMB)

MAXIMUM DOOR LEAF WIDTH: X1 = 1200mm
MAXIMUM DOOR LEAF HEIGHT: Y1 = 2600mm

CLIP44 SHOPFRONT SYSTEM OVERHEAD DOOR CLOSER DOOR TYPICAL CONFIGURATIONS



SINGLE OVERHEAD DOOR
CLOSER DOOR

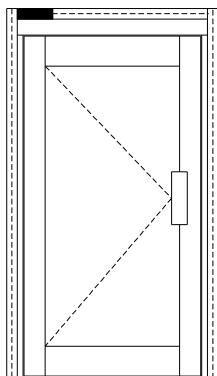

DOUBLE OVERHEAD DOOR
CLOSER DOOR

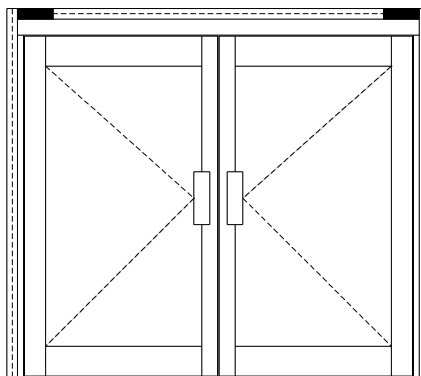

SINGLE OVERHEAD DOOR
CLOSER DOOR WITH MIDRAIL

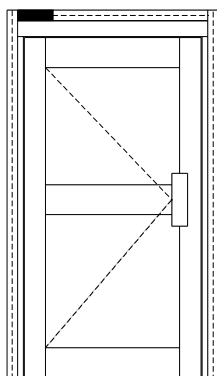

DOUBLE OVERHEAD DOOR
CLOSER DOOR WITH MIDRAIL

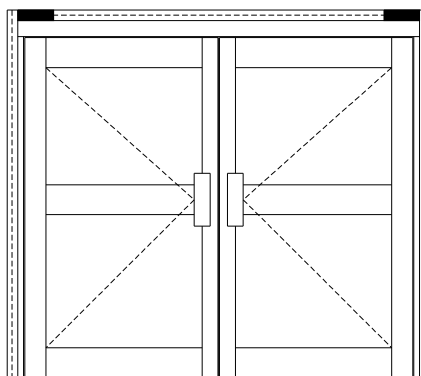

CLIP44 SHOPFRONT SYSTEM OVERHEAD DOOR CLOSER DOOR FIXING DETAILS

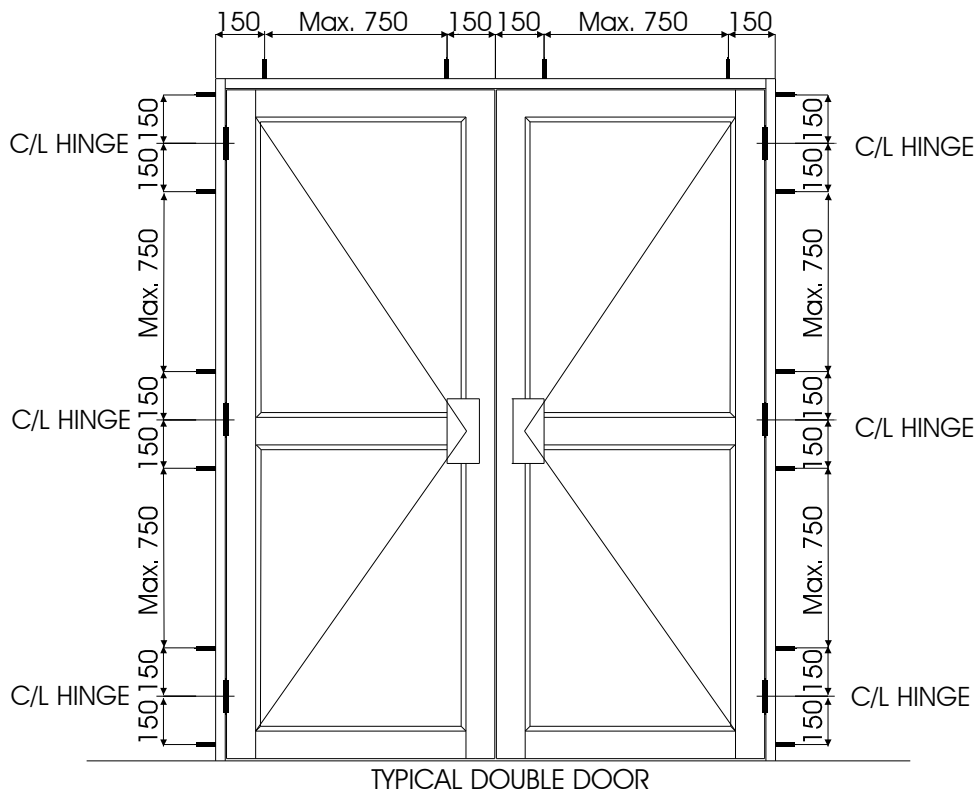
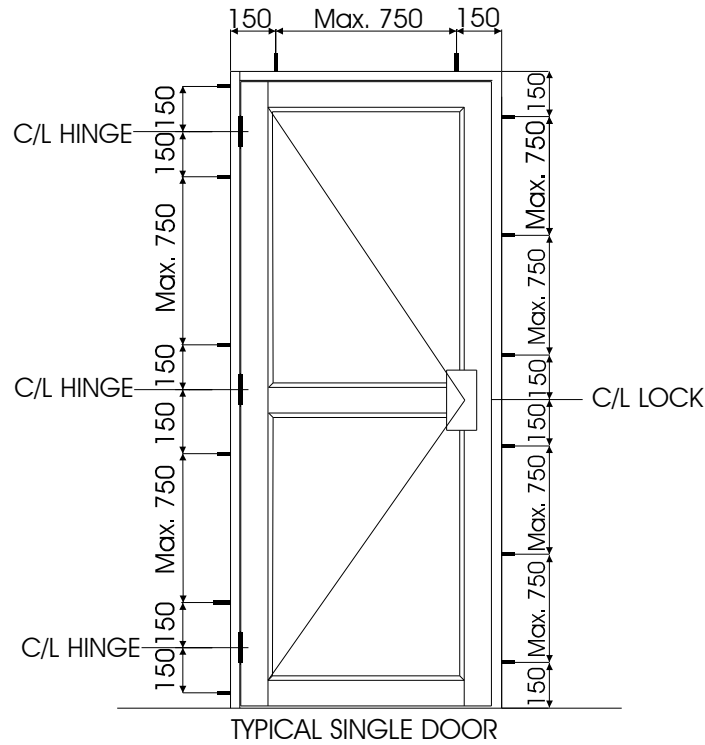

CLIP44 SHOPFRONT SYSTEM OVERHEAD DOOR CLOSER DOOR CROSS SECTIONAL DETAIL

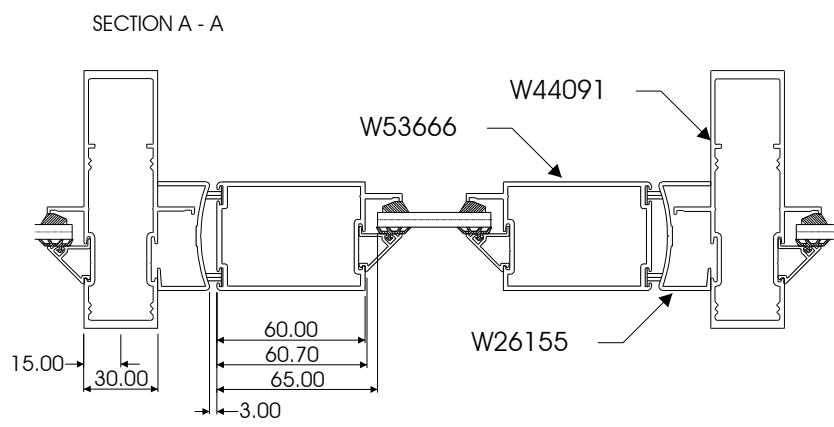
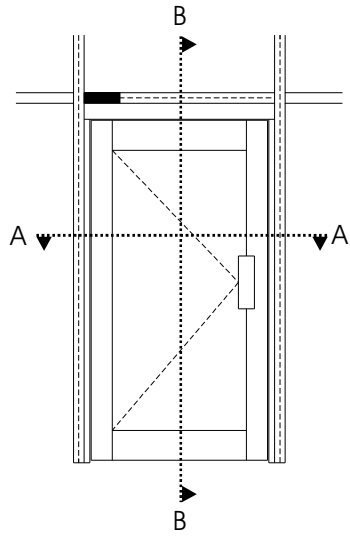
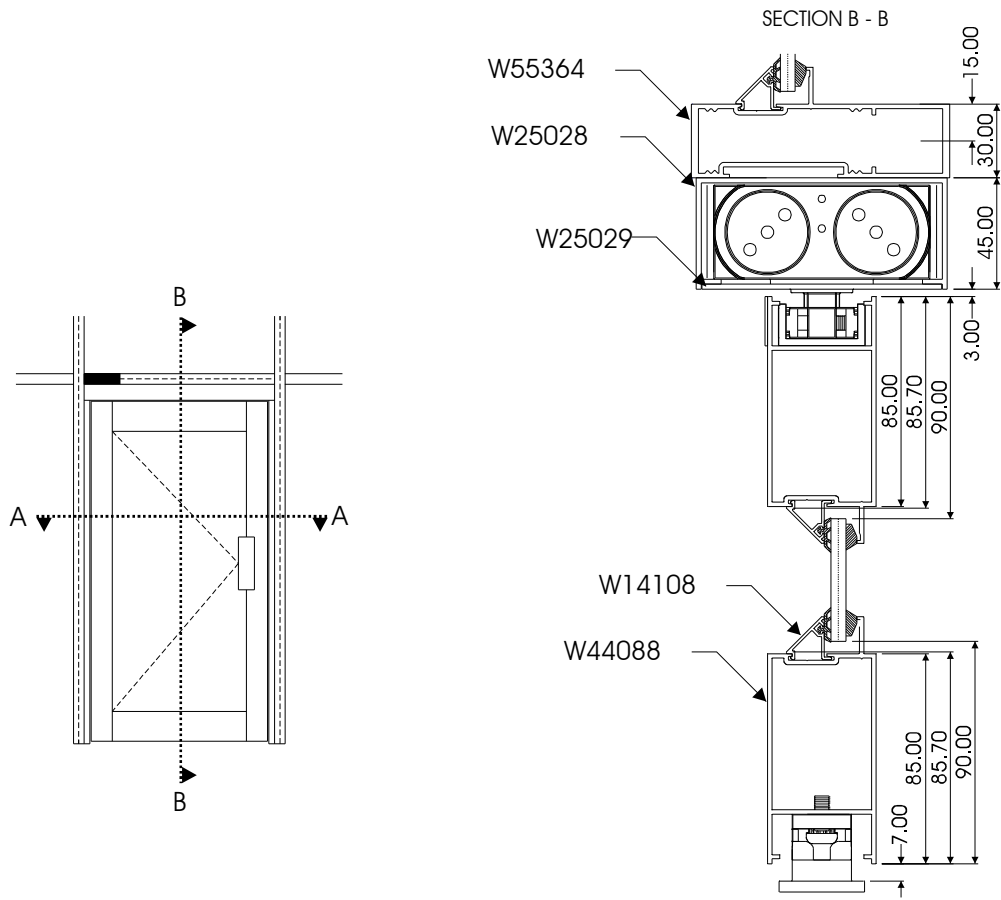

CLIP44 SHOPFRONT SYSTEM OVERHEAD DOOR CLOSER DOOR WITH MIDRAIL CROSS SECTIONAL DETAIL

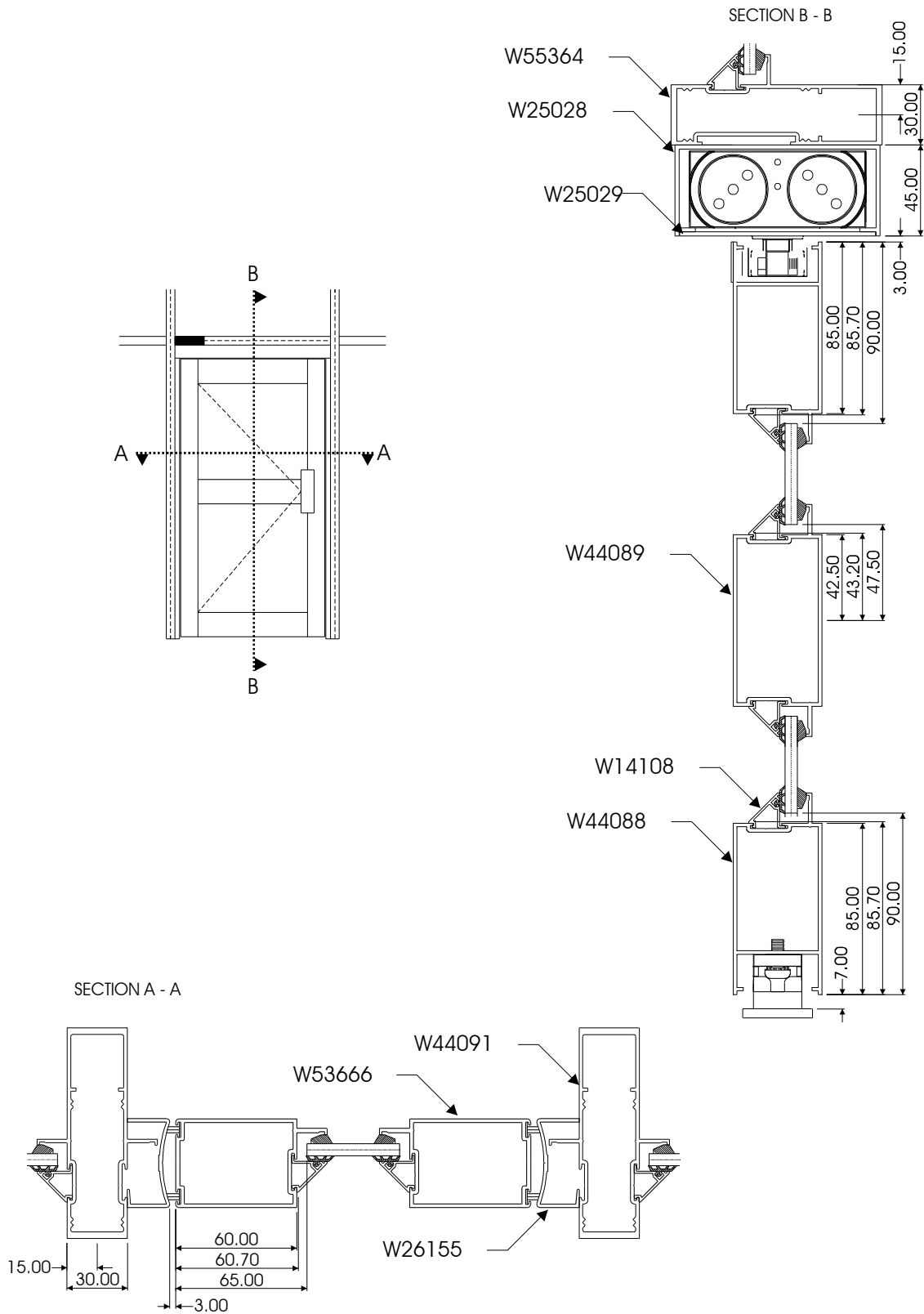

CLIP44 SHOPFRONT SYSTEM OVERHEAD DOOR CLOSER DOOR CROSS SECTIONAL DETAIL

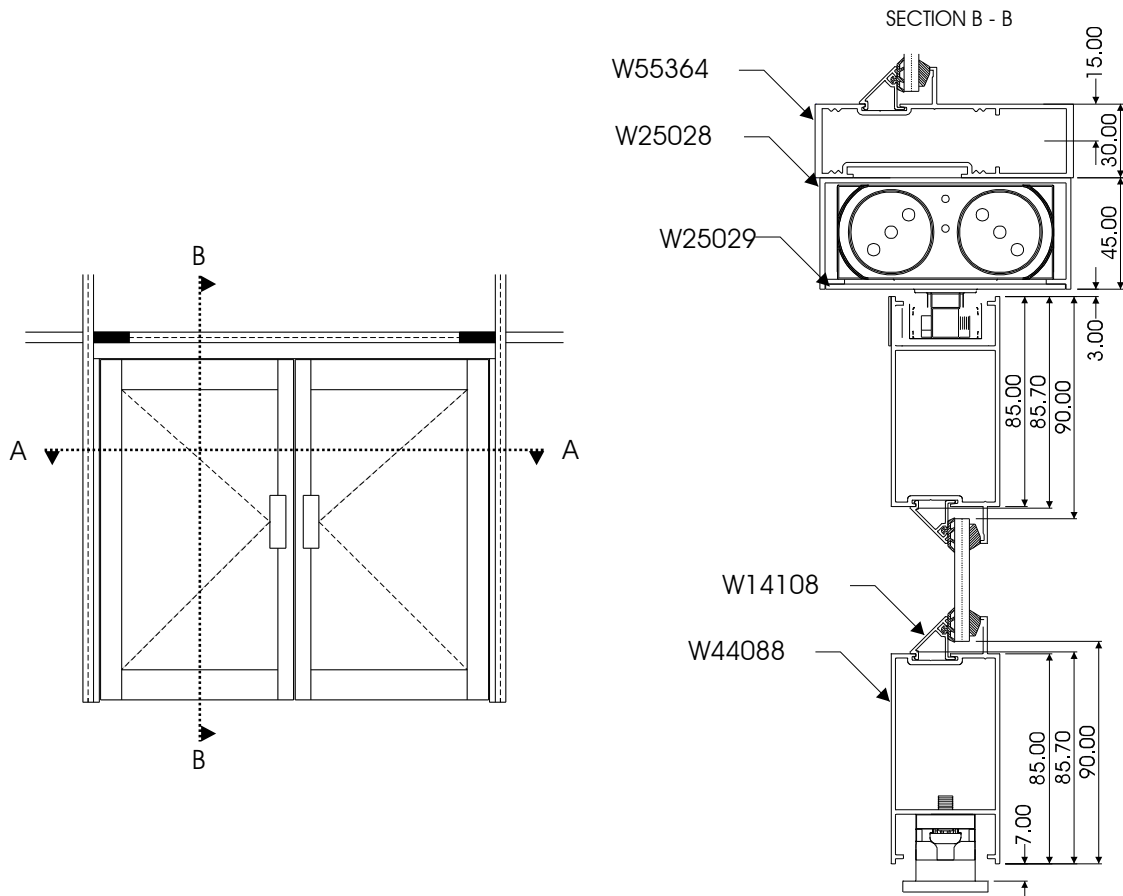

CLIP44 SHOPFRONT SYSTEM
 OVERHEAD DOOR CLOSER DOOR
 WITH MIDRAIL
 CROSS SECTIONAL DETAIL

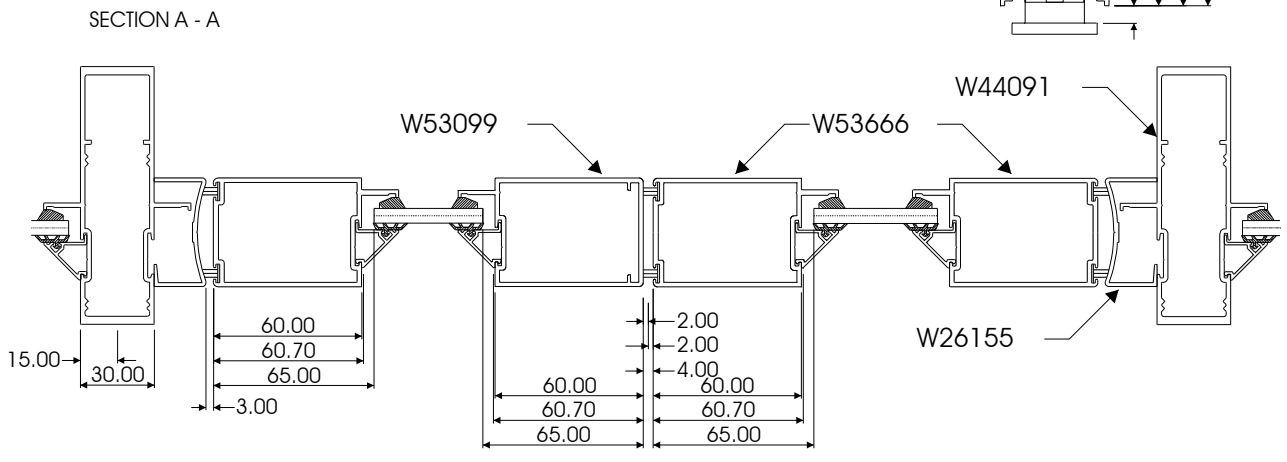
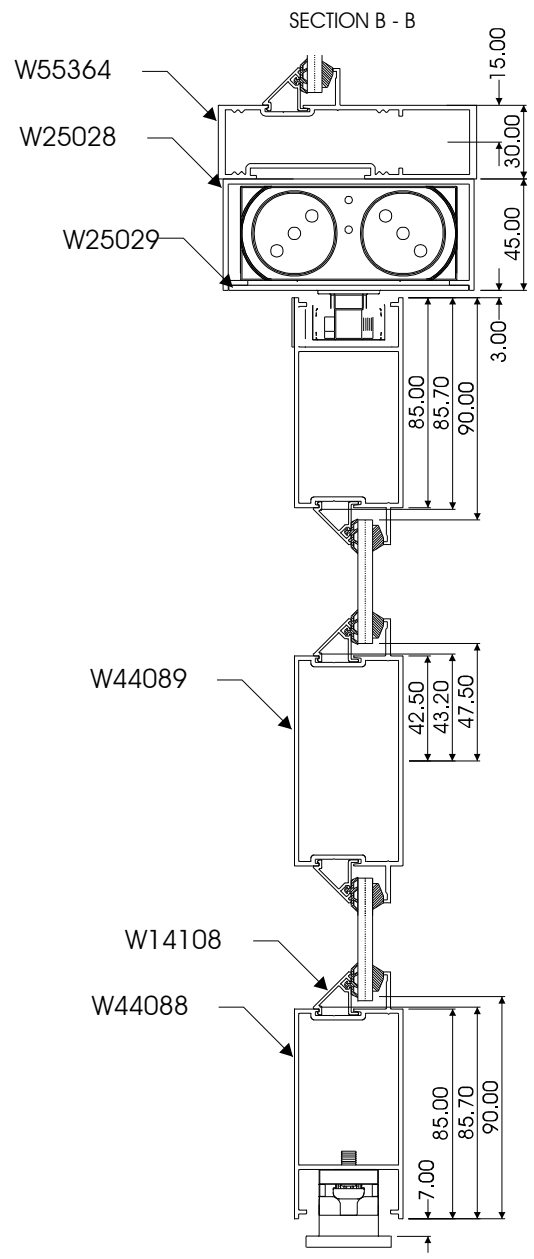
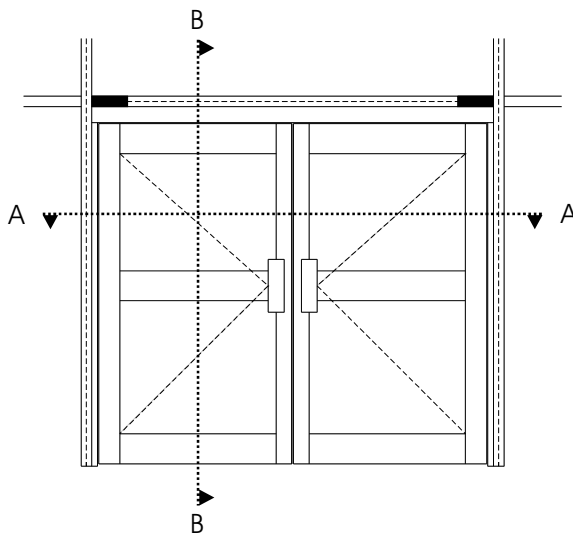

CLIP44 SHOPFRONT SYSTEM OVERHEAD DOOR CLOSER DOOR COMPONENT ASSEMBLY DETAIL

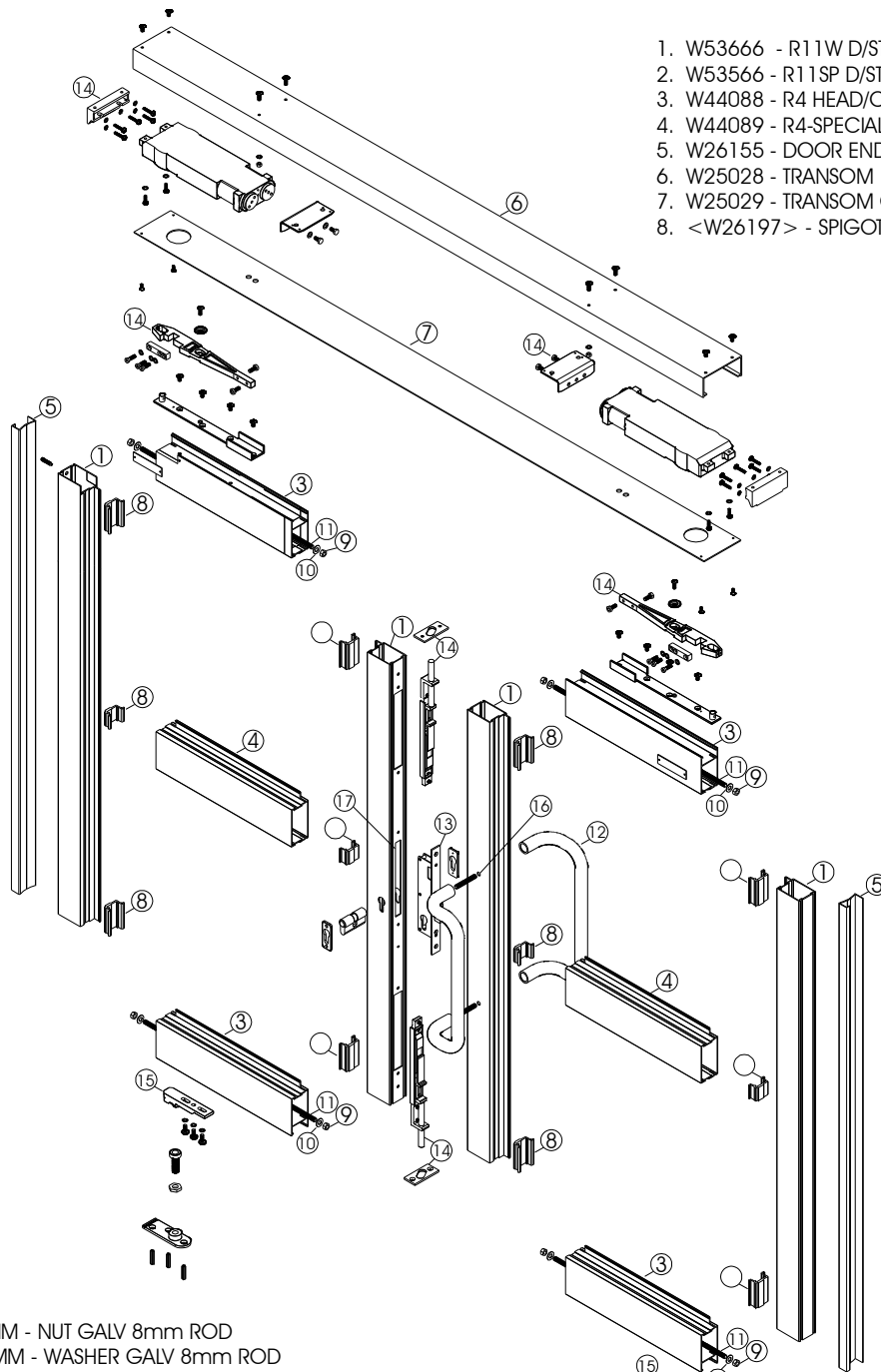

1. W53666 - R11W D/STILE 60mm W/PILE
2. W53566 - R11SP D/STILE 60mm
3. W44088 - R4 HEAD/CILL RAIL 85mm
4. W44089 - R4-SPECIAL MID RAIL 85mm
5. W26155 - DOOR END STYLE FOR PIVOT
6. W25028 - TRANSOM
7. W25029 - TRANSOM COVER
8. <W26197> - SPIGOT

9. NVT8MM - NUT GALV 8mm ROD
10. WSH8MM - WASHER GALV 8mm ROD
11. TR8MM - 8mm THREADED ROD GALV 3M
12. HNDD25300N - O/SET TUBULAR HANDLE
13. CL44640/25 - DEAD LOCK 25mm
14. FBNAT - FLUSH BOLT NAT ALUFAB 150X19mm
15. CC900 - QS TRANSOM CONCEALED DOOR CLOSER
16. HANDLE MACHINING DETAIL SEE PAGE D23
17. LOCK MACHINING DETAIL SEE PAGE D24
18. CC900 MACHINING DETAIL SEE PAGE D26 - D29

CLIP44 SHOPFRONT SYSTEM OVERHEAD DOOR CLOSER DOOR SILL MACHINING DETAIL TO SUIT ALL SILL COMBINATIONS



NOTE:
FOR SILL COMBINATIONS PLEASE
REFER TO PAGE D15 OF THIS MANUAL

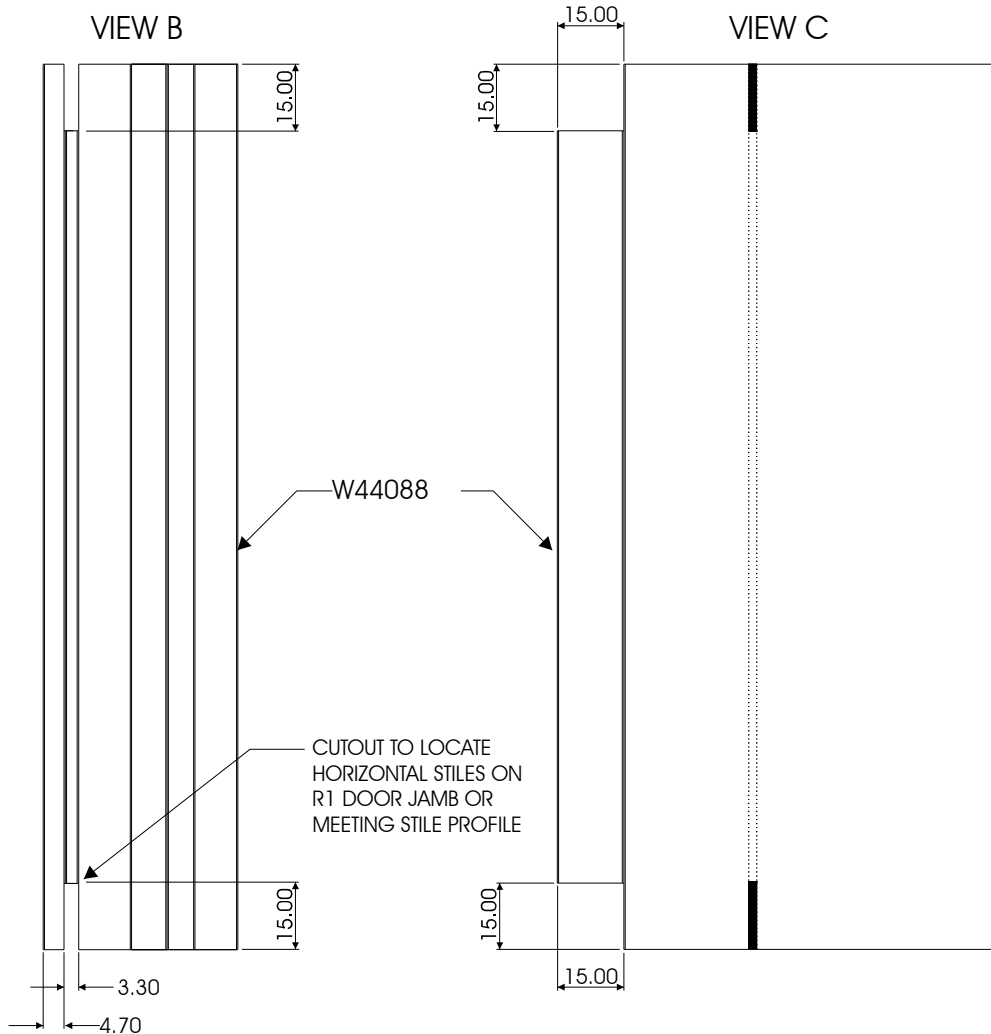
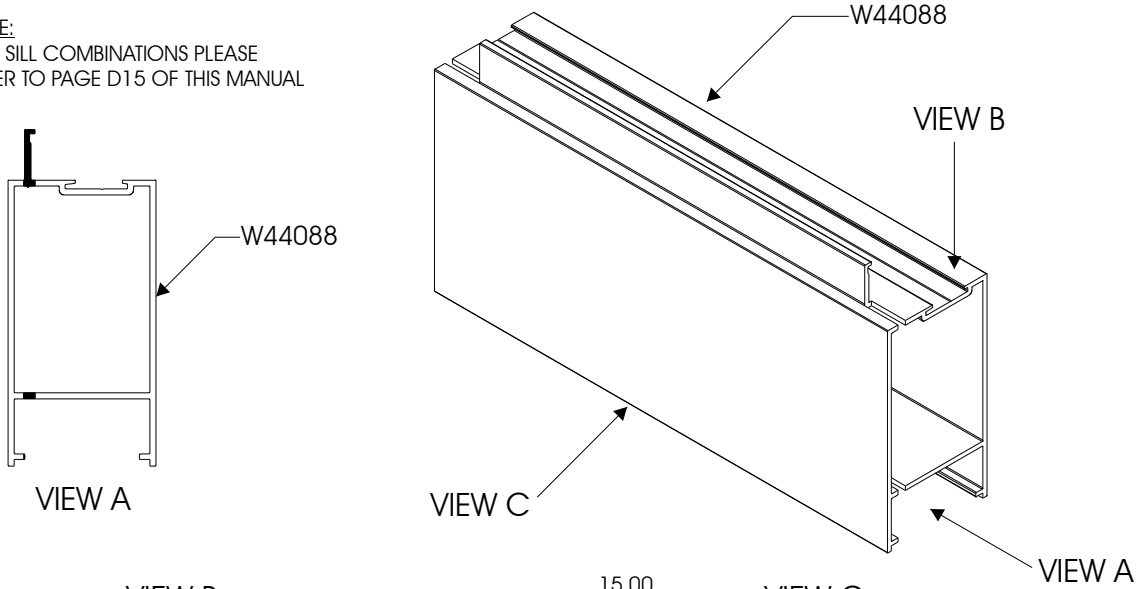

CLIP44 SHOPFRONT SYSTEM OVERHEAD DOOR CLOSER DOOR SILL COMBINATIONS

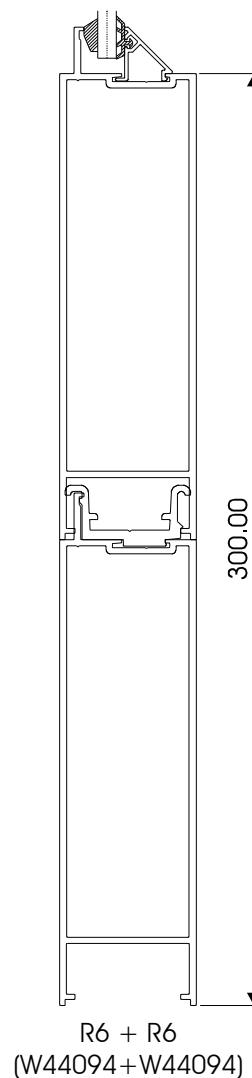
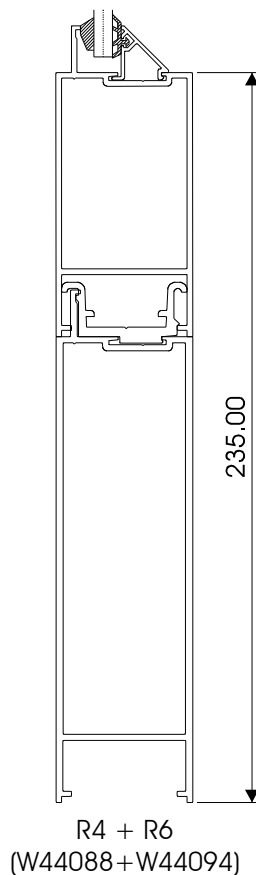
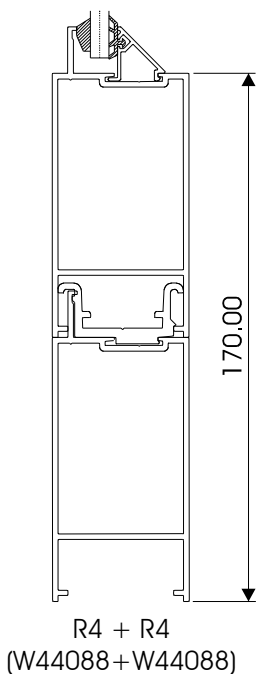
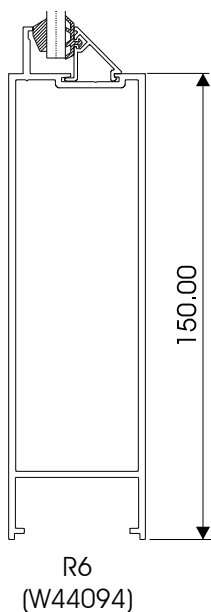
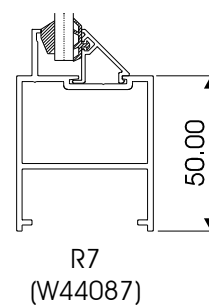
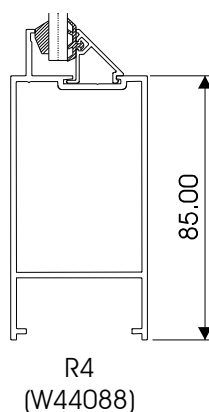
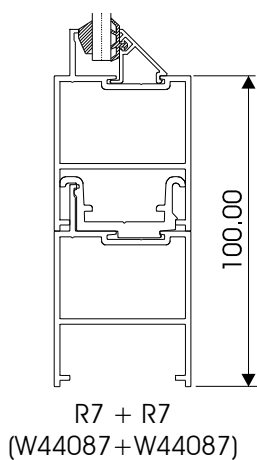
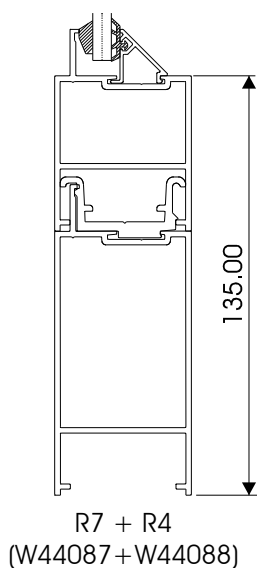

CLIP44 SHOPFRONT SYSTEM OVERHEAD DOOR CLOSER DOOR SILL FLOOR LEVEL DETAIL

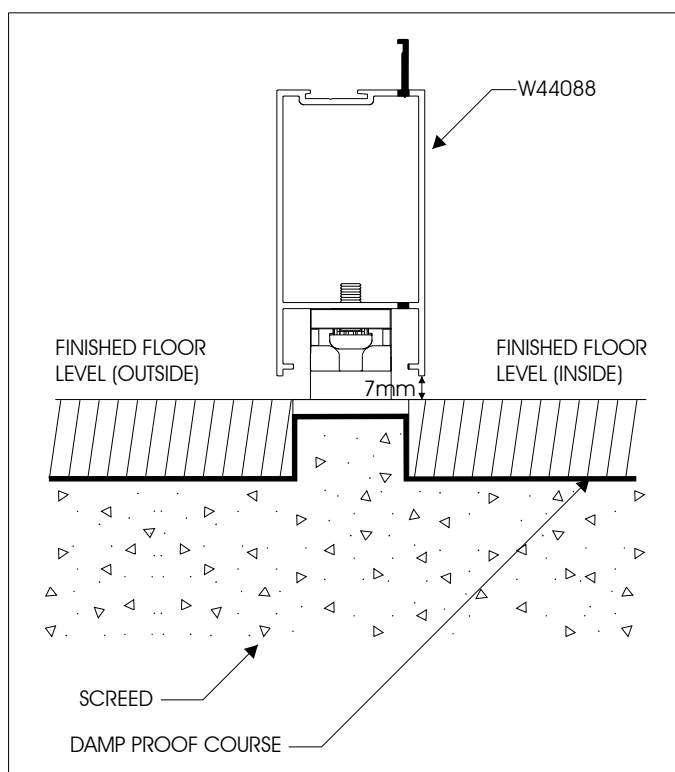
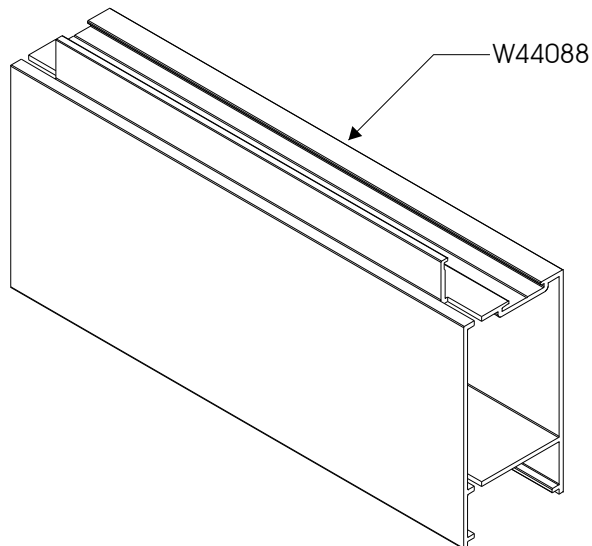

CLIP44 SHOPFRONT SYSTEM
 OVERHEAD DOOR CLOSER DOOR
 MIDRAIL MACHINING DETAIL
 TO SUIT ALL COMBINATIONS

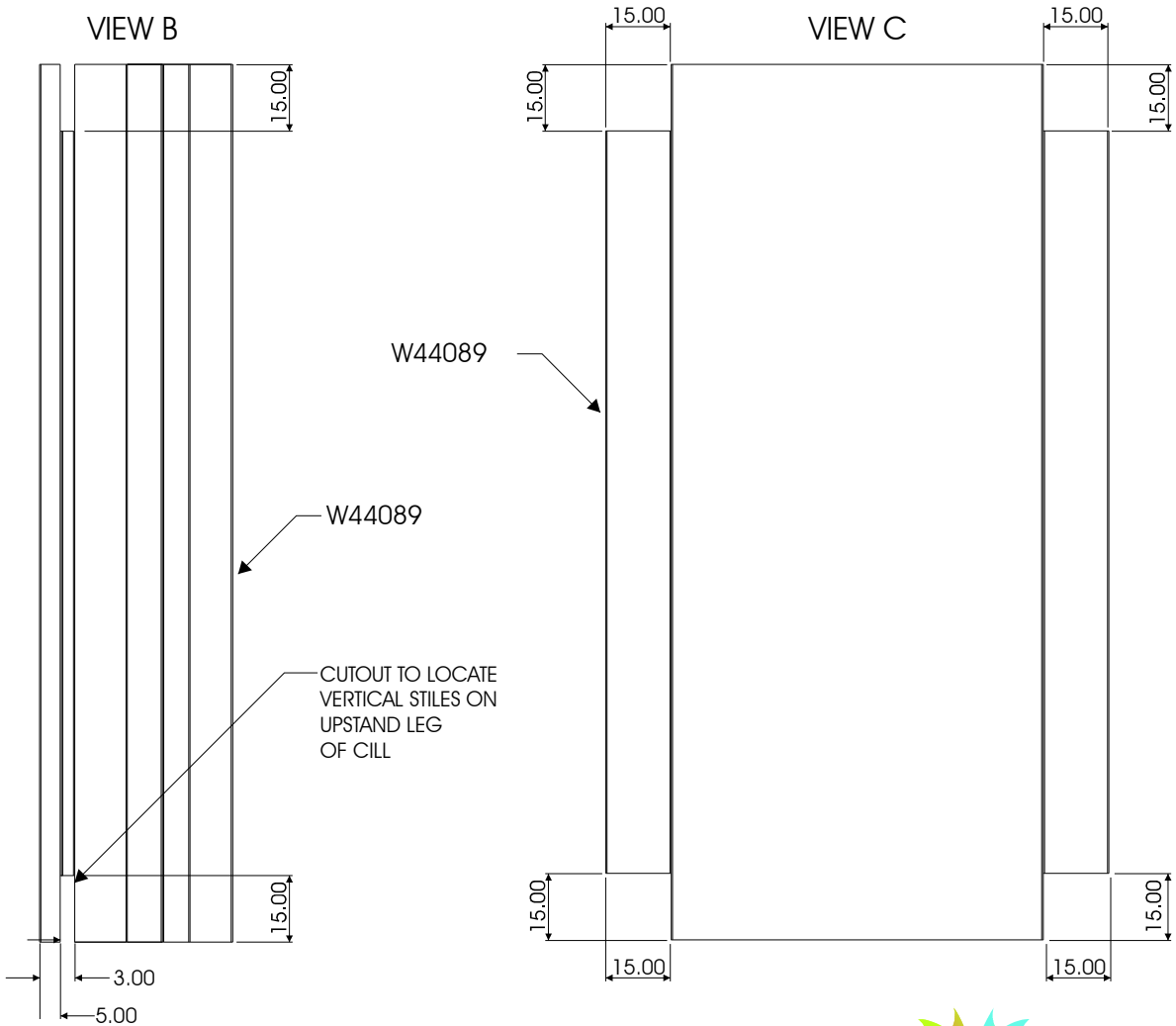
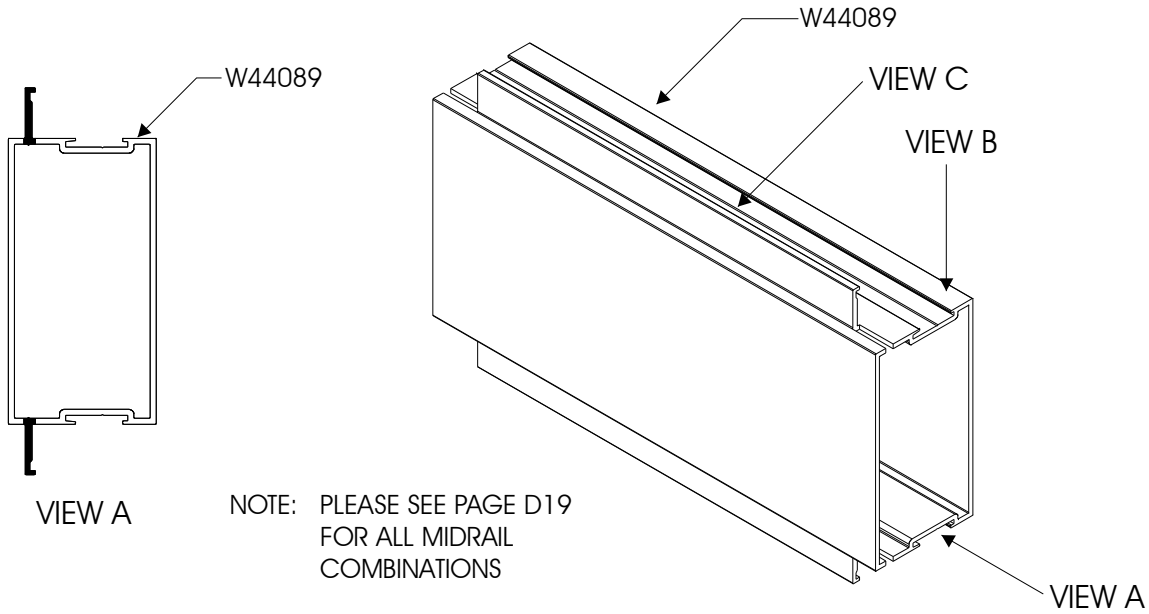

CLIP44 SHOPFRONT SYSTEM
 OVERHEAD DOOR CLOSER DOOR
 R4 FILLER ADAPTOR
 MACHINING DETAIL

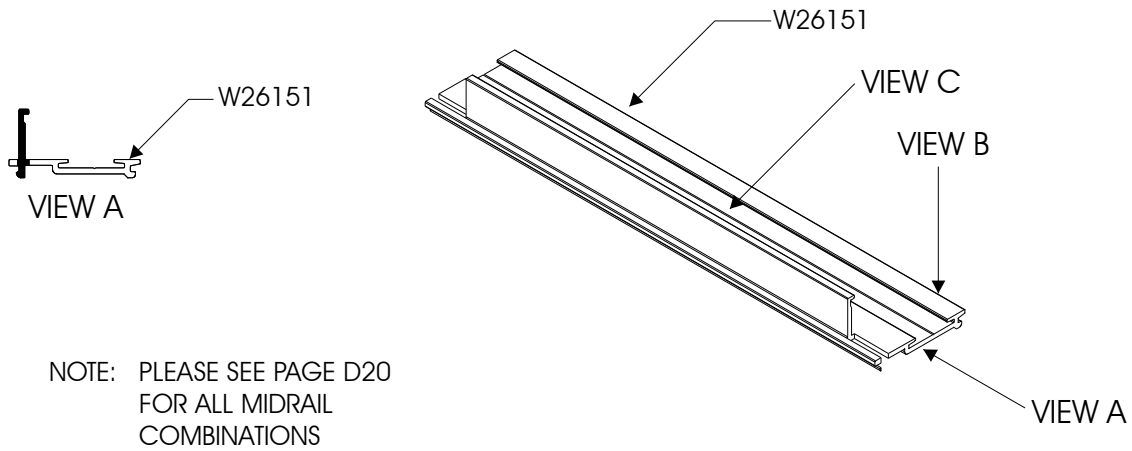

NOTE: PLEASE SEE PAGE D20
 FOR ALL MIDRAIL
 COMBINATIONS

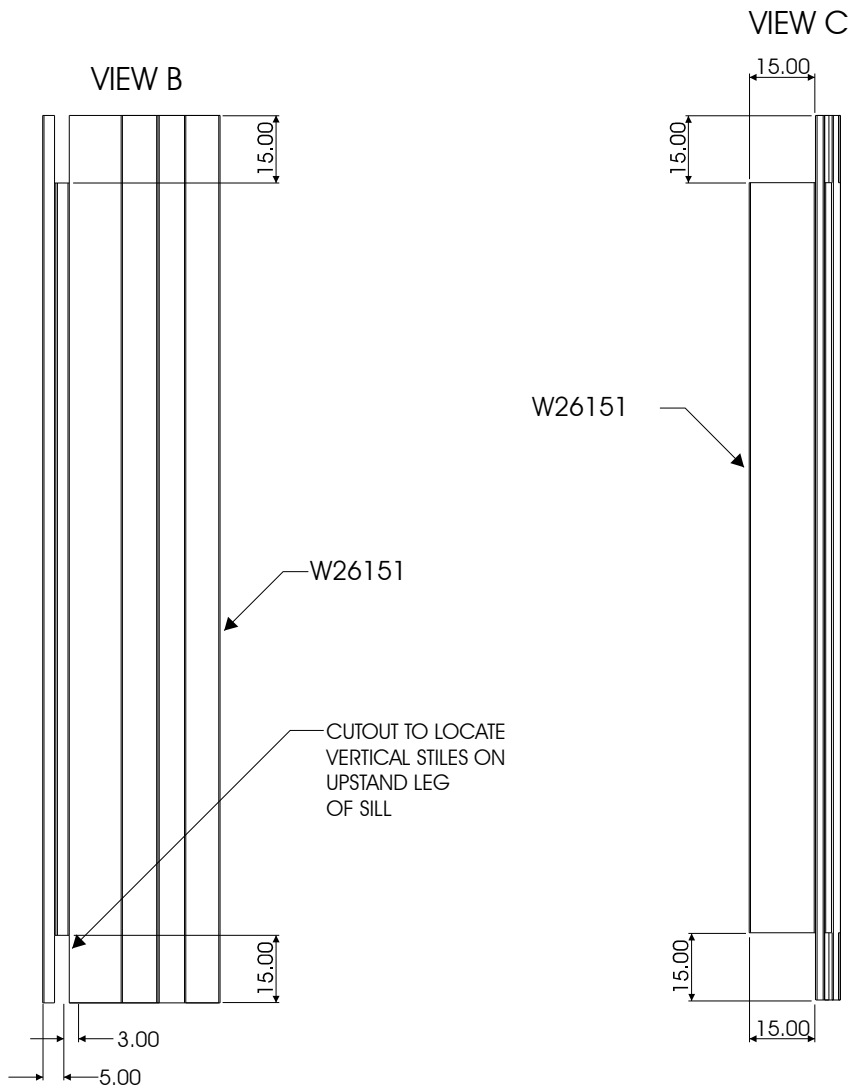

CLIP44 SHOPFRONT SYSTEM OVERHEAD DOOR CLOSER DOOR MIDRAIL COMBINATIONS

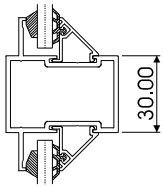

W44
(W53033)

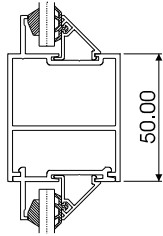

R7 + R4 FILLER
(W44087+W26151)

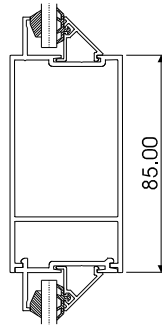

R4 + R4 FILLER
(W44088+W26151)

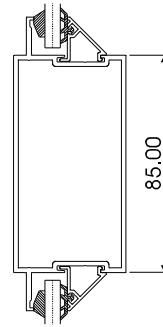

R4SP
(W44089)

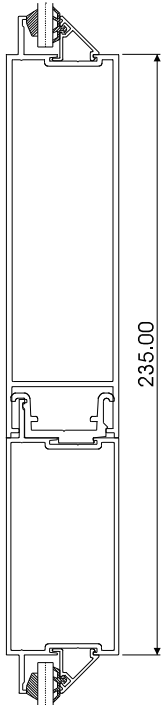

R6 + R4SP
(W44094+W44089)

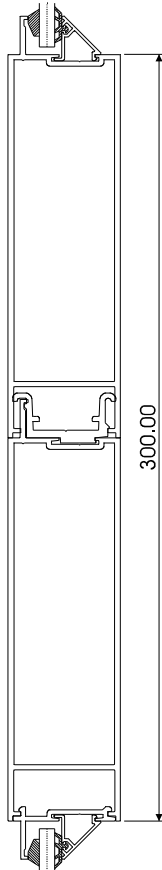

R6 + R6 + R4 FILLER
(W44094+W44094+W26151)

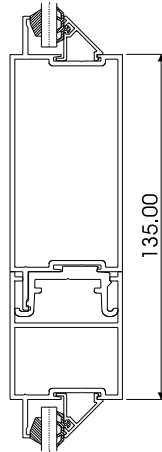

R7 + R4SP
(W44087+W44089)

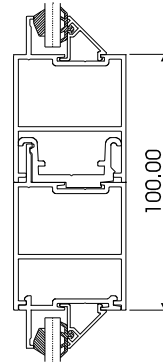

R7 + R7 + R4 FILLER
(W44087+W44087+W26151)

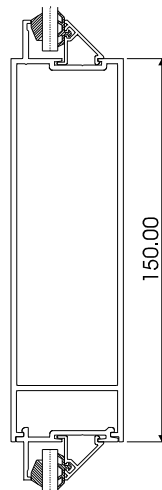

R6 + R4 FILLER
(W44094+W26151)

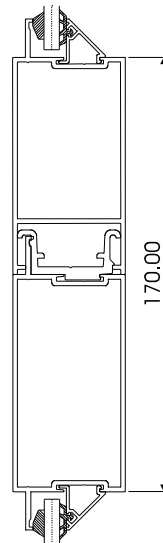

R4 + R4SP
(W44088+W44089)

CLIP44 SHOPFRONT SYSTEM
OVERHEAD DOOR CLOSER DOOR
SPIGOT MACHINING DETAIL



<W26197>

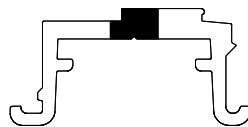
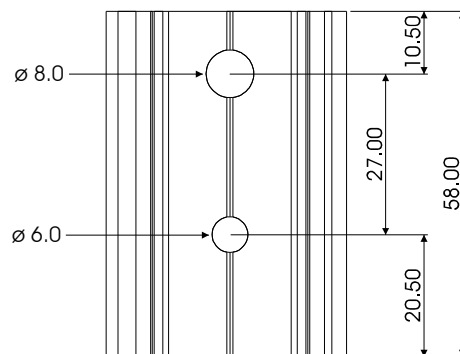
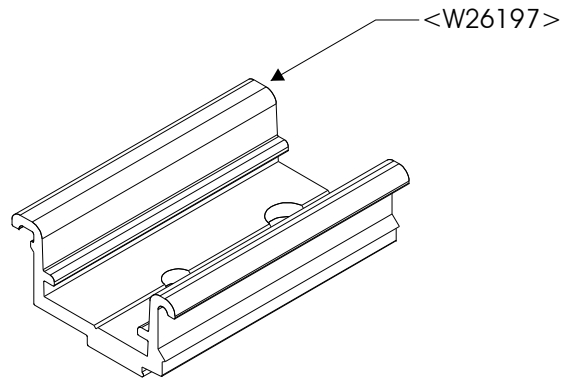

CLIP44 SHOPFRONT SYSTEM
 OVERHEAD DOOR CLOSER DOOR
 DOOR STILE MACHINING DETAIL

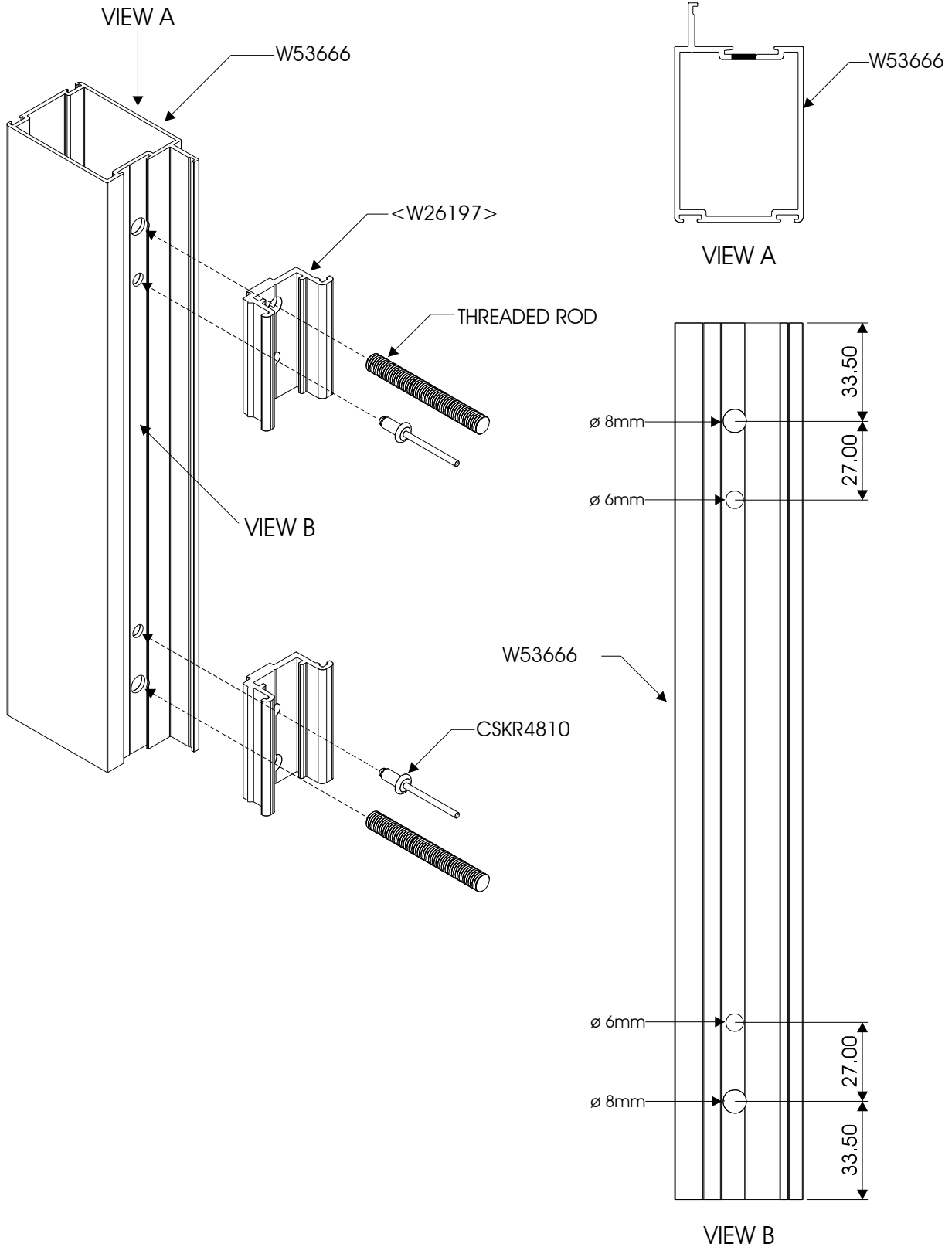

CLIP44 SHOPFRONT SYSTEM OVERHEAD DOOR CLOSER DOOR ROD & SPIGOT ASSEMBLY DETAIL

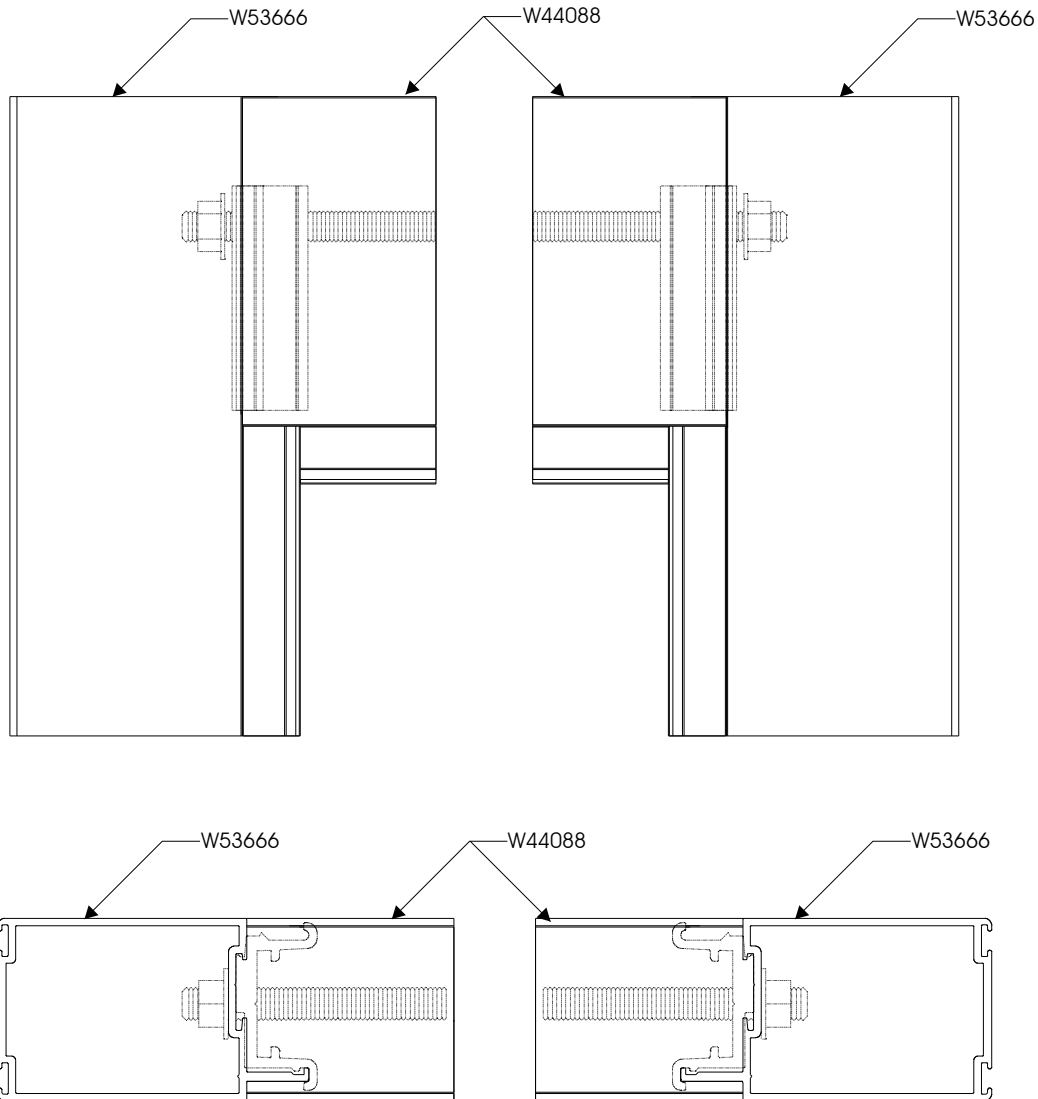

DETAIL TYPICAL TO HEAD AND SILL OF HINGED DOOR

1. ATTACH SPIGOTS TO STILES WITH NO 8 FIXING SCREWS (STPPS830)
2. FASTEN STILES TO TOP AND BOTTOM RAILS WITH NUTS (NVT8MM) AND THREADED RODS (TR8MM), USE WASHERS (WSH8MM).
3. ENSURE ALL MATING JOINTS ARE BEDDED IN SEALANT BEFORE ASSEMBLY.

CLIP44 SHOPFRONT SYSTEM
 OVERHEAD DOOR CLOSER DOOR
 HANDLE MACHINING DETAIL
 HNDD25300N

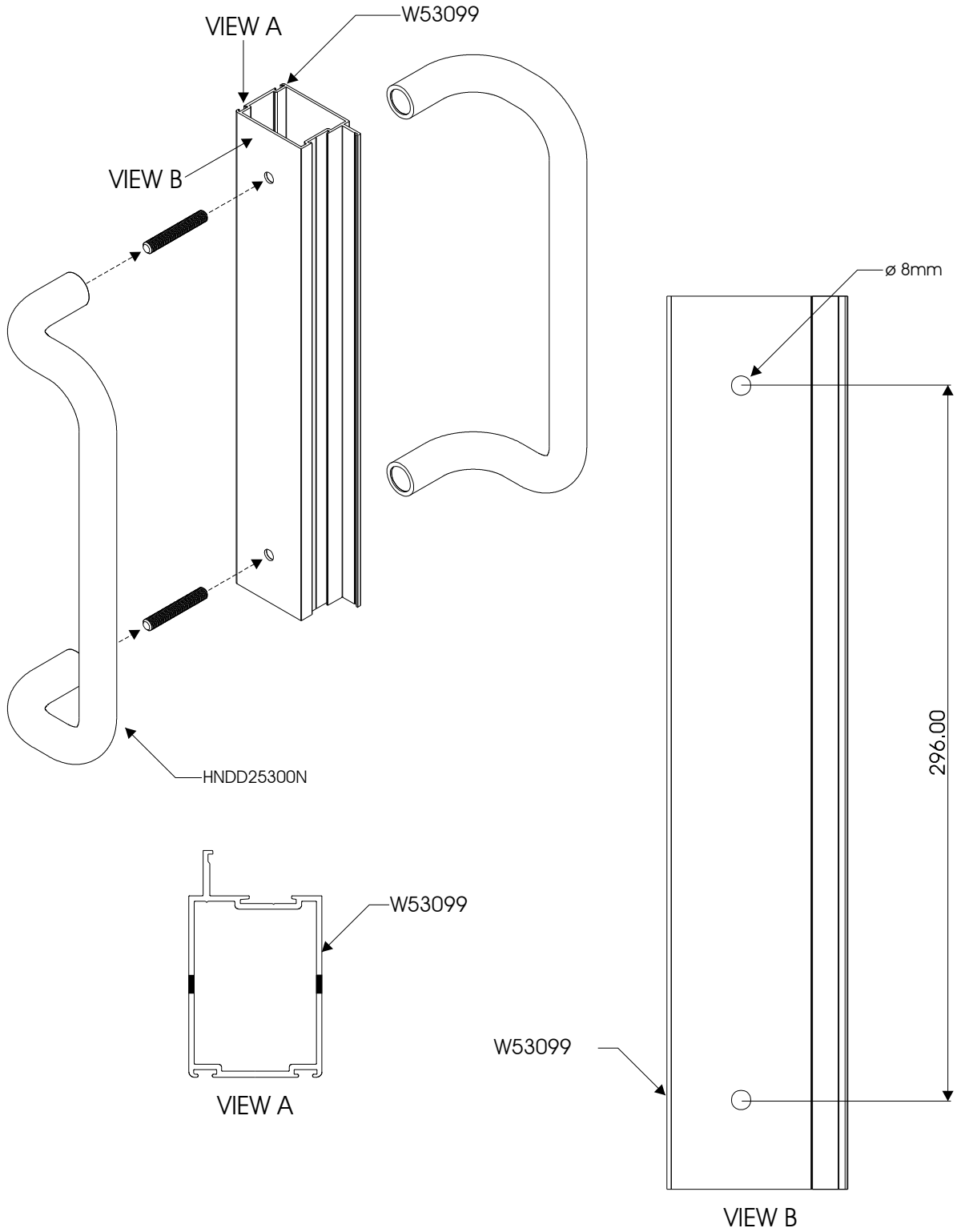

CLIP44 SHOPFRONT SYSTEM
 OVERHEAD DOOR CLOSER DOOR
 MEETING STILE MACHINING DETAIL
 FOR LOCK CL44640/25

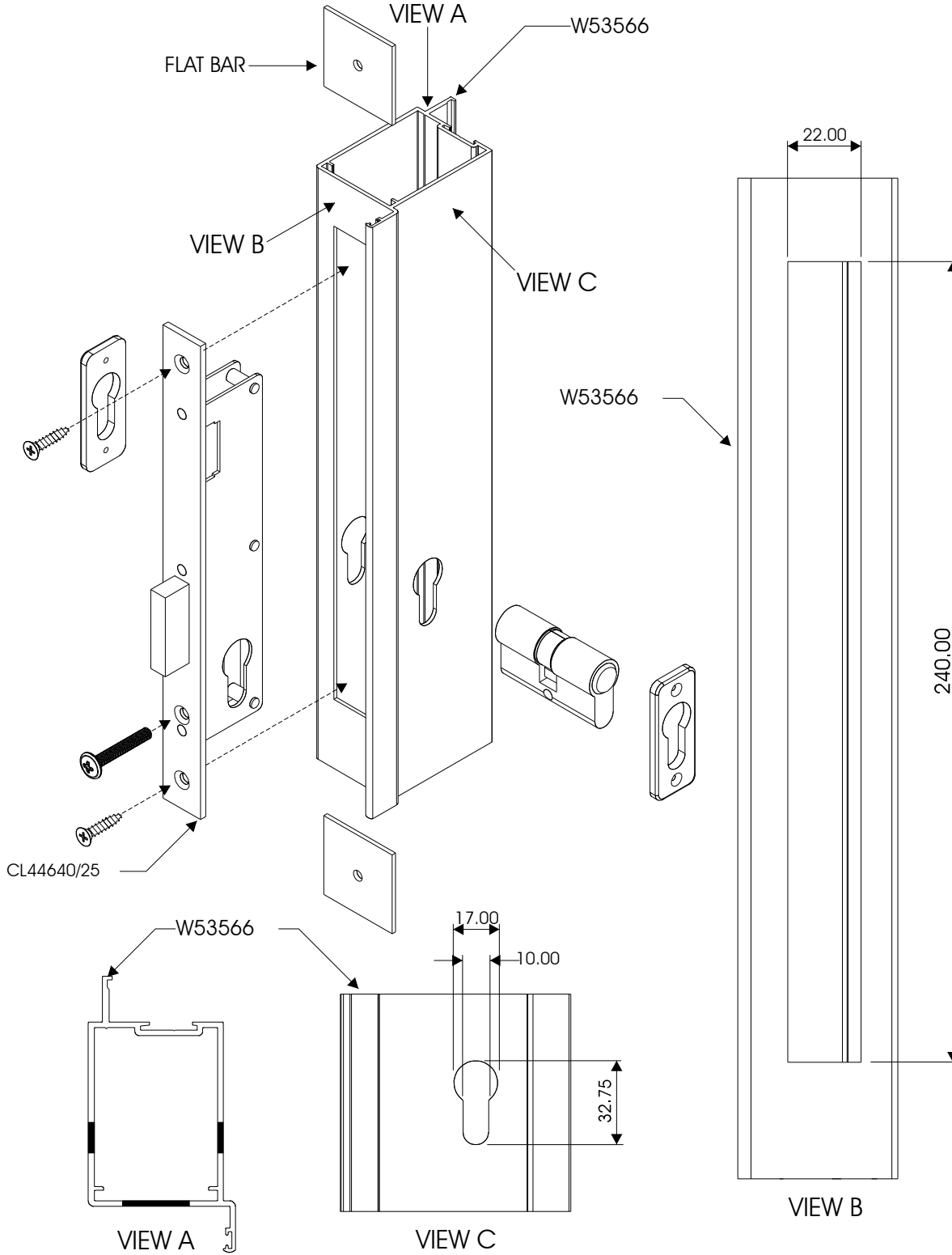

CLIP44 SHOPFRONT SYSTEM
 OVERHEAD DOOR CLOSER DOOR
 TRANSOM & TRANSOM COVER
 MACHINING DETAIL
 CC900

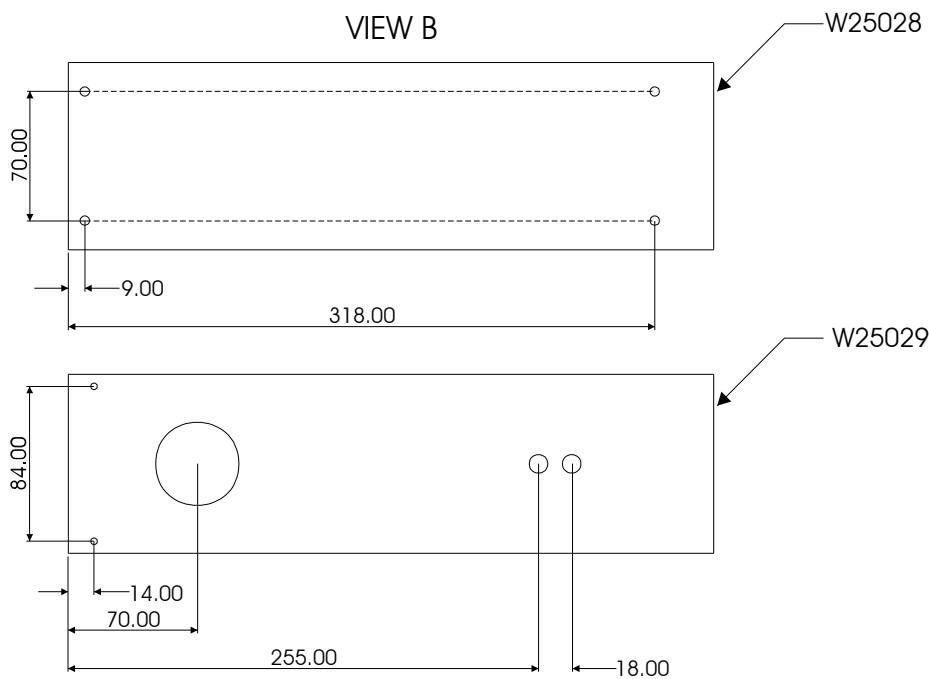
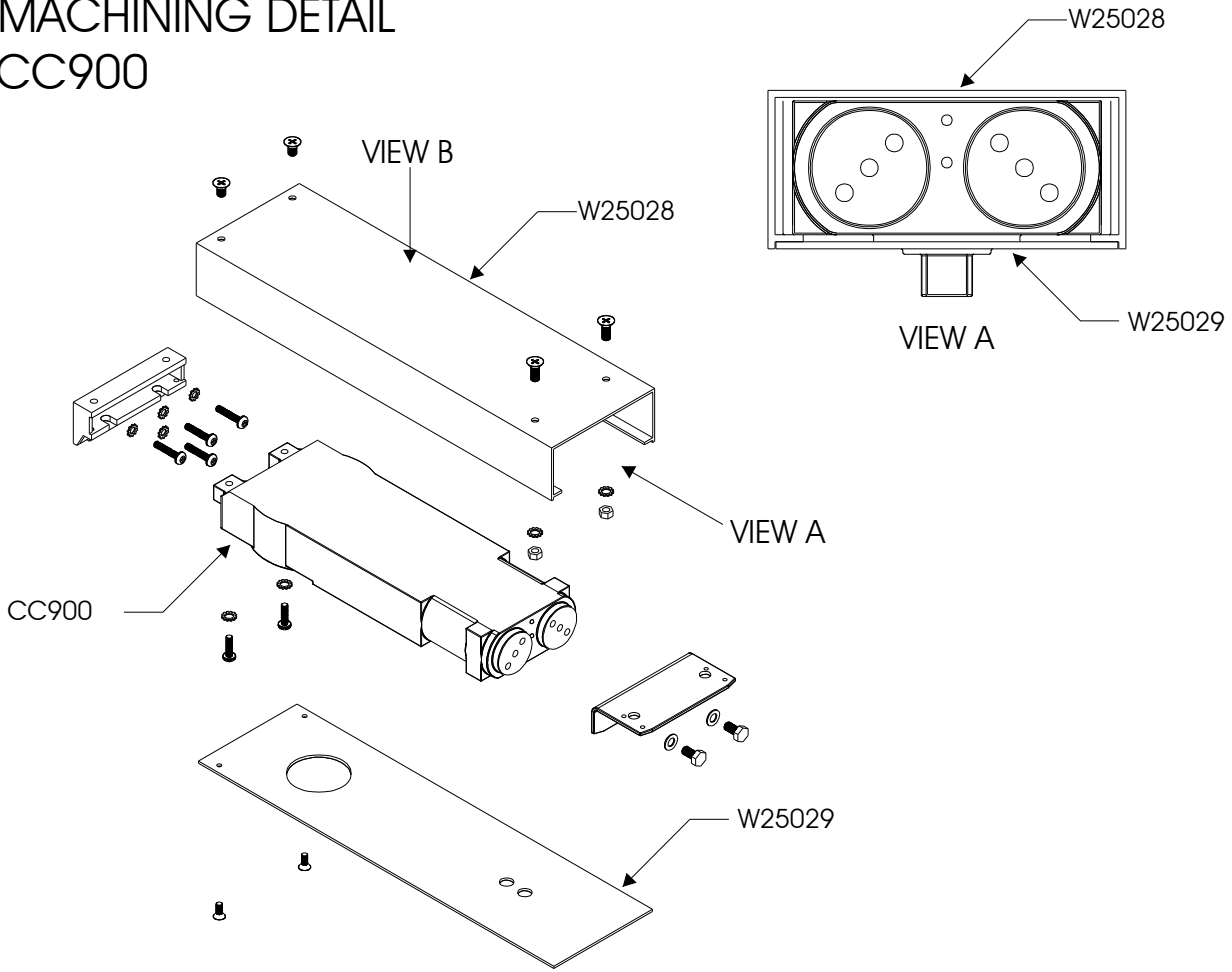

CLIP44 SHOPFRONT SYSTEM
 OVERHEAD DOOR CLOSER DOOR
 JAMB MACHINING DETAIL
 CC900

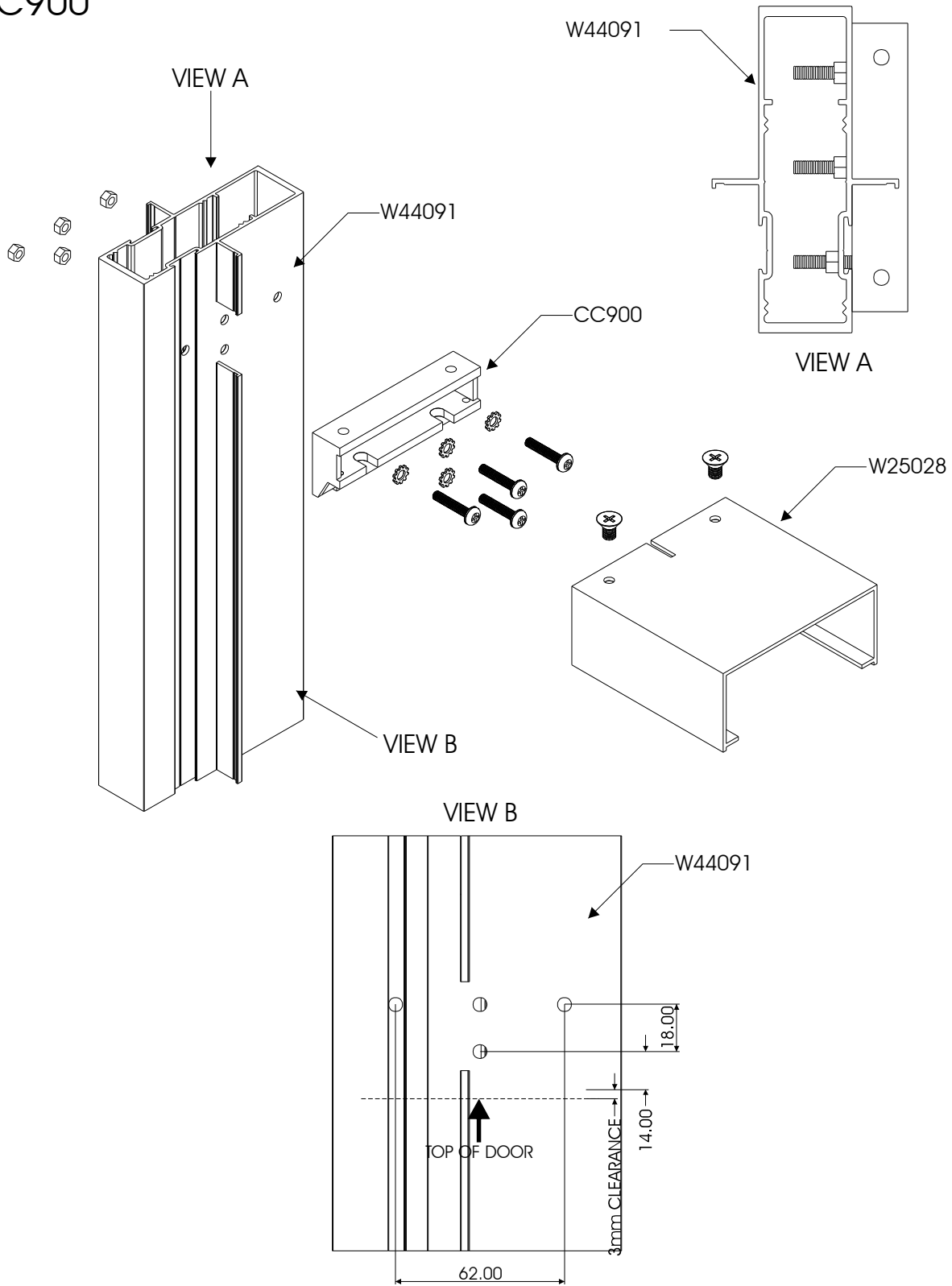

CLIP44 SHOPFRONT SYSTEM OVERHEAD DOOR CLOSER DOOR HEAD MACHINING DETAIL CC900

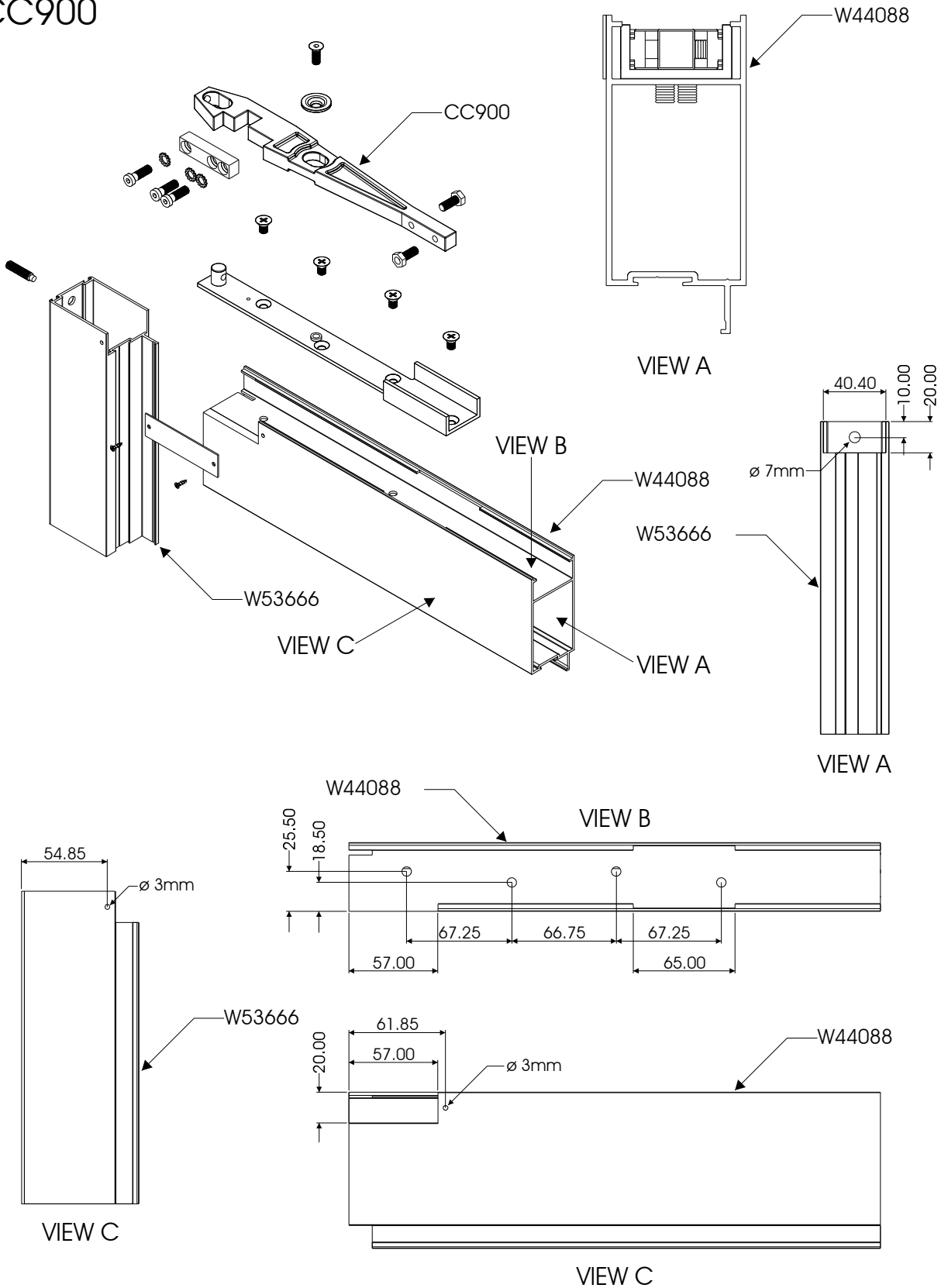

CLIP44 SHOPFRONT SYSTEM
 OVERHEAD DOOR CLOSER DOOR
 SILL MACHINING DETAIL
 CC900

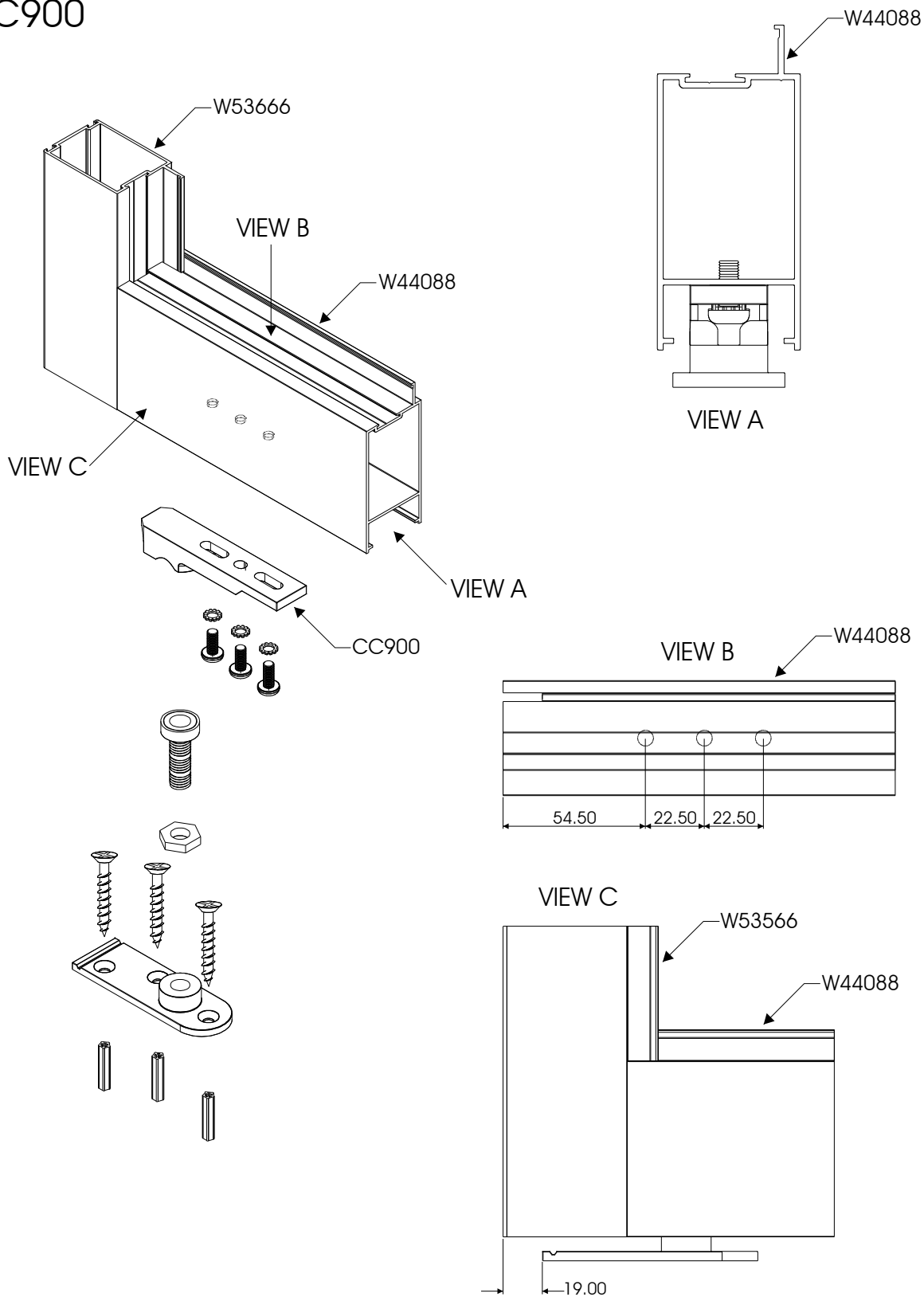

CLIP44 SHOPFRONT SYSTEM OVERHEAD DOOR CLOSER DOOR SETTING BLOCK LOCATION



GLAZING

1. SELECTION OF GLAZING METHODS

1.1 SETTING AND LOCATION BLOCKS

Glass-to-metal contact must be avoided at all times by using setting and location blocks having a hardness of 50° to 90° shore A durometer. Use only blocks made of Neoprene, EPDM, Silicone or other elastomeric material.

Setting blocks are to have a minimum thickness of 3mm and must be at least 27mm in length per square metre of glass area.

The position of the setting and location blocks is illustrated in Figure 2.

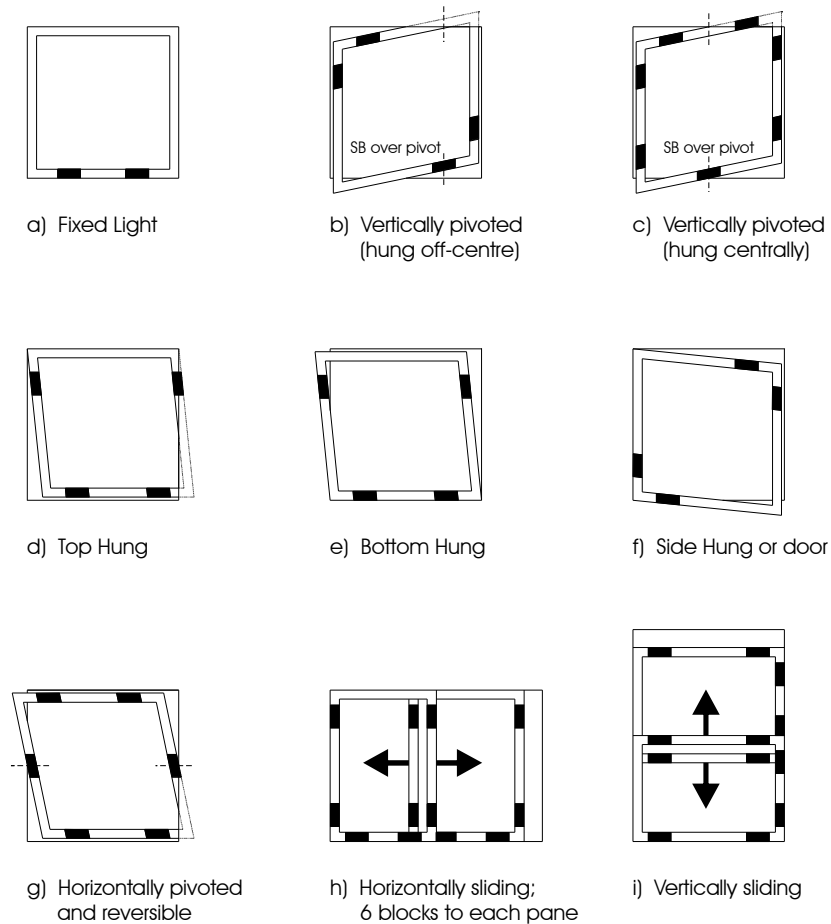

FIGURE 2 - POSITION OF SETTING AND LOCATION BLOCKS