

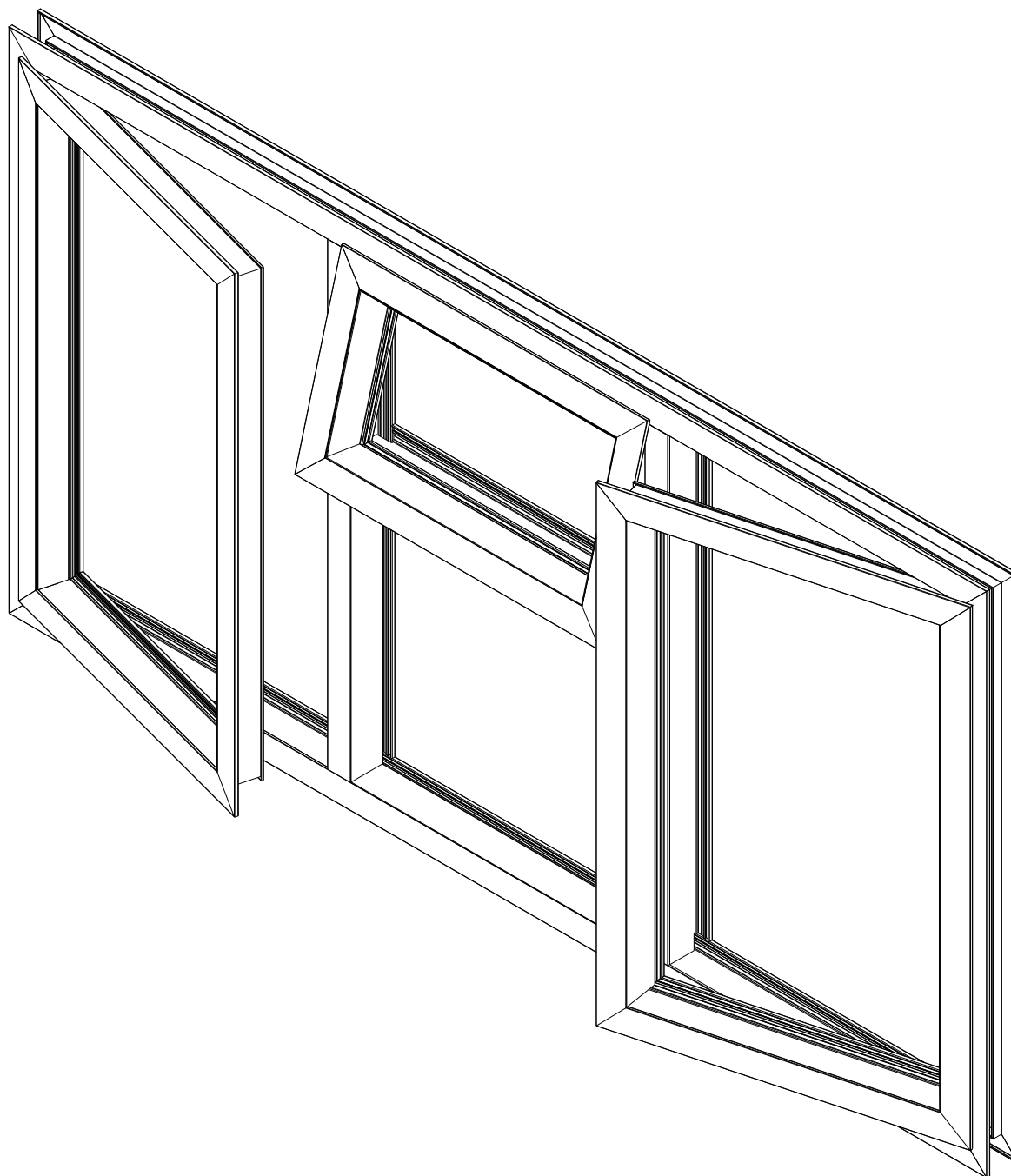

**crealco**

CASEMENT38

## CASEMENT 38 WINDOW



### PRODUCT MANUAL

Disclaimer: The right to make alterations is reserved

© 2013 Wispeco (Pty) Ltd, All Rights Reserved

Revision: August 2013



## Index

Legal Disclaimer	3
Profile Identification	4-5
Hardware Identification	6
Butterfly Gasket and Wedge Codes	7
Sash Limitation Charts	8
Standard Top Hung 600Pa Windload	9
Standard Top Hung 1000Pa Windload	10
Standard Top Hung 1500Pa Windload	11
Standard Side Hung 600Pa Windload	12
Standard Side Hung 1000Pa Windload	13
Standard Side Hung 1500Pa Windload	14
Top Hung Window Typical Configurations	15
Side Hung Window Typical Configurations	16
Fixing Details	17
Typical Coupling Configurations	18
Typical Cross Sectional Detail Double Top Hung Over Fixed	19
Typical Cross Sectional Detail Side Hung Over Fixed	20
Outer Frame Component Assembly Detail	21
Sash Frame Component Assembly Detail	22
Equal Leg Outer Frame Sill Level & Machining Detail	23
Mullion/Transome Machining Detail For End Milling On Equal Leg Outer Frame	24
Transom With Weather Bar Machining Detail For End Milling On Equal Leg Outer Frame	25
76mm Mullion Machining Detail For End Milling On Equal Leg Outer Frame	26
100mm Mullion Machining Detail For End Milling On Equal Leg Outer Frame	27
Corner Cleat Assembly Detail For Tubular Sash	28
Glazing Bar Frame Joint Assembly Detail	29
Cross Connector Assembly Detail	30
Glazing Procedure	31-32
Friction To Stay Assembly Detail	33
Fixing Lug Preparation Page	34
Handle Assembly Detail	35

**This manual must be read in conjunction with the Installation, Cleaning and Maintenance Document, BEE Certificates and the Performance Certificates for the relevant system. The manual must also be used in conjunction with the design and cutting list from the latest version of StarFront.**



## LEGAL DISCLAIMER

All information, recommendations or advice contained in this documentation is given in good faith to the best of Wispeco's knowledge and is based on current procedures in effect.

Since the actual use of this documentation by the user is beyond the control of Wispeco, such use is within the exclusive responsibility of the user. Wispeco cannot be held responsible for any loss incurred through incorrect or faulty use of this documentation.

Great care has been taken to ensure that the information provided is correct. Wispeco will accept no responsibility for any errors and/or omissions, which may have inadvertently occurred.

All mechanical joints must be sealed with a Wispeco approved joint sealer.

Laminated glass must not stand in water.

All drawings in the Wispeco Documentation are shown NOT to scale.

Wispeco cannot accept responsibility for the use of standard products since Wispeco does not know where these products are being installed.

The use of anti-magnetic stainless steel screws and pop rivets is recommended to reduce galvanic corrosion in harsh environments.

The hardware recommended in this documentation is suitable for use in most atmospheric environments. When hardware is used in severe coastal environments the manufacturer of the hardware must be consulted.

Fixing lugs on frames must be positioned as per the user manual and used in accordance to the AAAMSA specifications. When profiles are screwed together the screw centers must also be according to the user manual.

All glass used within Wispeco products must comply with SAGGA regulations.

All glazing above 10m from ground level must be signed off by a competent person (Glazing) in accordance with the national building regulations

**By continuing to use this documentation you acknowledge that you understand and accept the legal disclaimer.**

# CASEMENT 38 WINDOW PROFILE IDENTIFICATION

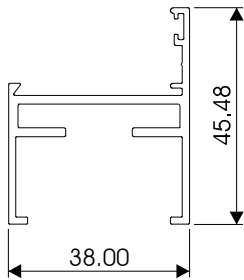

EQUAL LEG  
OUTER FRAME  
W24970

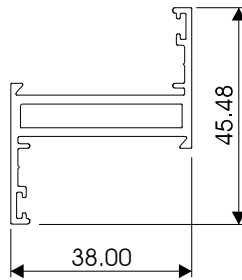

TUBULAR SASH  
W13267

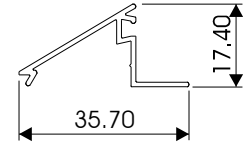

GLAZING  
BEAD 3mm - 5mm  
W24530

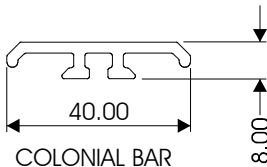

COLONIAL BAR  
W29247

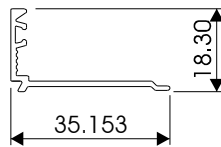

DOUBLE  
GLAZING BEAD 25mm  
W30312

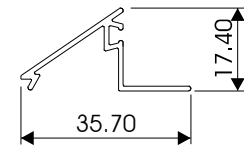

GLAZING  
BEAD 7 - 8mm  
W25200

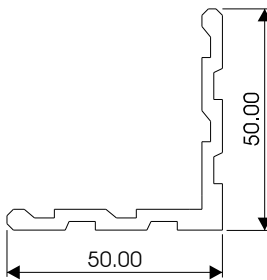

50mm  
CORNER CLEAT  
W52695

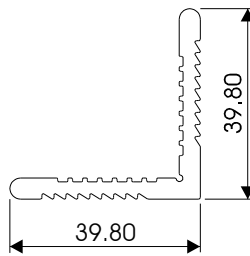

OSBORNE MULTI  
CORNER CLEAT  
W52538

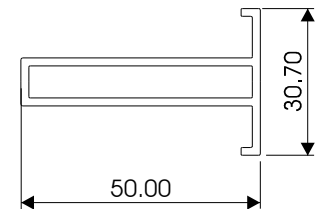

SMALL T COUPLING MULLION  
W11019

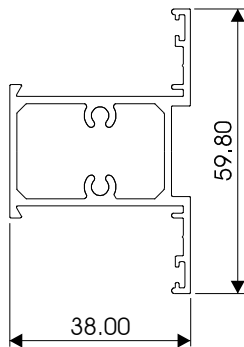

MULLION/  
TRANSOM  
W13268

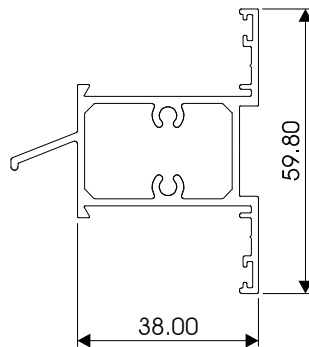

TRANSOM WITH  
WEATHER BAR  
W13408

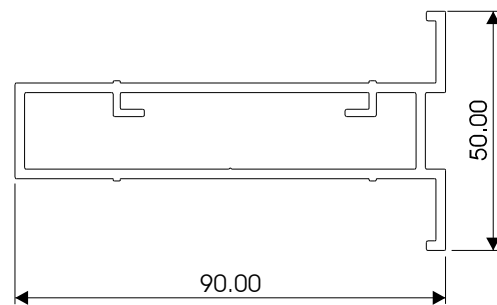

BIG T COUPLING MULLION  
W10593

# CASEMENT 38 WINDOW PROFILE IDENTIFICATION

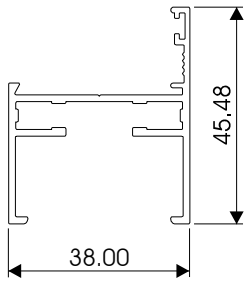

NEW CAS38 EQUAL LEG  
OUTER FRAME  
W32070

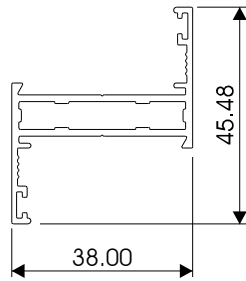

NEW CAS38 TUBULAR SASH  
W55717

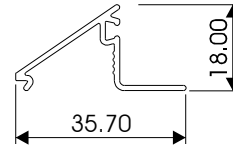

NEW CAS38 GLAZING  
BEAD 3mm - 5mm  
W31140

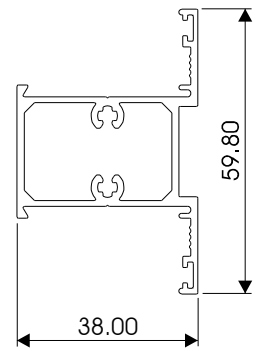

NEW CAS38 MULLION/  
TRANSOM  
W55718

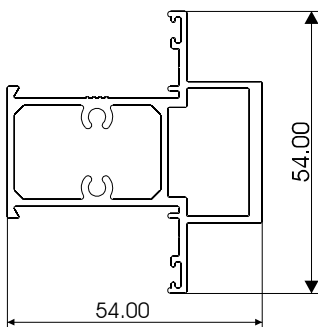

CAS38 MULLION  
W56796

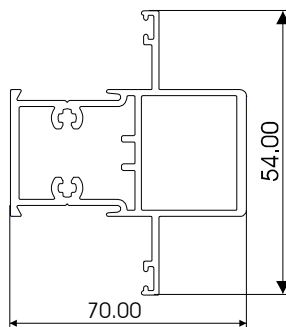

CAS38 MULLION  
W56797

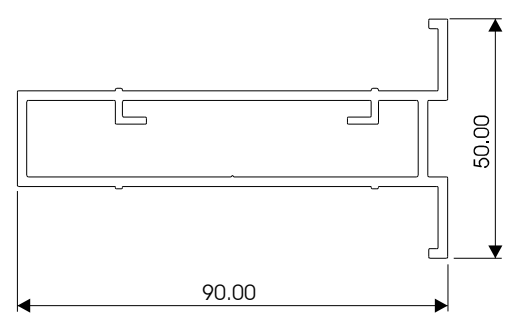

BIG T COUPLING MULLION  
W10593

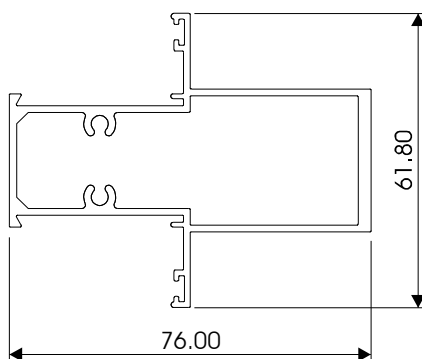

CAS38 76mm MULLION  
W54455

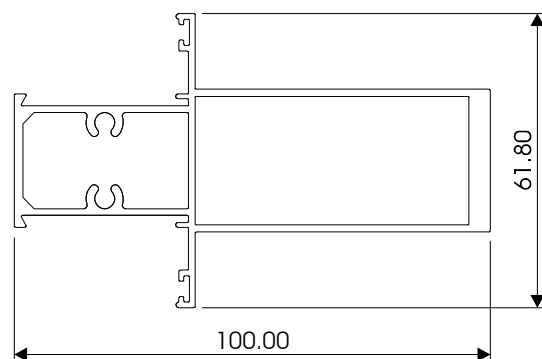

CAS38 100mm MULLION  
W54454

# CASEMENT 38 WINDOW HARDWARE IDENTIFICATION

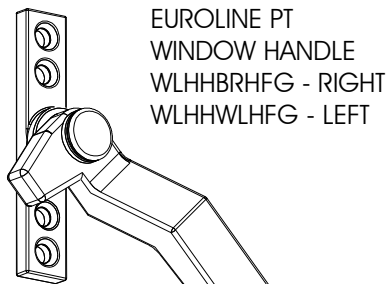

EUROLINE PT  
WINDOW HANDLE  
WLHHBRHFG - RIGHT  
WLHHWLHFG - LEFT



8x9 C/S  
HANDLE SCREW  
BLUNT POINT  
STPPS895

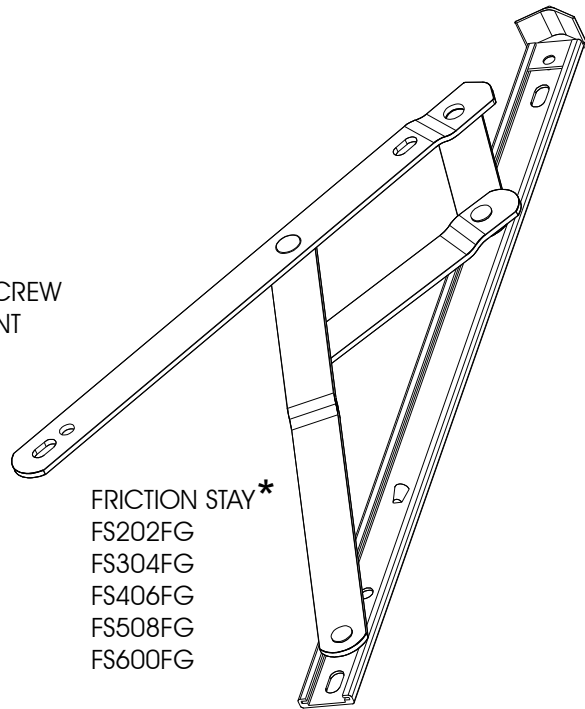

FRICION STAY\*  
FS202FG  
FS304FG  
FS406FG  
FS508FG  
FS600FG

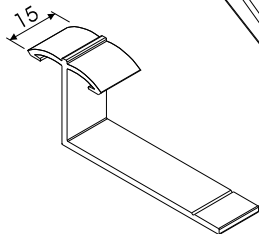

MULTI FIXING LUG ALUM 15mm  
FIX10627

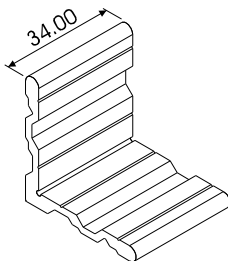

38 CASELITE  
CORNER CLEAT  
W24047

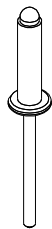

4.8x10  
DOME RIVET  
CSKR4810



8x30 P/HEAD POSI  
S/S SCREW  
STPPS830

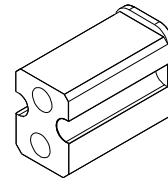

38 CROSS  
CONNECTOR GREY  
CC38

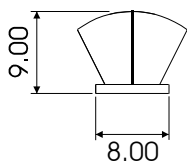

FINPILE  
FP48500FG

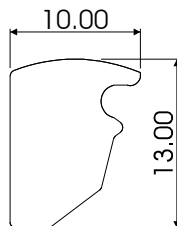

WEDGE H2  
CLRIV3FG

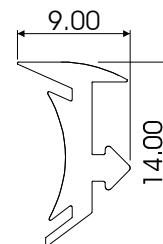

BUTTERFLY H20  
VP300FG

**\* MAINTENANCE OF STAINLESS STEEL FRICTION STAYS**

To preserve the appearance and prevent corrosion, wipe down Friction Stays with warm water and a mild detergent. For stubborn dirt or stains, use a non corrosive cleaner, for more aggressive stains add a small amount of vinegar to water. Carbon steel brushes and steel wool should be avoided as they may leave particles embedded in the surface which may lead to rusting. After cleaning rinse with hot water and dry using a clean cloth. Cleaning is recommended once a month or more frequently when subjected to regular use or heavy soiling.

CASEMENT 38  
 WINDOW  
 BUTTERFLY GASKET AND  
 WEDGE CODES



BUTTERFLY GASKET

● — B010

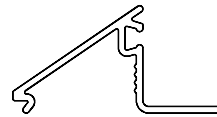

W31140 BEAD



● — W01G

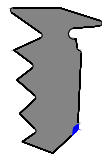

● — W02B



● — W03R

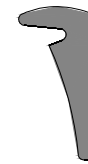

● — W04Y

WEDGES

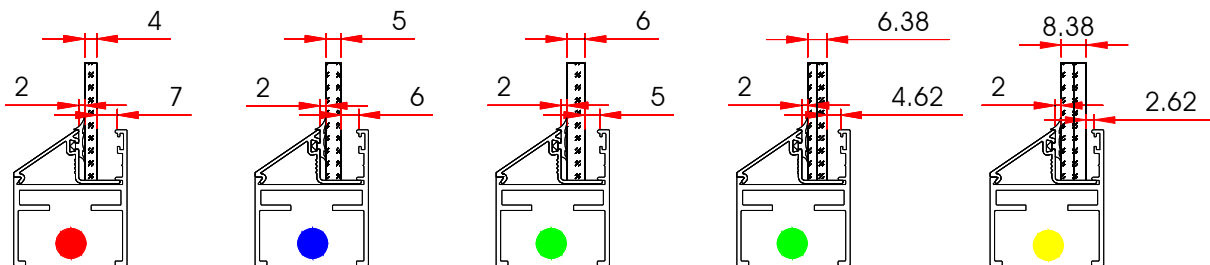

CASEMENT 38 WITH W31140 BEAD

# CASEMENT 38 WINDOW SASH LIMITATION CHARTS



		Maximum Vent Width in mm	Maximum Vent Height in mm
Top Hung	W13267	1500	1200

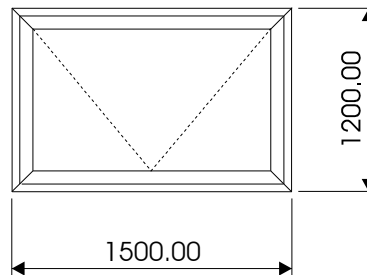

		Maximum Vent Width in mm	Maximum Vent Height in mm
Side Hung	W13267	700	1500

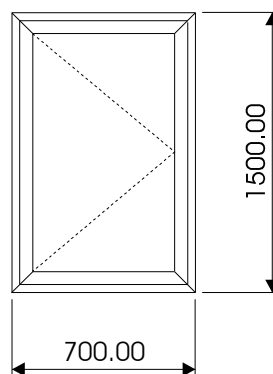

# CASEMENT 38 WINDOW STANDARD TOP HUNG 600Pa WINDLOAD



NOTE:

1. SEE THE MULLION LIMITATION CHART
2. OPENING SIZES SHOWN IN RED
3. ACTUAL WINDOW SIZES SHOWN IN BLACK AND BRACKETS.

	600 (590)	900 (890)	1 200 (1 190)	1 500 (1490)	1 800 (1790)	2 400 (2390)
600 (590)	 38 -0606T	 38 -0906T	 38 -1206T	 38 -1506T	 38 -1806TT	 38 -2406TT
900 (890)	 38 -0609T	 38 -0909T	 38 -1209T	 38 -1509T	 38 -1809TT	 38 -2409TT
1200 (1190)	 38 -0612T	 38 -0912T	 38 -1212DT	 38 -1512DT	 38 -1812DT	 38 -2412DT
1500 (1490)	 38 -0615DT	 38 -0915DT	 38 -1215DT	 38 -1515DT	 38 -1815DT	 38 -2415DT
1800 (1790)	 38 -0618DT	 38 -0918DT	 38 -1218DT	 38 -1518DT 76mm Mull W54455	 38 -1818DT 76mm Mull W54455	 38 -2418DT 76mm Mull W54455

# CASEMENT 38 WINDOW STANDARD TOP HUNG 1000Pa WINDLOAD



NOTE:

1. SEE THE MULLION LIMITATION CHART
2. OPENING SIZES SHOWN IN RED
3. ACTUAL WINDOW SIZES SHOWN IN BLACK AND BRACKETS.

	600 (590)	900 (890)	1 200 (1 190)	1 500 (1490)	1 800 (1790)	2 400 (2390)
600 (590)	 38 -0606T	 38 -0906T	 38 -1206T	 38 -1506T	 38 -1806TT	 38 -2406TT
900 (890)	 38 -0609T	 38 -0909T	 38 -1209T	 38 -1509T	 38 -1809TT	 38 -2409TT
1200 (1190)	 38 -0612T	 38 -0912T	 38 -1212DT	 38 -1512DT	 38 -1812DT	 38 -2412DT
1500 (1490)	 38 -0615DT	 38 -0915DT	 38 -1215DT	 38 -1515DT 76mm Mull W54455	 38 -1815DT 76mm Mull W54455	 38 -2415DT 76mm Mull W54455
1800 (1790)	 38 -0618DT	 38 -0918DT	 38 -1218DT 76mm Mull W54455	 38 -1518DT 76mm Mull W54455	 38 -1818DT 76mm Mull W54455	 38 -2418DT 76mm Mull W54455

# CASEMENT 38 WINDOW STANDARD TOP HUNG 1 500Pa WINDLOAD



NOTE:

1. SEE THE MULLION LIMITATION CHART
2. OPENING SIZES SHOWN IN RED
3. ACTUAL WINDOW SIZES SHOWN IN BLACK AND BRACKETS.







	600 (590)	900 (890)	1 200 (1 190)	1 500 (1490)	1 800 (1790)	2 400 (2390)
600 (590)	 38 -0606T	 38 -0906T	 38 -1206T	 38 -1506T	 38 -1806TT	 38 -2406TT
900 (890)	 38 -0609T	 38 -0909T	 38 -1209T	 38 -1509T	 38 -1809TT	 38 -2409TT
1200 (1190)	 38 -0612T	 38 -0912T	 38 -1212DT	 38 -1512DT	 38 -1812DT	 38 -2412DT
1500 (1490)	 38 -0615DT	 38 -0915DT	 38 -1215DT 76mm Mull W54455	 38 -1515DT 76mm Mull W54455	 38 -1815DT 76mm Mull W54455	 38 -2415DT 76mm Mull W54455
1800 (1790)	 38 -0618DT	 38 -0918DT	 38 -1218DT 76mm Mull W54454	 38 -1518DT 76mm Mull W54454	 38 -1818DT 76mm Mull W54454	 38 -2418DT 76mm Mull W54454

# CASEMENT 38 WINDOW STANDARD SIDE HUNG 600Pa WINDLOAD

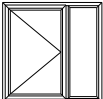
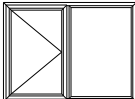
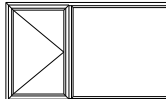
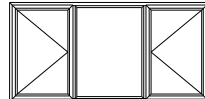

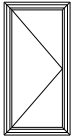
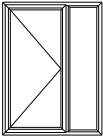
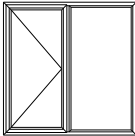
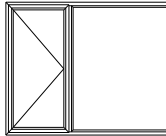
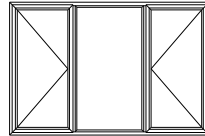
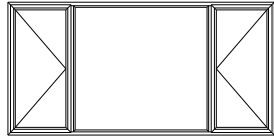
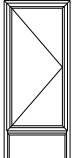
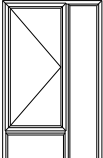
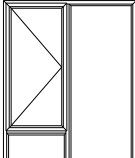
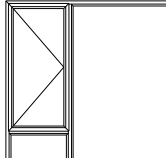
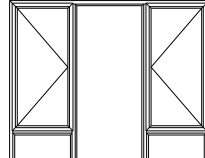
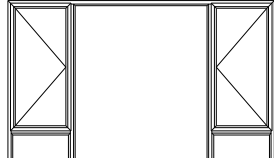
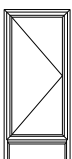
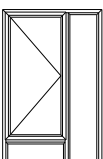
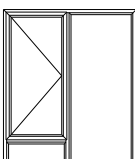
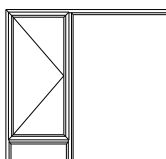
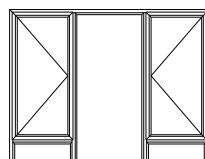
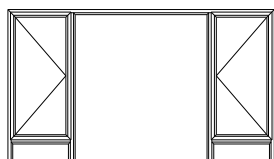
NOTE:

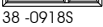
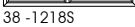
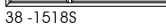
1. SEE THE MULLION LIMITATION CHART
2. OPENING SIZES SHOWN IN RED
3. ACTUAL WINDOW SIZES SHOWN IN BLACK AND BRACKETS.



	600 (590)	900 (890)	1 200 (1 190)	1 500 (1490)	1 800 (1790)	2 400 (2390)
600 (590)	 38 -0609S	 38 -0909S	 38 -1209S	 38 -1509S	 38 -1809SS	 38 -2409SS
900 (890)	 38 -0612S	 38 -0912S	 38 -1212S	 38 -1512S	 38 -1812SS	 38 -2412SS
1200 (1190)	 38 -0615S	 38 -0915S	 38 -1215S	 38 -1515S	 38 -1815SS	 38 -2415SS
1500 (1490)	 38 -0618S	 38 -0918S	 38 -1218S	 38 -1518S	 38 -1818SS	 38 -2418SS
1800 (1790)	 38 -0618S	 38 -0918S	 38 -1218S	 38 -1518S	 38 -1818SS	 38 -2418SS

# CASEMENT 38 WINDOW STANDARD SIDE HUNG 1000Pa WINDLOAD

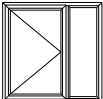
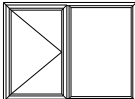
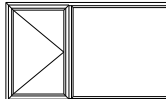
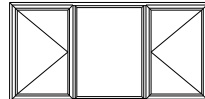

NOTE:

1. SEE THE MULLION LIMITATION CHART
2. OPENING SIZES SHOWN IN RED
3. ACTUAL WINDOW SIZES SHOWN IN BLACK AND BRACKETS.

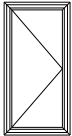
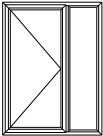
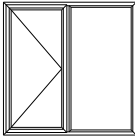
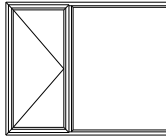
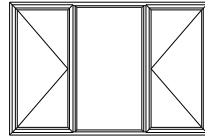
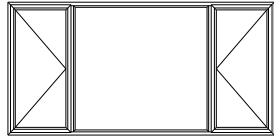
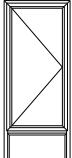
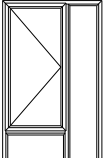
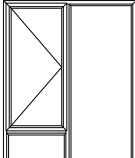
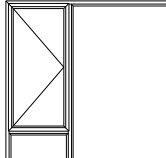
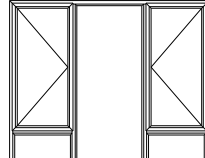
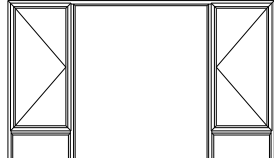
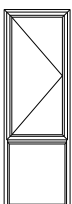
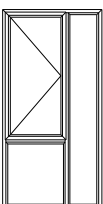
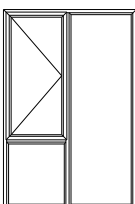
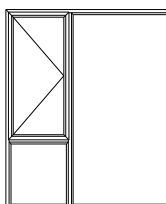
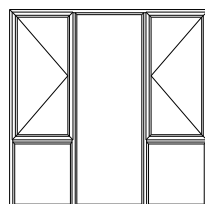
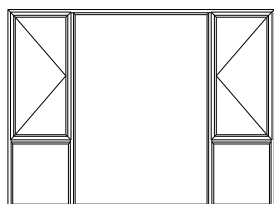
	600 (590)	900 (890)	1 200 (1 190)	1 500 (1490)	1 800 (1790)	2 400 (2390)
600 (590)	 38 -0609S	 38 -0909S	 38 -1209S	 38 -1509S	 38 -1809SS	 38 -2409SS
900 (890)	 38 -0612S	 38 -0912S	 38 -1212S	 38 -1512S	 38 -1812SS	 38 -2412SS
1200 (1190)	 38 -0615S	 38 -0915S	 38 -1215S	 38 -1515S	 38 -1815SS	 38 -2415SS
1500 (1490)	 38 -0618S	 38 -0918S	 38 -1218S	 38 -1518S	 38 -1818SS	 38 -2418SS
1800 (1790)	 38 -0618S	 38 -0918S	 38 -1218S	 38 -1518S	 38 -1818SS	 38 -2418SS

# CASEMENT 38 WINDOW STANDARD SIDE HUNG 1 500Pa WINDLOAD



NOTE:

1. SEE THE MULLION LIMITATION CHART
2. OPENING SIZES SHOWN IN RED
3. ACTUAL WINDOW SIZES SHOWN IN BLACK AND BRACKETS.

	600 (590)	900 (890)	1 200 (1 190)	1 500 (1 490)	1 800 (1 790)	2 400 (2 390)
600 (590)	 38 -0609S	 38 -0909S	 38 -1209S	 38 -1509S	 38 -1809SS	 38 -2409SS
900 (890)	 38 -0612S	 38 -0912S	 38 -1212S	 38 -1512S	 38 -1812SS	 38 -2412SS
1 200 (1 190)	 38 -0615S	 38 -0915S	 38 -1215S	 38 -1515S	 38 -1815SS	 38 -2415SS
1 500 (1 490)	 38 -0618S	 38 -0918S	 38 -1218S	 38 -1518S	 38 -1818SS	 38 -2418SS
1 800 (1 790)						

CASEMENT 38  
WINDOW  
STANDARD TOP HUNG WINDOW  
TYPICAL CONFIGURATIONS

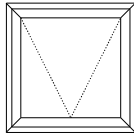

**A**  
SINGLE TOP HUNG

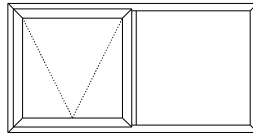

**BB**  
TOP HUNG  
NEXT TO FIXED

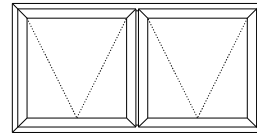

**CC**  
TOP HUNG NEXT  
TO TOP HUNG

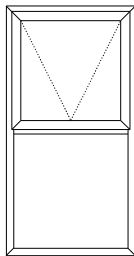

**B**  
TOP HUNG  
OVER FIXED

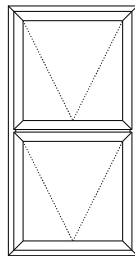

**C**  
TOP HUNG  
OVER TOP HUNG

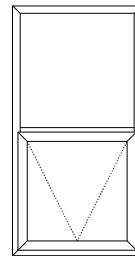

**E**  
FIXED OVER  
TOP HUNG

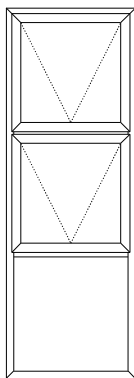

**D**  
DOUBLE TOP HUNG  
OVER FIXED

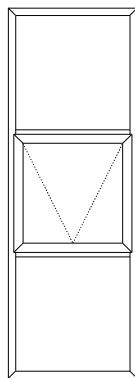

**DD**  
FIXED OVER  
TOP HUNG  
OVER FIXED

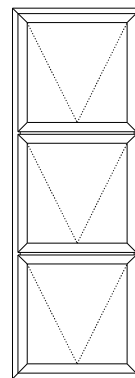

**EE**  
TRIPLE TOP HUNG

CASEMENT 38  
WINDOW  
STANDARD SIDE HUNG WINDOW  
TYPICAL CONFIGURATIONS

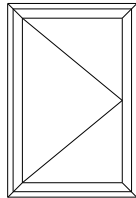

**A**  
SINGLE SIDE HUNG

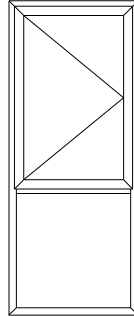

**B**  
SIDE HUNG  
OVER FIXED

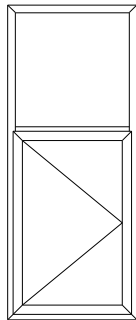

**C**  
FIXED OVER  
SIDE HUNG

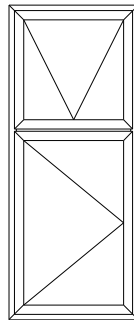

**D**  
TOP HUNG  
OVER SIDE HUNG

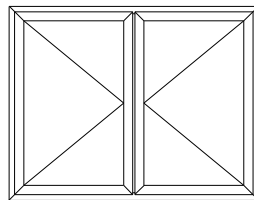

**CC**  
SIDE HUNG NEXT  
TO SIDE HUNG

# CASEMENT 38 WINDOW FIXING DETAILS

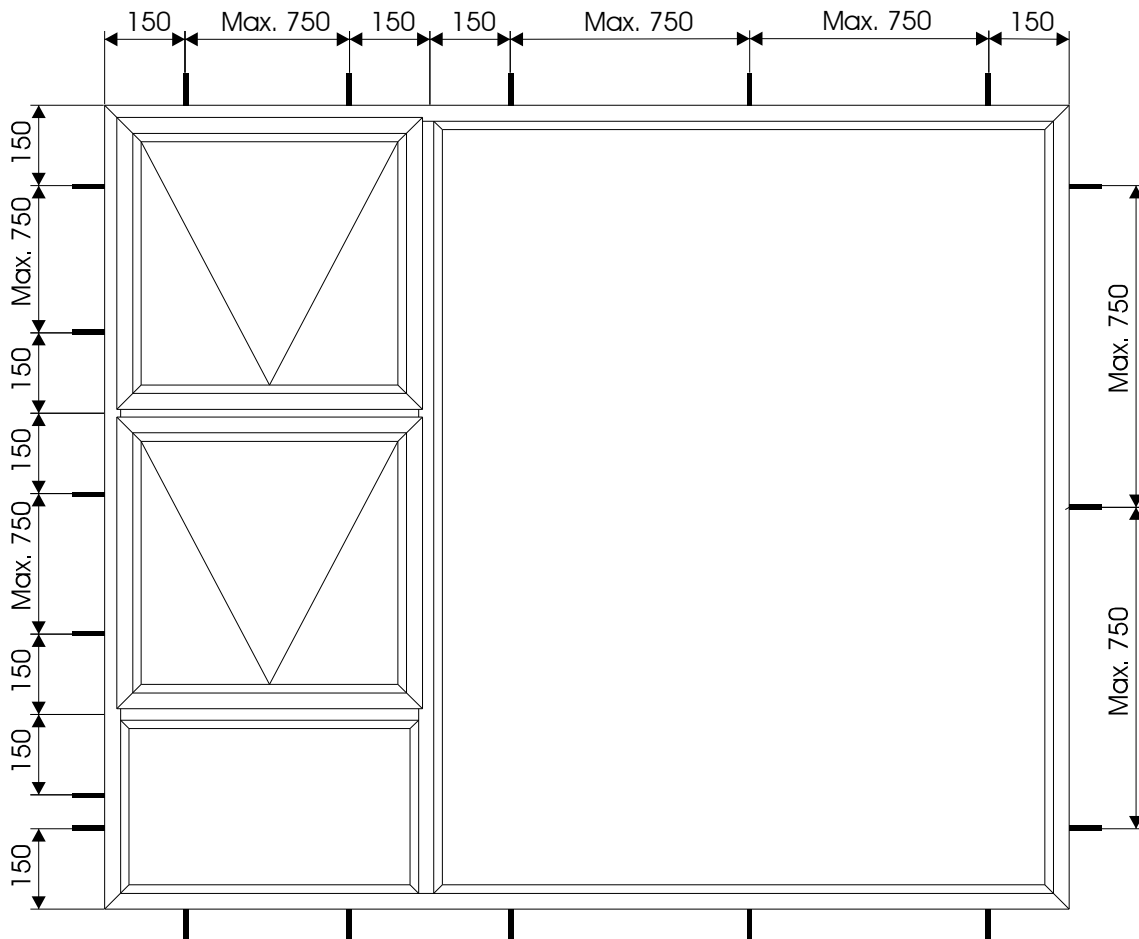
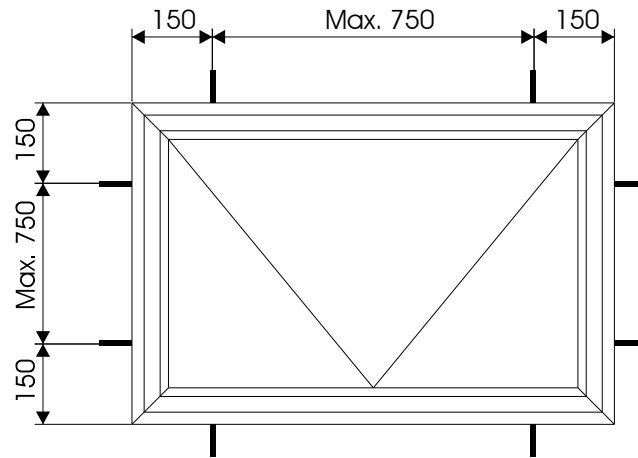

## General:

The window is fixed into position - the sill is then built at a later stage - the bottom lugs can be left in place but it is often found that most times the mason either bends them out of his way or breaks them off. This practically means that most windows are only secured on 3 sides.

CASEMENT 38  
WINDOW  
TYPICAL COUPLING  
CONFIGURATIONS

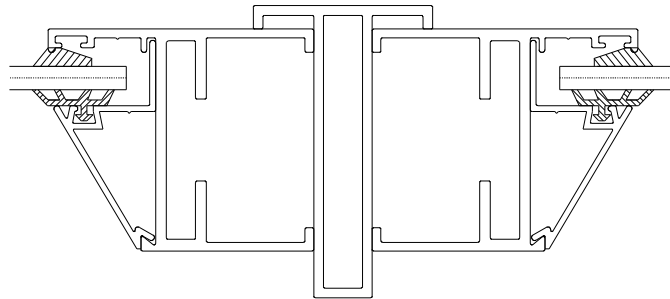

MULLION COUPLING DETAIL  
EQUAL LEG OUTER FRAME &  
SMALL T COUPLING MULLION  
(W24970 + W11019)

MAXIMUM HEIGHT: 1500mm

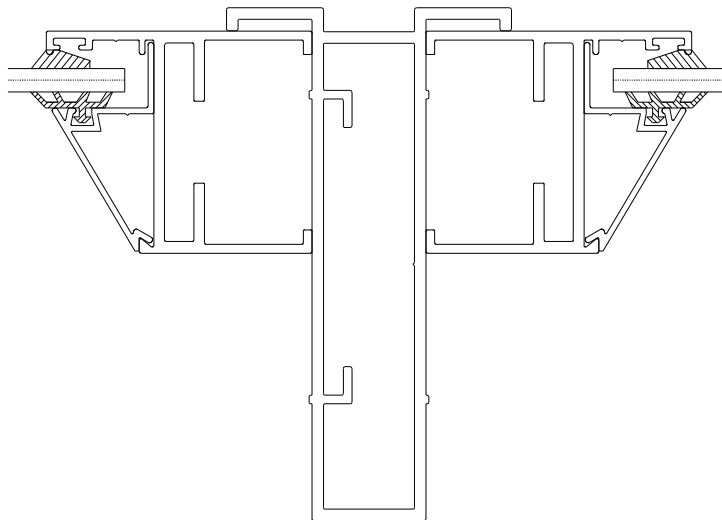

MULLION COUPLING DETAIL  
EQUAL LEG OUTER FRAME &  
BIG T COUPLING MULLION  
(W24970 + W10593)

MAXIMUM HEIGHT: 1500mm

# CASEMENT 38 WINDOW TYPICAL CROSS SECTIONAL DETAIL DOUBLE TOP HUNG OVER FIXED

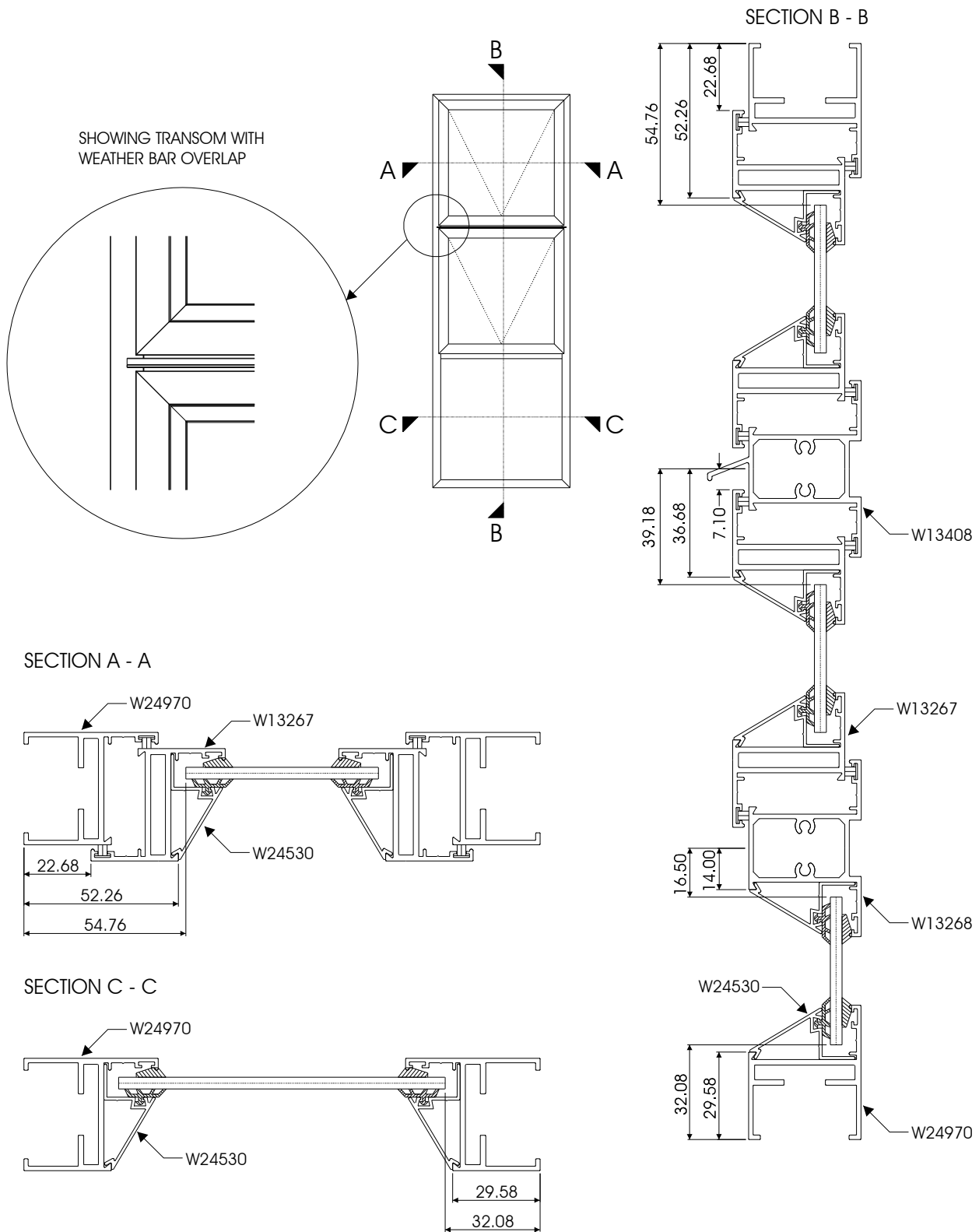

CASEMENT 38  
 WINDOW  
 TYPICAL CROSS SECTIONAL DETAIL  
 SIDE HUNG OVER FIXED

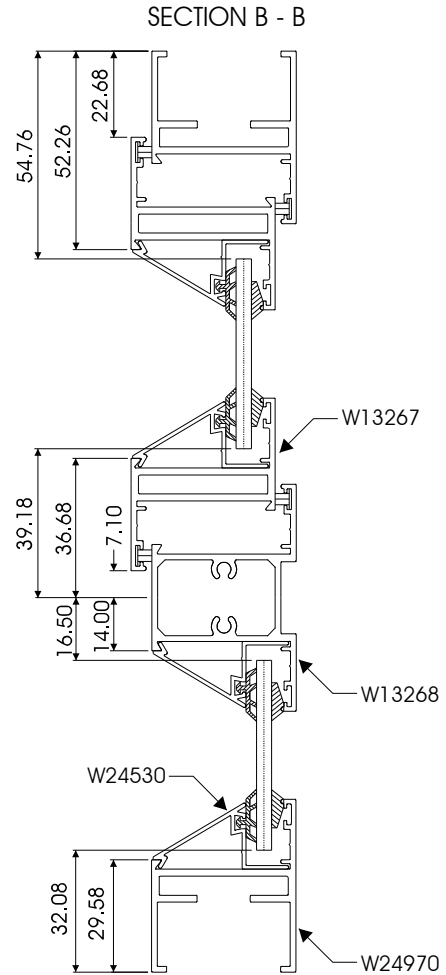
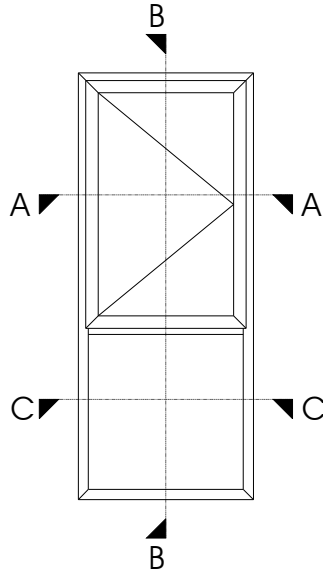

SECTION A - A

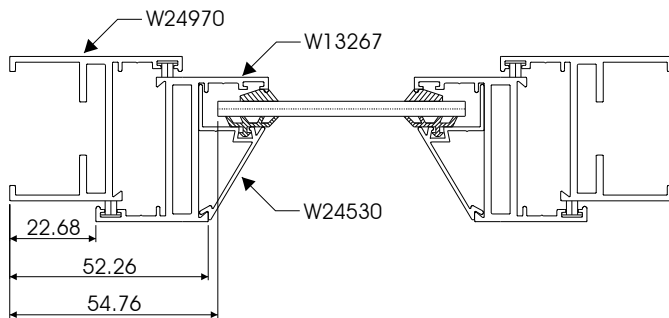

SECTION C - C

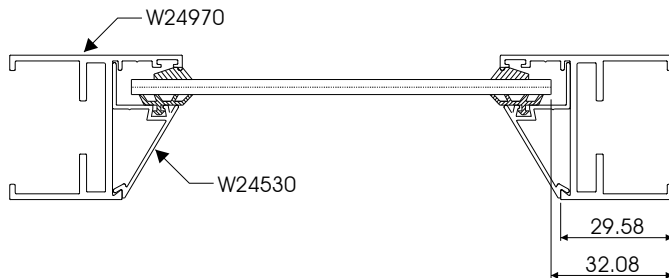

# CASEMENT 38 WINDOW OUTER FRAME COMPONENT ASSEMBLY DETAIL

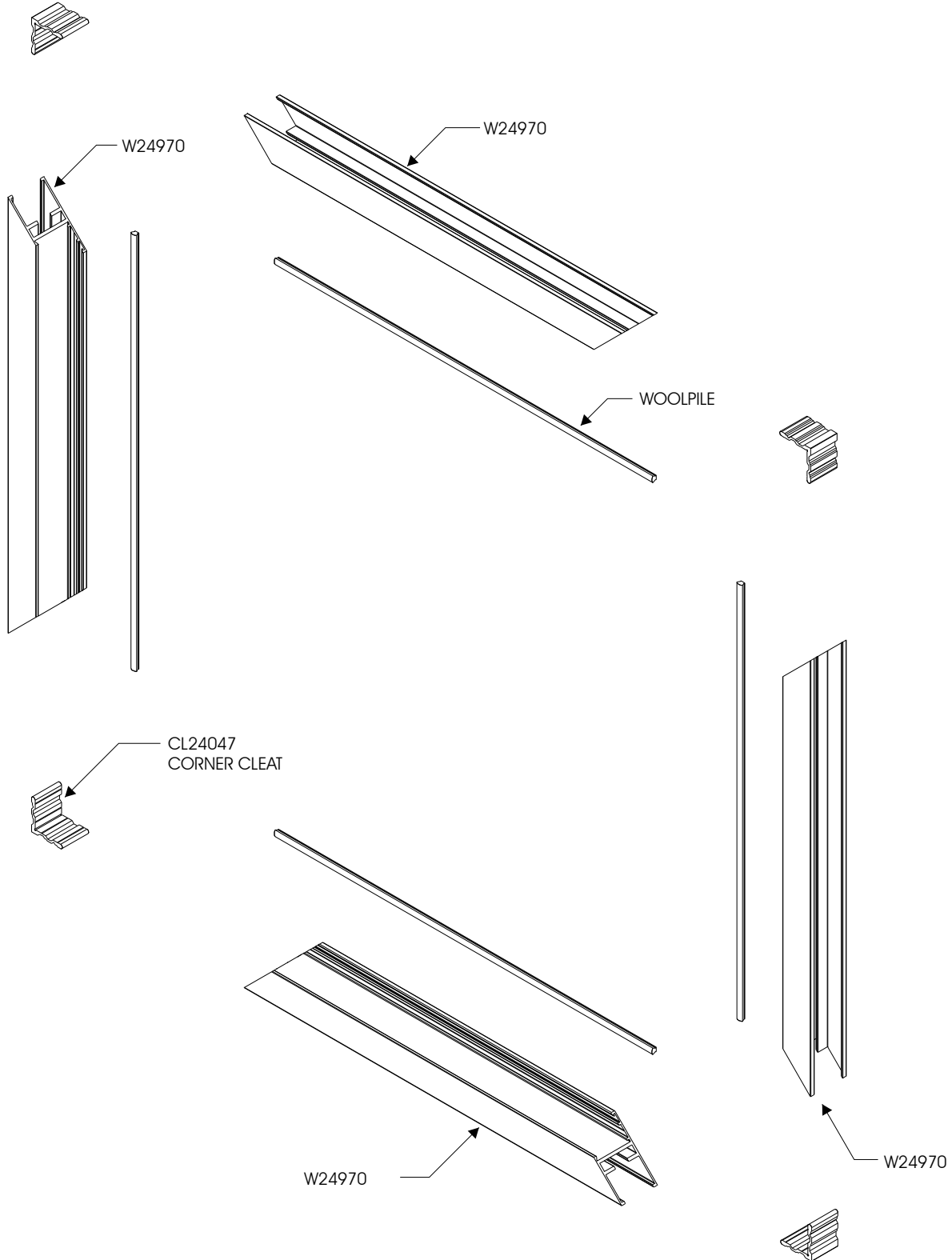

# CASEMENT 38 WINDOW SASH FRAME COMPONENT ASSEMBLY DETAIL

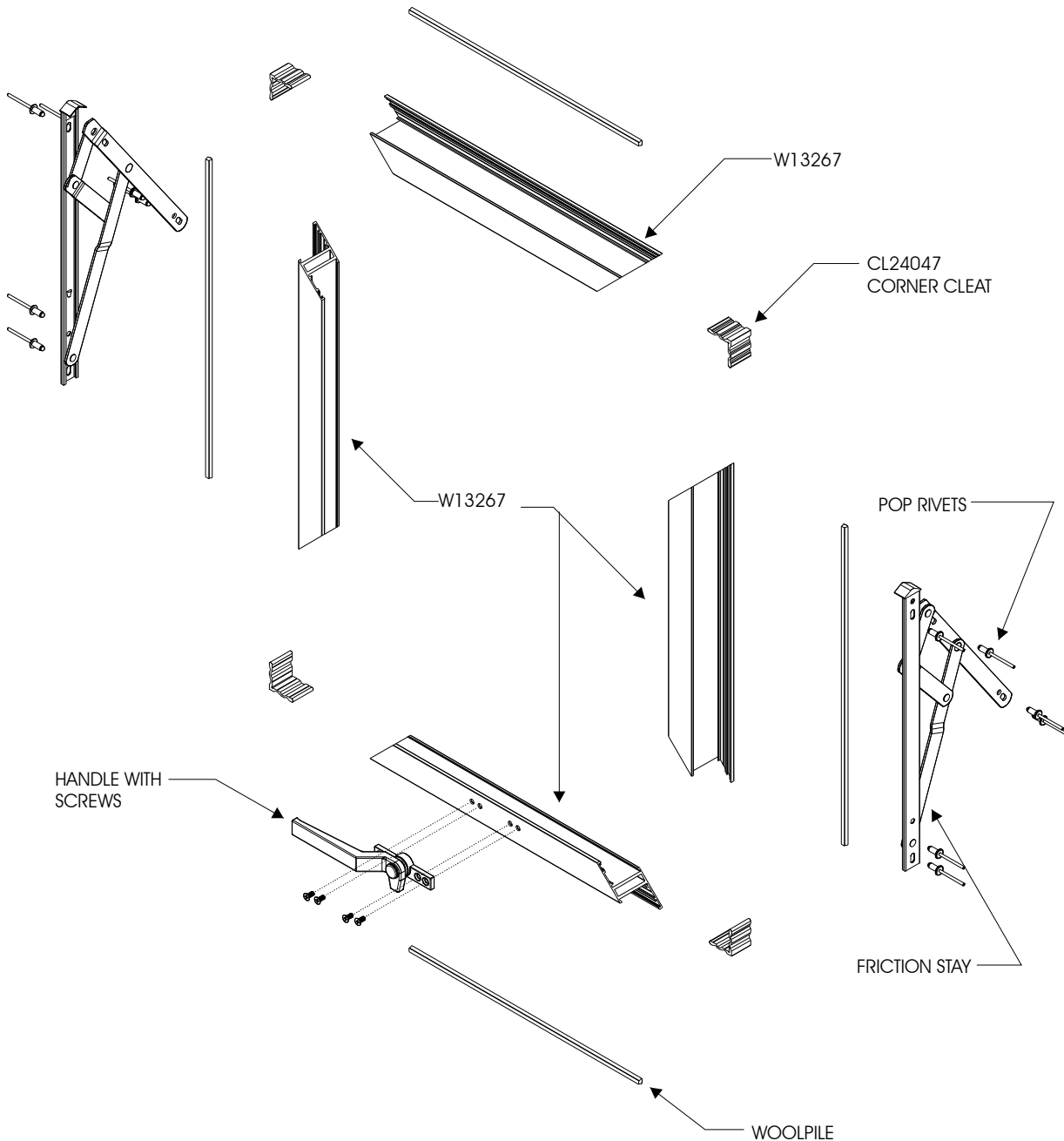

CASEMENT 38  
WINDOW  
EQUAL LEG OUTER FRAME  
SILL LEVEL & MACHINING DETAIL

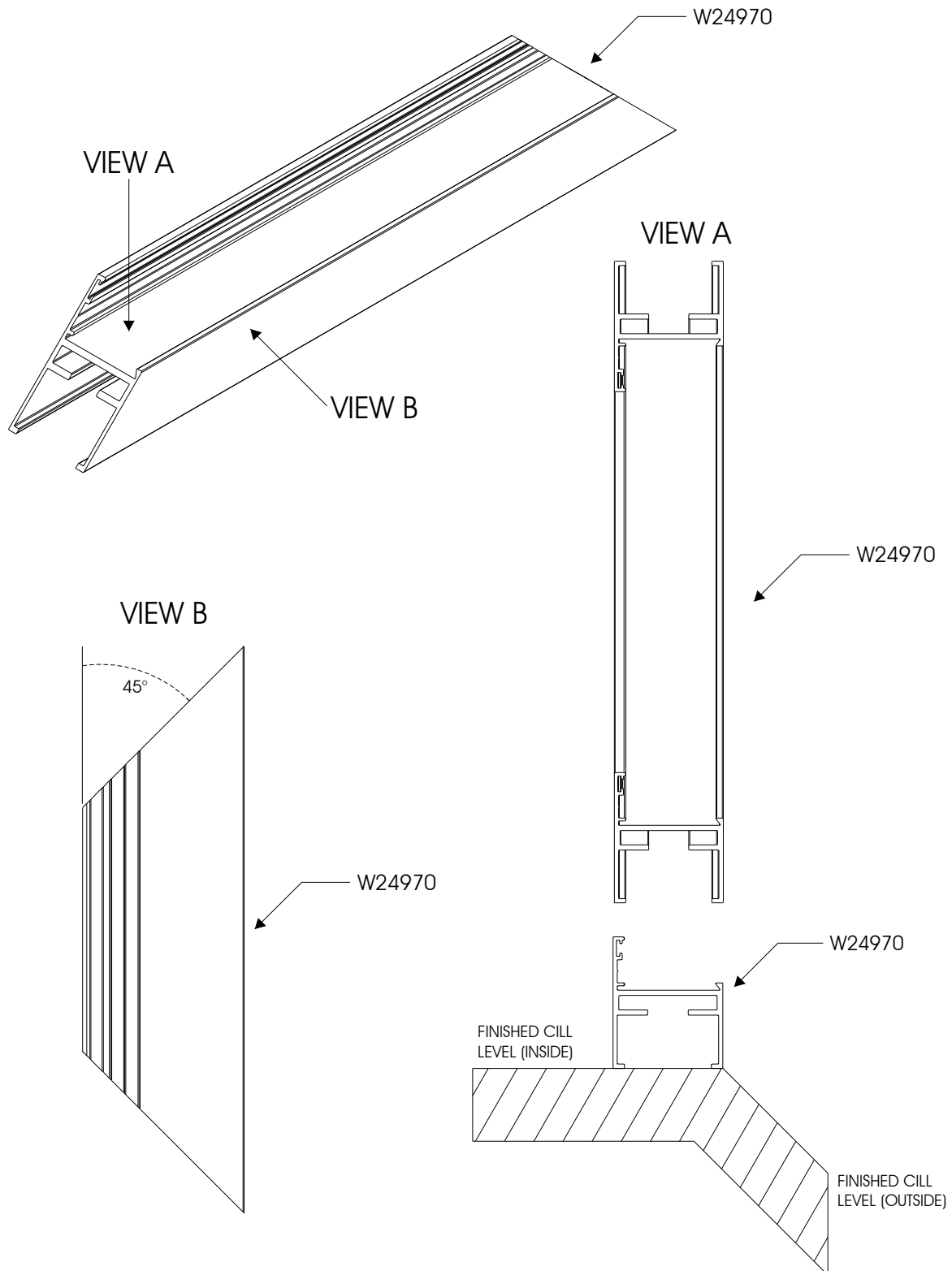

CASEMENT 38  
 WINDOW  
 MULLION / TRANSOME MACHINING  
 DETAIL FOR END MILLING  
 ON EQUAL LEG OUTER FRAME

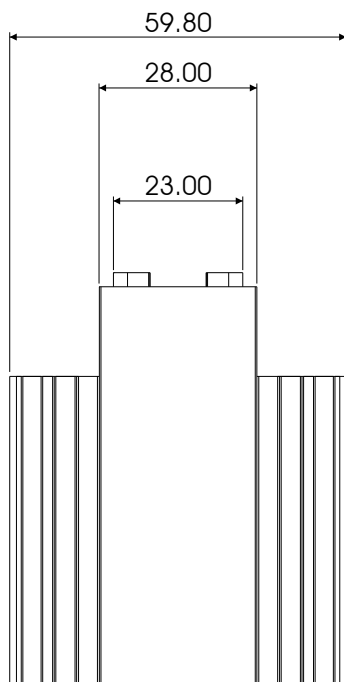
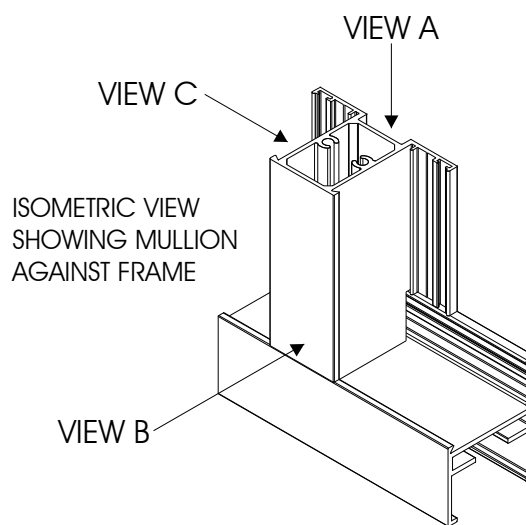
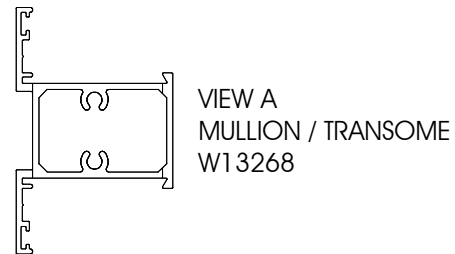
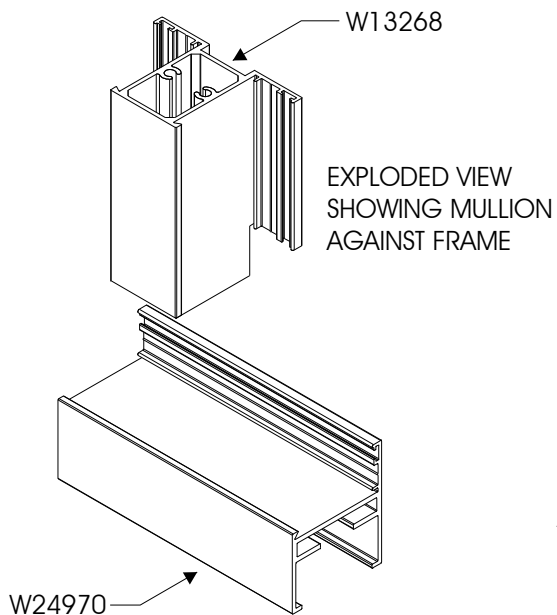

VIEW B

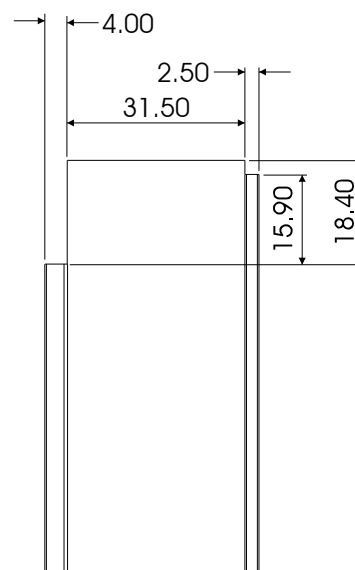

VIEW C

CASEMENT 38  
 WINDOW  
 TRANSOM WITH WEATHER BAR  
 MACHINING DETAIL FOR END MILLING  
 ON EQUAL LEG OUTER FRAME

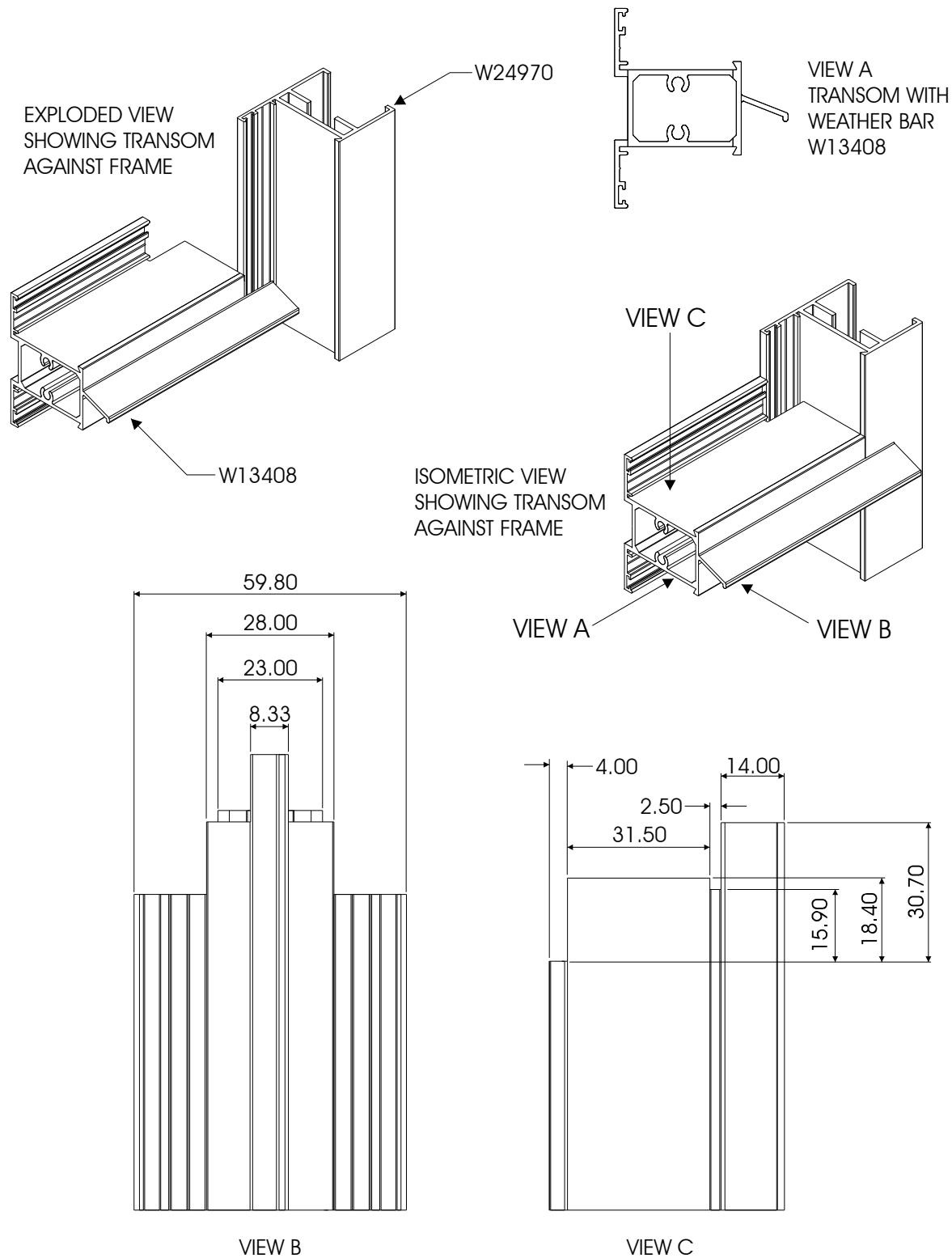

CASEMENT 38  
 WINDOW  
 76mm MULLION MACHINING DETAIL  
 FOR END MILLING  
 ON EQUAL LEG OUTER FRAME

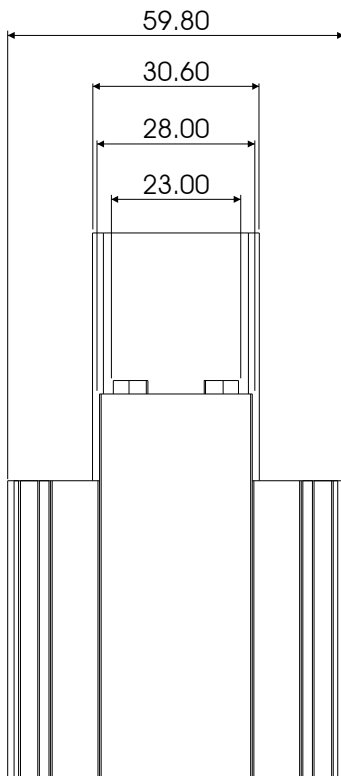
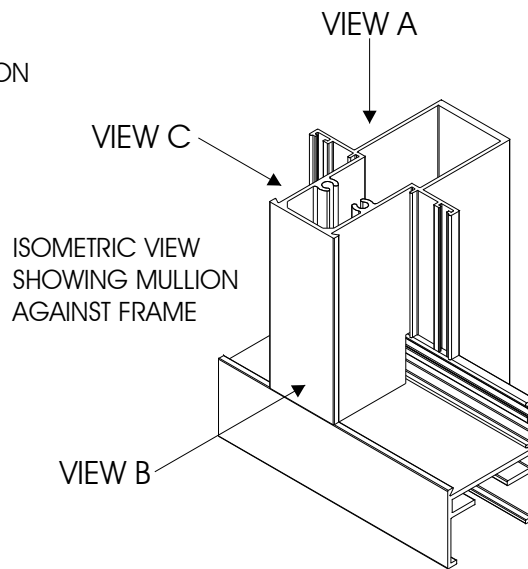
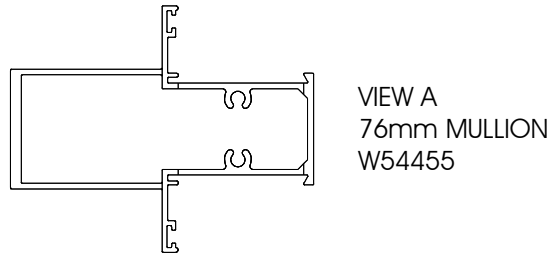
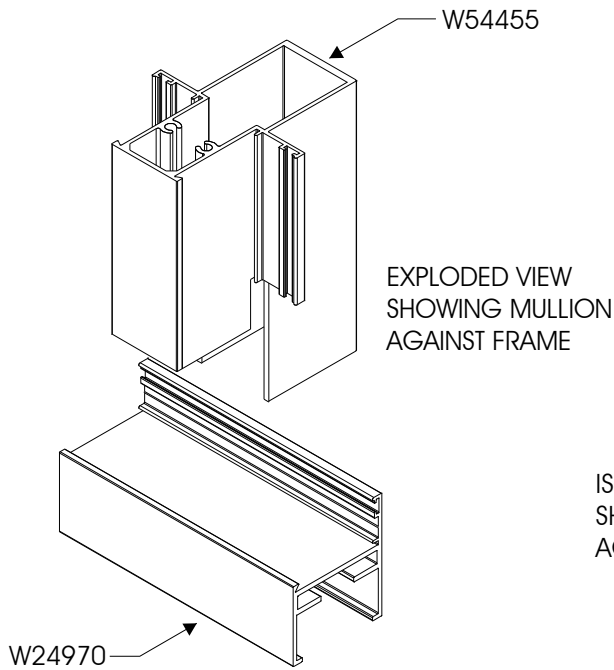

VIEW B

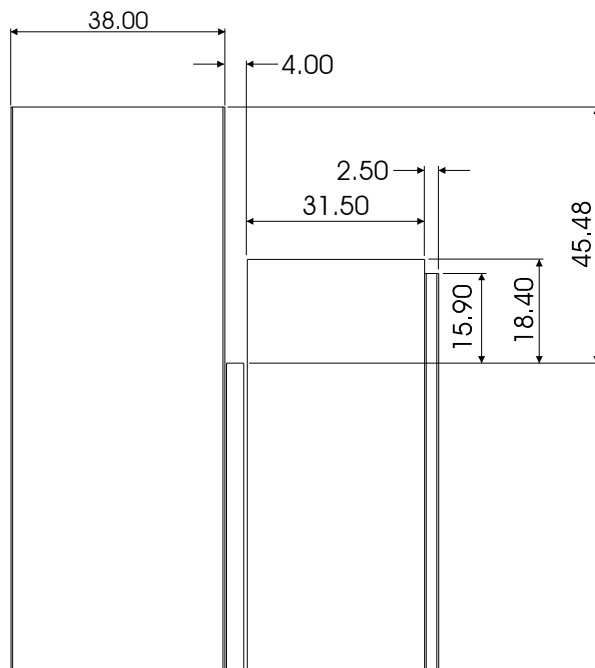

VIEW C

CASEMENT 38  
 WINDOW  
 100mm MULLION MACHINING  
 DETAIL FOR END MILLING  
 ON EQUAL LEG OUTER FRAME

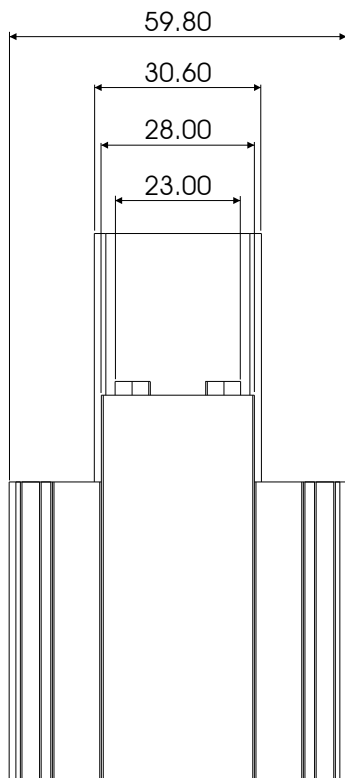
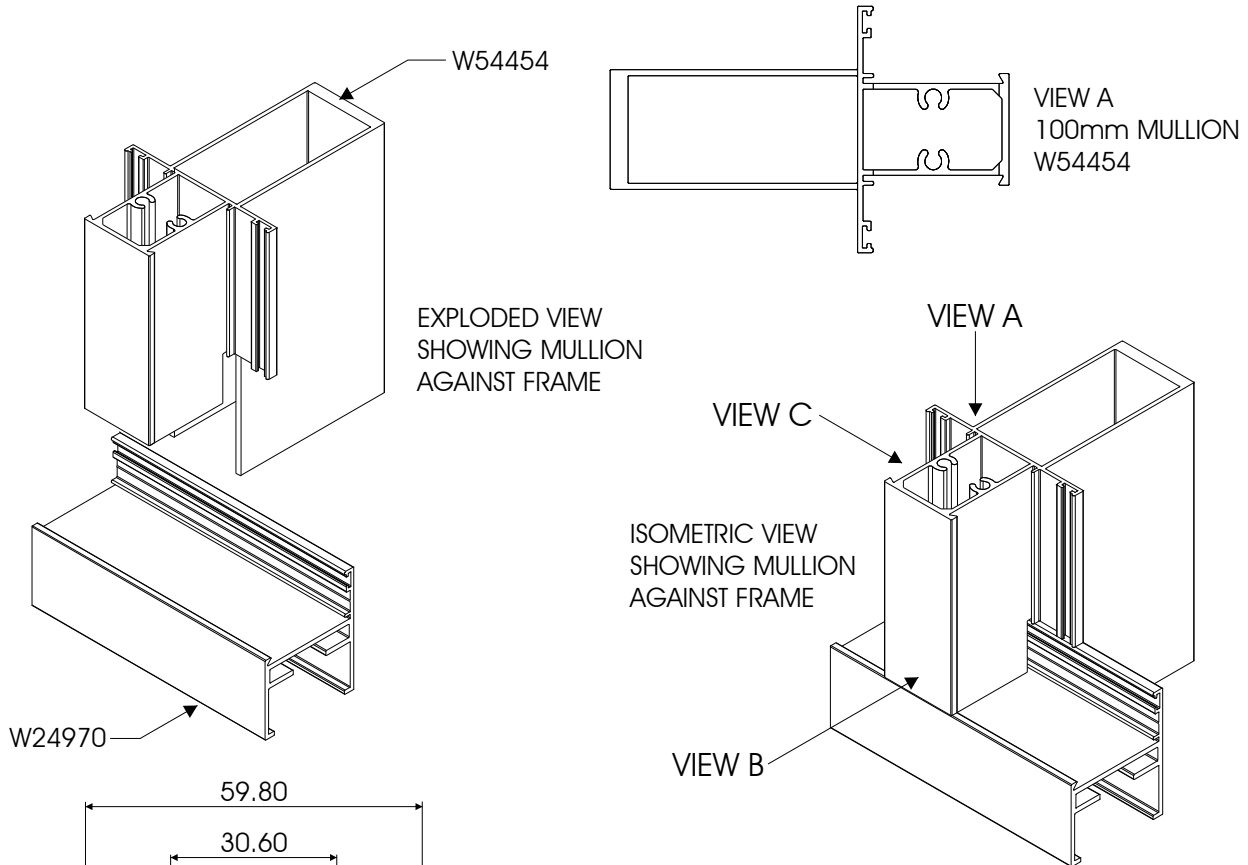

VIEW B

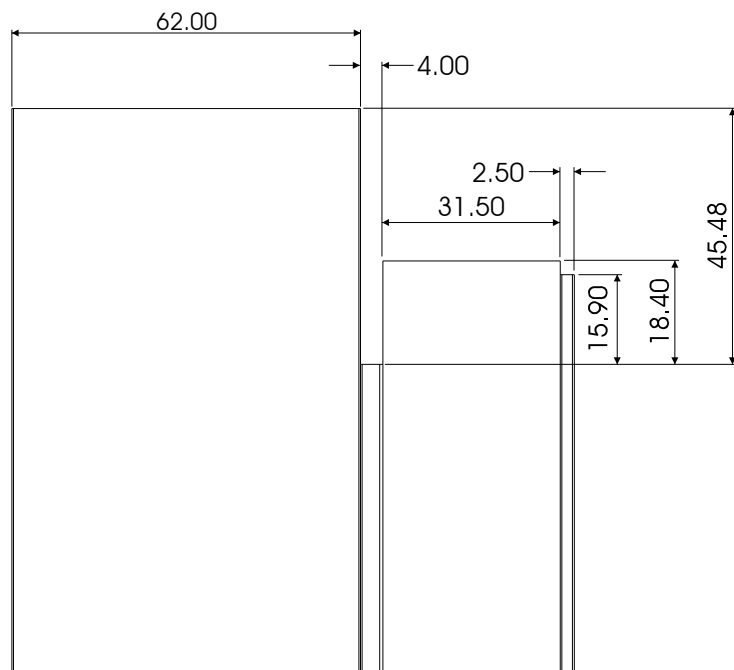

VIEW C

CASEMENT 38  
 WINDOW  
 CORNER CLEAT ASSEMBLY DETAIL  
 FOR TUBULAR SASH

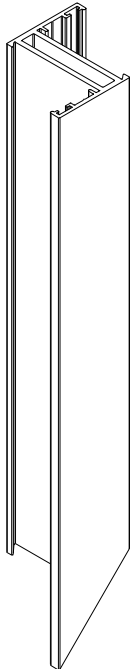

NOTE:  
 ALL JOINTS MUST BE SEALED WITH  
 SMALL JOINT SEALANT. FINPILE  
 MUST BE FITTED TO SASH AND  
 CORRESPONDING SURFACES OF  
 FRAME BEFORE CRIMPING (NOT  
 TO AREAS TO BE GLAZED)

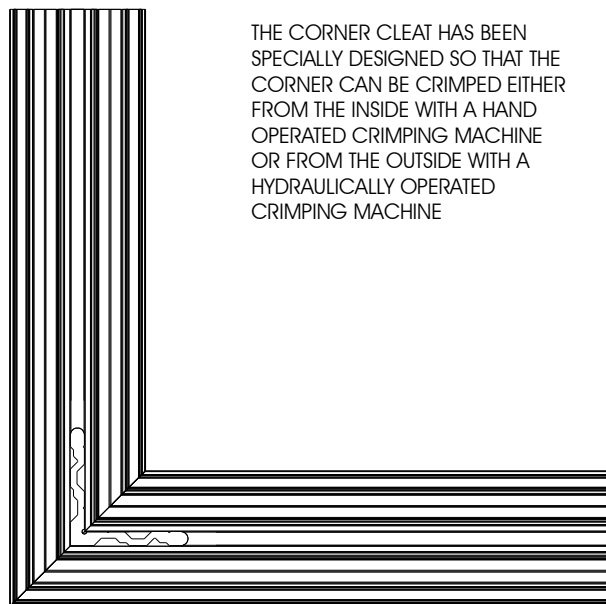
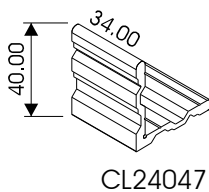
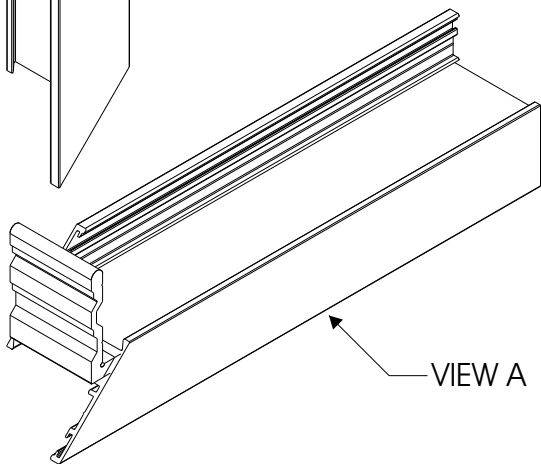
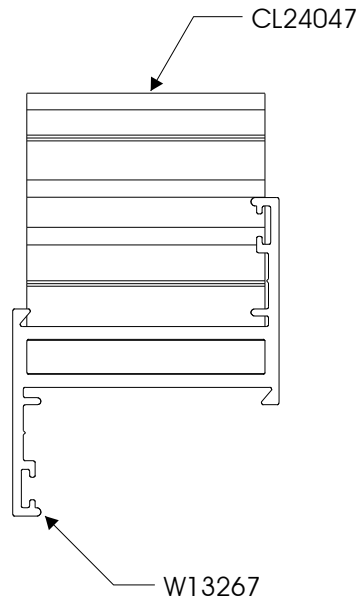

THE CORNER CLEAT HAS BEEN  
 SPECIALLY DESIGNED SO THAT THE  
 CORNER CAN BE CRIMPED EITHER  
 FROM THE INSIDE WITH A HAND  
 OPERATED CRIMPING MACHINE  
 OR FROM THE OUTSIDE WITH A  
 HYDRAULICALLY OPERATED  
 CRIMPING MACHINE

VIEW A

# CASEMENT 38 WINDOW GLAZING BAR FRAME JOINT ASSEMBLY DETAIL



NOTE: ALL JOINTS MUST BE SEALED WITH SMALL JOINT SEALANT. FINPILE MUST BE FITTED PRIOR TO ASSEMBLY IF SASH IS TO BE FITTED INTO FRAME. FINPLIE MUST NOT RUN BEHIND GLAZING BAR AND GAP MUST BE SEALED TO PREVENT WATER INFILTRATION.

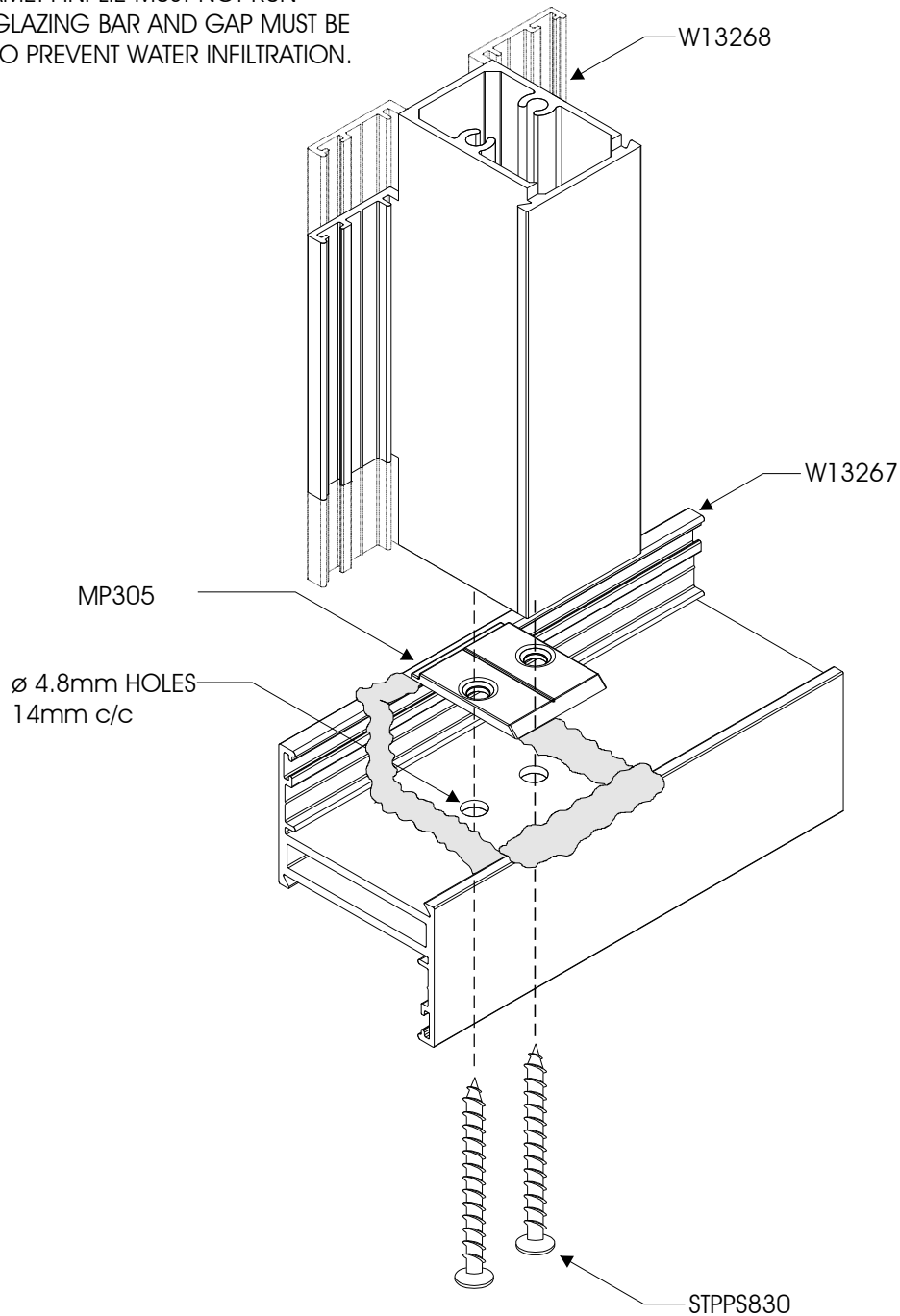

# CASEMENT 38 WINDOW CROSS CONNECTOR ASSEMBLY DETAIL



NOTE: ALL JOINTS MUST BE SEALED WITH SMALL JOINT SEALANT. FINPILE MUST BE FITTED PRIOR TO ASSEMBLY IF SASH IS TO BE FITTED INTO FRAME. FINPILE MUST NOT RUN BEHIND GLAZING BAR AND GAP MUST BE SEALED TO PREVENT WATER INFILTRATION.

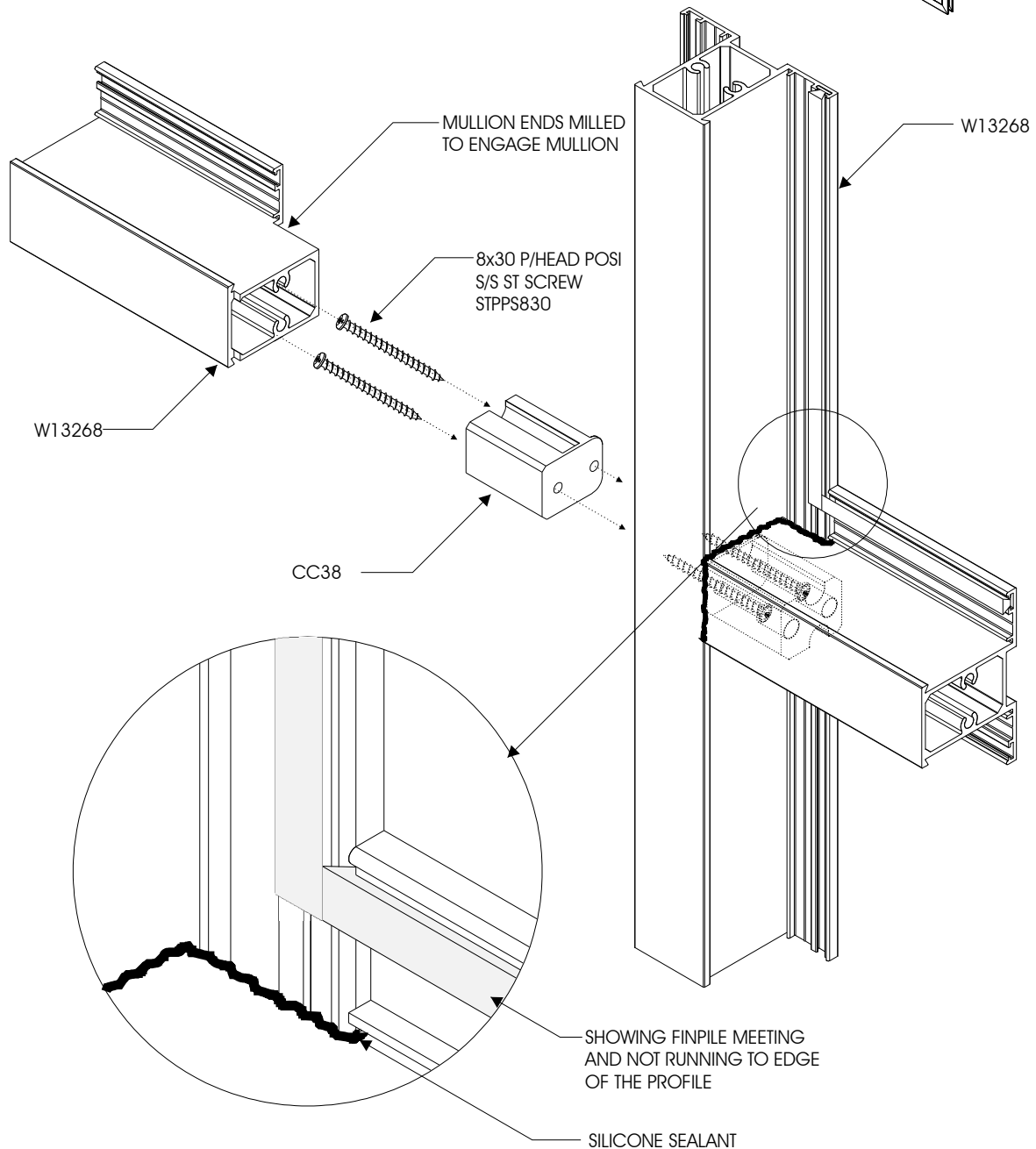
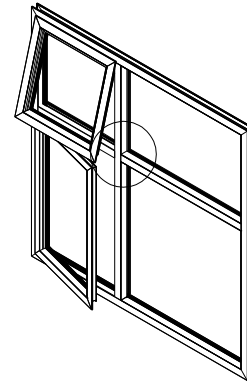

# CASEMENT 38 WINDOW GLAZING PROCEDURE



Insert the pull-in vinyl gasket into glazing beads by sliding or pressing it into the groove (1). Before cutting gasket, ensure that it has not stretched and cut 6mm longer so that corners are in compression at all times.

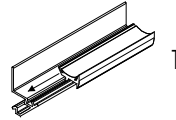

Position bottom glazing bead in glazing bead rebate (2).

Place glass on glazing blocks (3).

Insert top and then side glazing beads ensuring that they are in correctly.

Starting from top centre, insert roll in gasket (4) without stretching it (5). Stop 150mm from corner and partly cut gasket 6mm longer than the edge of the vertical bead. Insert gasket at corner and then roll in remaining 150mm. Repeat this on the other sides. Where gasket ends meet, cut gasket 6mm longer. Insert cut ends first and complete.

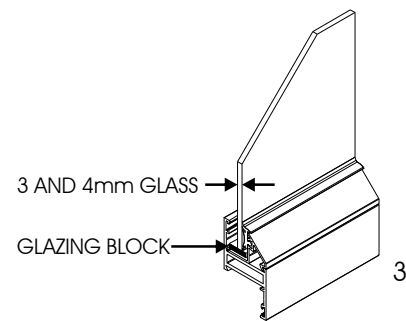
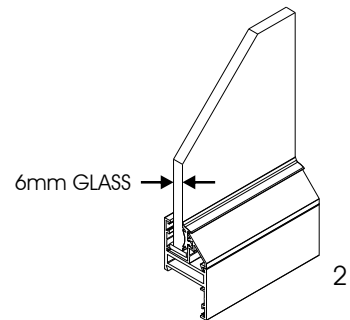

**ENSURE GASKETS ARE NOT STRETCHED AT ANY STAGE**

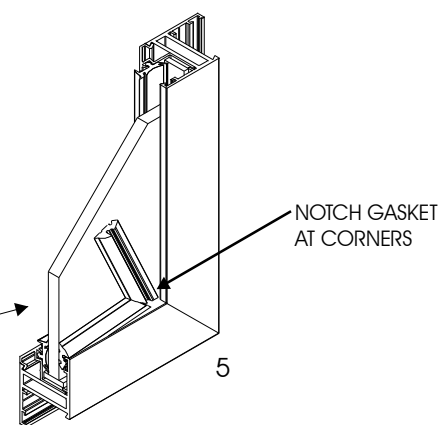
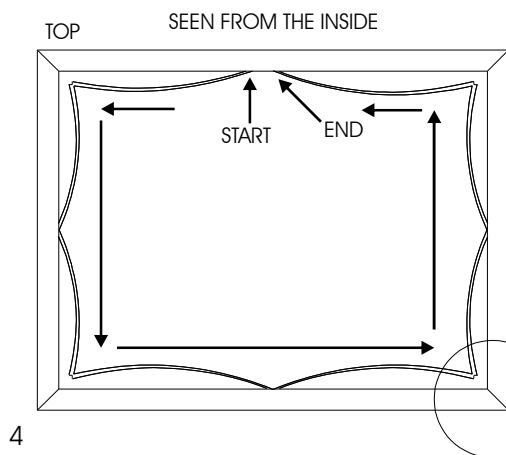

# CASEMENT 38 WINDOW GLAZING PROCEDURE



## GLAZING

### 1. SELECTION OF GLAZING METHODS

#### 1.1 SETTING AND LOCATION BLOCKS

Glass-to-metal contact must be avoided at all times by using setting and location blocks having a hardness of 50° to 90° shore A durometer. Use only blocks made of Neoprene, EPDM, Silicone or other elastomeric material.

Setting blocks are to have a minimum thickness of 3mm and must be at least 27mm in length per square metre of glass area.

The position of the setting and location blocks is illustrated in Figure 2.

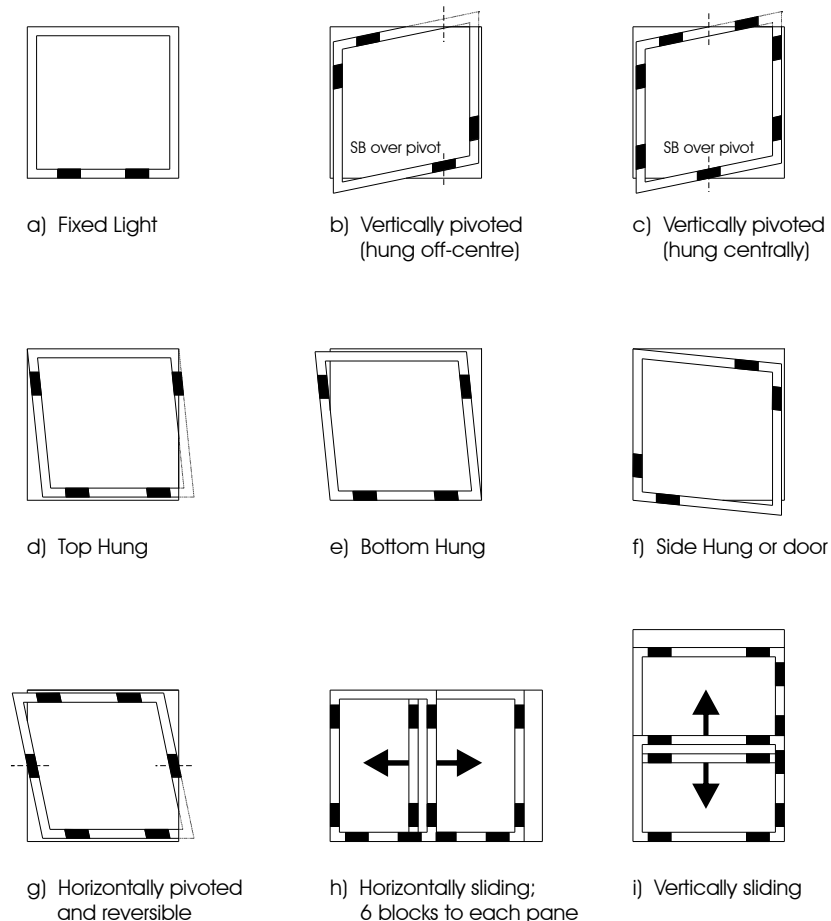
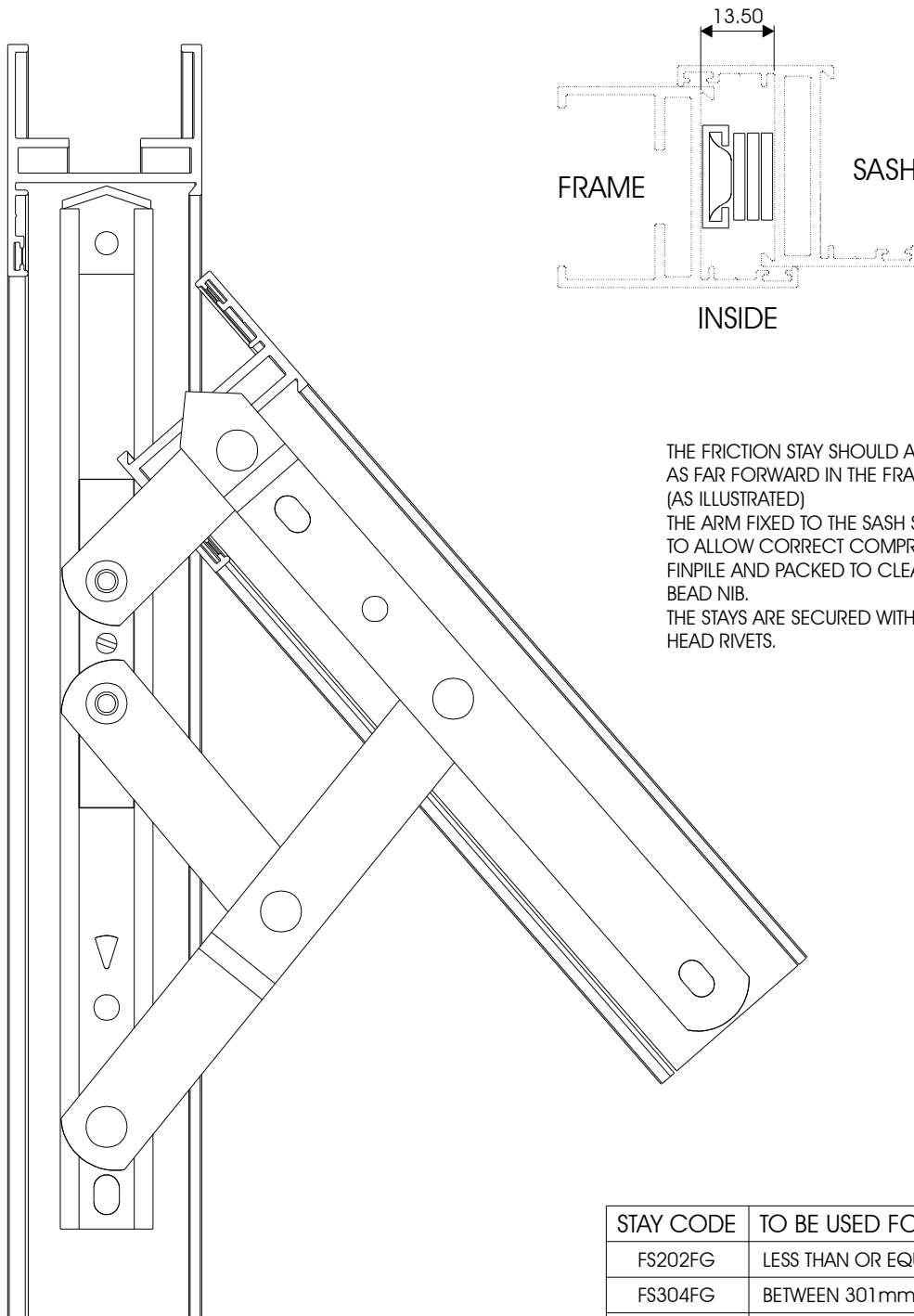

FIGURE 2 - POSITION OF SETTING AND LOCATION BLOCKS

CASEMENT 38  
 WINDOW  
 FRICTION STAY ASSEMBLY DETAIL



THE FRICTION STAY SHOULD ALWAYS BE FITTED AS FAR FORWARD IN THE FRAME AS POSSIBLE. (AS ILLUSTRATED)  
 THE ARM FIXED TO THE SASH SHOULD BE FITTED TO ALLOW CORRECT COMPRESSION OF THE FINPILE AND PACKED TO CLEAR GLAZING BEAD NIB.  
 THE STAYS ARE SECURED WITH 4.8 x 10 DOME HEAD RIVETS.

STAY CODE	TO BE USED FOR SASH SIZE
FS202FG	LESS THAN OR EQUAL TO 300mm
FS304FG	BETWEEN 301mm AND 450mm
FS406FG	BETWEEN 451mm AND 600mm
FS508FG	BETWEEN 601mm AND 750mm
FS600FG	GREATER THAN 750mm

CASEMENT 38  
WINDOW  
FIXING LUG PREPARATION PAGE



TWIST IN LUG FITTED TO  
EQUAL LEG OUTER FRAME

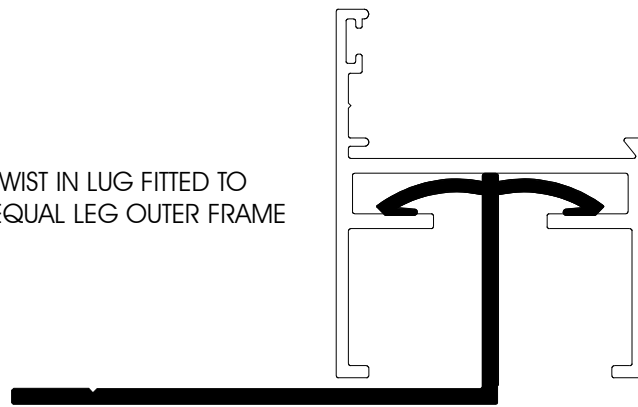

CASEMENT 38  
WINDOW  
HANDLE ASSEMBLY DETAIL

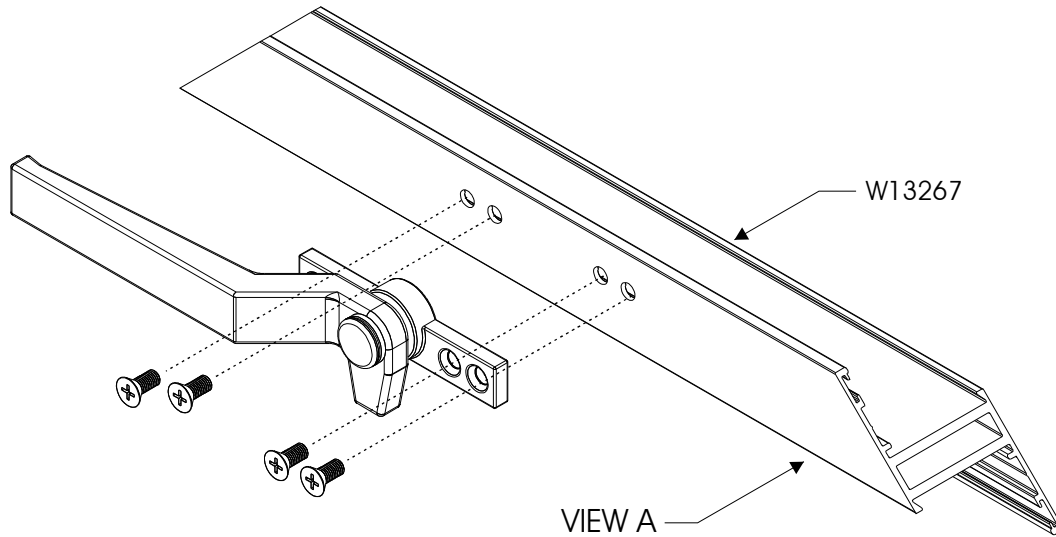

NO 8 x 10 COUNTERSUNK SELF-TAPPING  
FLAT END SCREWS

