

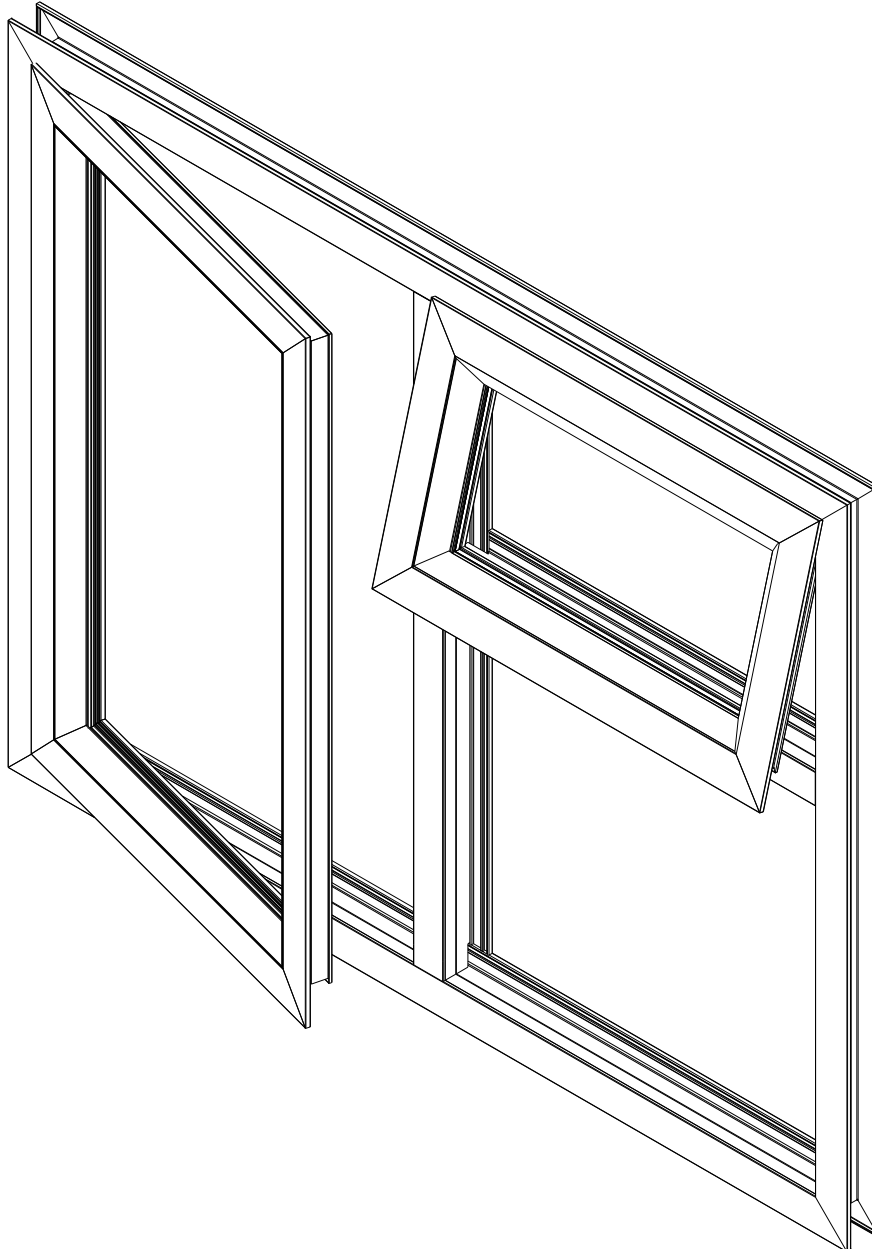

crealco | CASEMENT 30.5

CASEMENT 30.5 WINDOW



PRODUCT MANUAL

Disclaimer: The right to make alterations is reserved
© 2013 Wispeco (Pty) Ltd, All Rights Reserved
Revision: October 2013



Index

Legal Disclaimer	5
Profile Identification	6-8
Hardware Identification	9
New Crimper	10
Butterfly Gasket and Wedge Codes	11
Sash Limitation Charts	12
Standard Top Hung 600Pa Windload	13
Standard Top Hung 1000Pa Windload	14
Standard Top Hung 1500Pa Windload	15
Standard Side Hung 600Pa Windload	16
Standard Side Hung 1000Pa Windload	17
Standard Side Hung 1500Pa Windload	18
Standard Top Hung Window Typical Configurations	19
Standard Side Hung Window Typical Configurations	20
Cottage Pane Window Fixed Panel Typical Configurations	21
Cottage Pane Window Top & Side Hung Typical Configurations	22
Fixing Details	23
Typical Cross Sectional Detail Double Top Hung Over Fixed	24
Typical Cross Sectional Detail Side Hung Over Fixed	25
Cottage Pane Typical Cross Sectional Detail 2 x 2 Top Hung Over 2x1 Fixed Panel	26
Lite Window Typical Cross Sectional Detail Side Hung Over Fixed	27
Outer Frame Component Assembly Detail	28
Sash Frame Component Assembly Detail	29
Equal Leg Outer Frame Sill Level & Machining Detail	30
Unequal Leg Outer Frame Sill Level & Machining Detail	31
54mm Outer Frame Sill Level & Machining Detail	32
70mm Outer Frame Sill Level & Machining Detail	33
Lite Equal Leg Outer Frame Sill Level & Machining Detail	34
Standard Mullion Machining Detail For End Milling On Equal Leg Outer Frame	35
Standard Mullion Machining Detail For End Milling On Unequal Leg Outer Frame	36
Standard Mullion Machining Detail For End Milling On 54mm Outer Frame	37

This manual must be read in conjunction with the Installation, Cleaning and Maintenance Document, BEE Certificates and the Performance Certificates for the relevant system. The manual must also be used in conjunction with the design and cutting list from the latest version of StarFront.



Index

Standard Mullion Machining Detail For End Milling On 70mm Outer Frame	38
Standard Mullion Machining Detail For End Milling On Lite Equal Leg Outer Frame	39
Standard Transom With W/B Machining Detail For End Milling On Equal Leg Outer Frame	40
Standard Transom With W/B Machining Detail For End Milling On Unequal Leg Outer Frame	41
Standard Transom With W/B Machining Detail For End Milling On 54mm Outer Frame	42
Standard Transom With W/B Machining For End Milling On 70mm Outer Frame	43
Standard Transom With W/B Machining Detail For End Milling On Lite Equal Leg Outer Frame	44
54mm Mullion Machining Detail For End Milling On Equal Leg Outer Frame	45
54mm Mullion Machining Detail For End Milling On Unequal Leg Outer Frame	46
54mm Mullion Machining Detail For End Milling On 54mm Outer Frame	47
54mm Mullion Machining Detail For End Milling On 70mm Outer Frame	48
54mm Mullion Machining Detail For End Milling On Lite Equal Leg Outer Frame	49
70mm Mullion Machining Detail For End Milling On Equal Leg Outer Frame	50
70mm Mullion Machining Detail For End Milling On Unequal Leg Outer Frame	51
70mm Mullion Machining Detail For End Milling On 54mm Outer Frame	52
70mm Mullion Machining Detail For End Milling On 70mm Outer Frame	53
70mm Mullion Machining Detail For End Milling On Lite Equal Leg Outer Frame	54

This manual must be read in conjunction with the Installation, Cleaning and Maintenance Document, BEE Certificates and the Performance Certificates for the relevant system. The manual must also be used in conjunction with the design and cutting list from the latest version of StarFront.



Index

Cottage Pane Mullion Machining Detail For End milling On Equal Leg Outer Frame	55
Cottage Pane Mullion Machining Detail For End Milling On Unequal Leg Outer Frame	56
Cottage Pane Mullion Machining Detail For End Milling On 54mm Outer Frame	57
Cottage Pane Mullion Machining Detail For End Milling On 70mm Outer Frame	58
Cottage Pane Mullion Machining Detail For End Milling On Lite Equal Leg Outer Frame	59
Lite Mullion Machining Detail For End Milling On Equal Leg Outer Frame	60
Lite Mullion Machining Detail For End Milling On Unequal Leg Outer Frame	61
Lite Mullion Machining Detail For End Milling On 54mm Outer Frame	62
Lite Mullion Machining Detail For End Milling On 70mm Outer Frame	63
Lite Mullion Machining Detail For End Milling On Lite Equal Leg Outer Frame	64
Corner Cleat Assembly Detail For Tubular Sash	65
Corner Cleat Assembly Detail For Lite Tubular Sash	66
Glazing Bar Frame Joint Assembly Detail	67-68
Cross Joint Assembly Detail Standard Mullion	69
Cross Joint Assembly Detail Lite Mullion	70
Cross Joint Assembly Detail Cottage Pane Mullion	71
Glazing Procedure	72-73
Friction Assembly Detail	74
Handle Assembly Detail	75
Fixing Lug Preparation Detail	76

This manual must be read in conjunction with the Installation, Cleaning and Maintenance Document, BEE Certificates and the Performance Certificates for the relevant system. The manual must also be used in conjunction with the design and cutting list from the latest version of StarFront.



LEGAL DISCLAIMER

All information, recommendations or advice contained in this documentation is given in good faith to the best of Wispeco's knowledge and is based on current procedures in effect.

Since the actual use of this documentation by the user is beyond the control of Wispeco, such use is within the exclusive responsibility of the user. Wispeco cannot be held responsible for any loss incurred through incorrect or faulty use of this documentation.

Great care has been taken to ensure that the information provided is correct. Wispeco will accept no responsibility for any errors and/or omissions, which may have inadvertently occurred.

All mechanical joints must be sealed with a Wispeco approved joint sealer.

Laminated glass must not stand in water.

All drawings in the Wispeco Documentation are shown NOT to scale.

Wispeco cannot accept responsibility for the use of standard products since Wispeco does not know where these products are being installed.

The use of anti-magnetic stainless steel screws and pop rivets is recommended to reduce galvanic corrosion in harsh environments.

The hardware recommended in this documentation is suitable for use in most atmospheric environments. When hardware is used in severe coastal environments the manufacturer of the hardware must be consulted.

Fixing lugs on frames must be positioned as per the user manual and used in accordance to the AAAMSA specifications. When profiles are screwed together the screw centers must also be according to the user manual.

All glass used within Wispeco products must comply with SAGGA regulations.

By continuing to use this documentation you acknowledge that you understand and accept the legal disclaimer.

CASEMENT 30.5 WINDOW PROFILE IDENTIFICATION

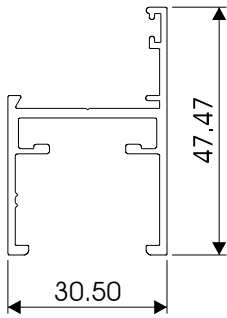

FRAME 30mm
EQ LEG STD
W27990

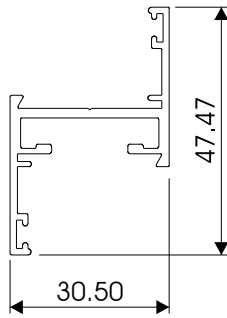

FRAME 30mm
UNEQ LEG STD
W27992

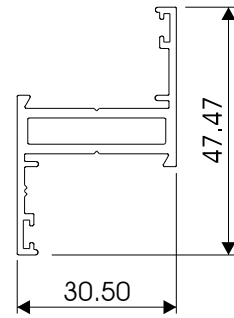

SASH TUBULAR
STANDARD
W53631

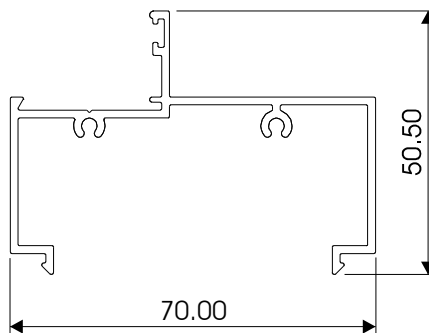

FRAME 70mm
W70968

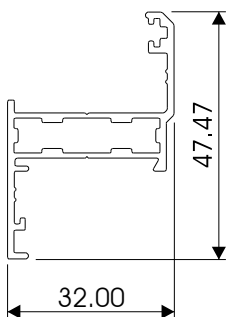

SASH
PICTURE FRAME
W55441

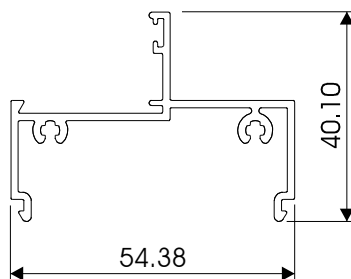

FRAME 54mm
W28481

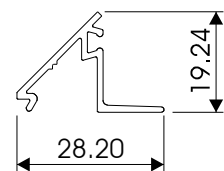

BEAD
4 & 5mm
W27991

CASEMENT 30.5 WINDOW PROFILE IDENTIFICATION

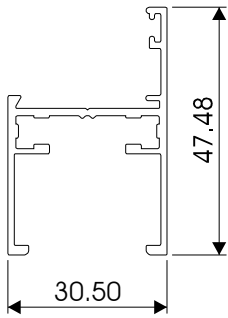

CAS30.5 FRAME 30mm
EQUAL LEG
W32028

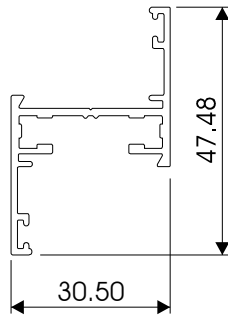

CAS30.5 FRAME 30mm
UNEQUAL LEG
W32027

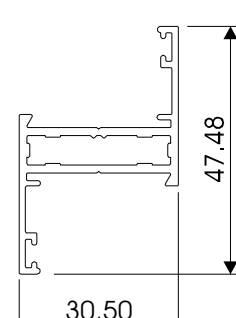

CAS30.5 SASH TUBULAR
W55684

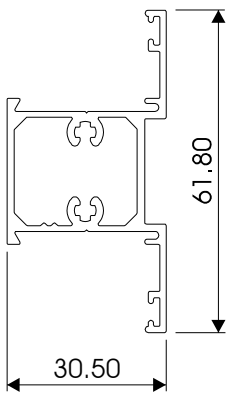

CAS30.5 MULLION 30mm
W55685

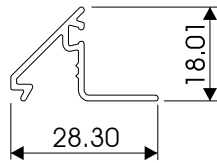

CAS30.5 BEAD MULTI
13mm GAP
W31139

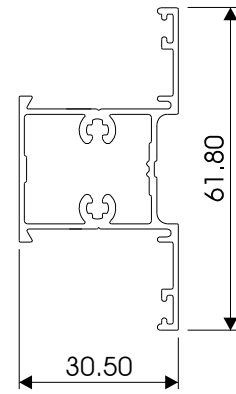

CAS30.5 MULLION 30mm
ECONO
W55008

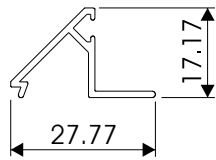

CAS30.5 BEAD 6mm
W28325

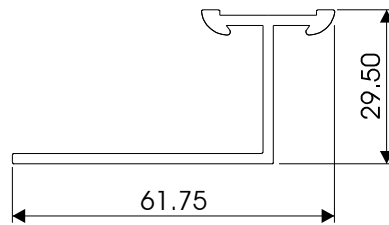

CAS30.5 FIXING LUG
TWIST IN
W28002

CASEMENT 30.5 WINDOW PROFILE IDENTIFICATION

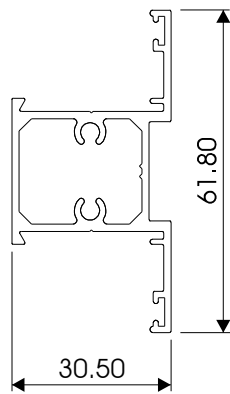

CAS30.5 MULLION 30mm
STANDARD
W53629

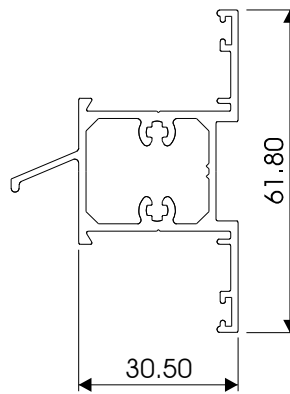

CAS30.5 MULLION 30mm
WEATHER BAR
W53630

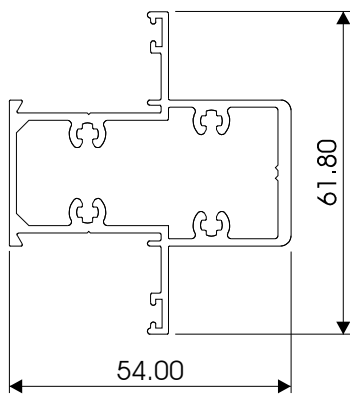

CAS30.5 MULLION 54mm
W54651

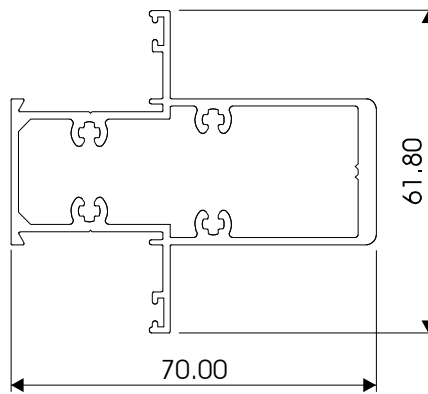

CAS30.5 MULLION 70mm
W54652

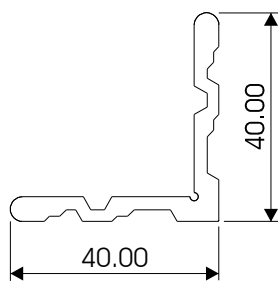

CAS30.5 CORNER CLEAT
40mm
W27989

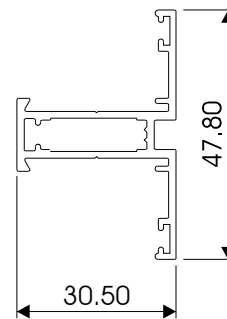

CAS30.5 MULLION 30mm
COTTAGE PANE
W54867

CASEMENT 30.5 WINDOW HARDWARE IDENTIFICATION

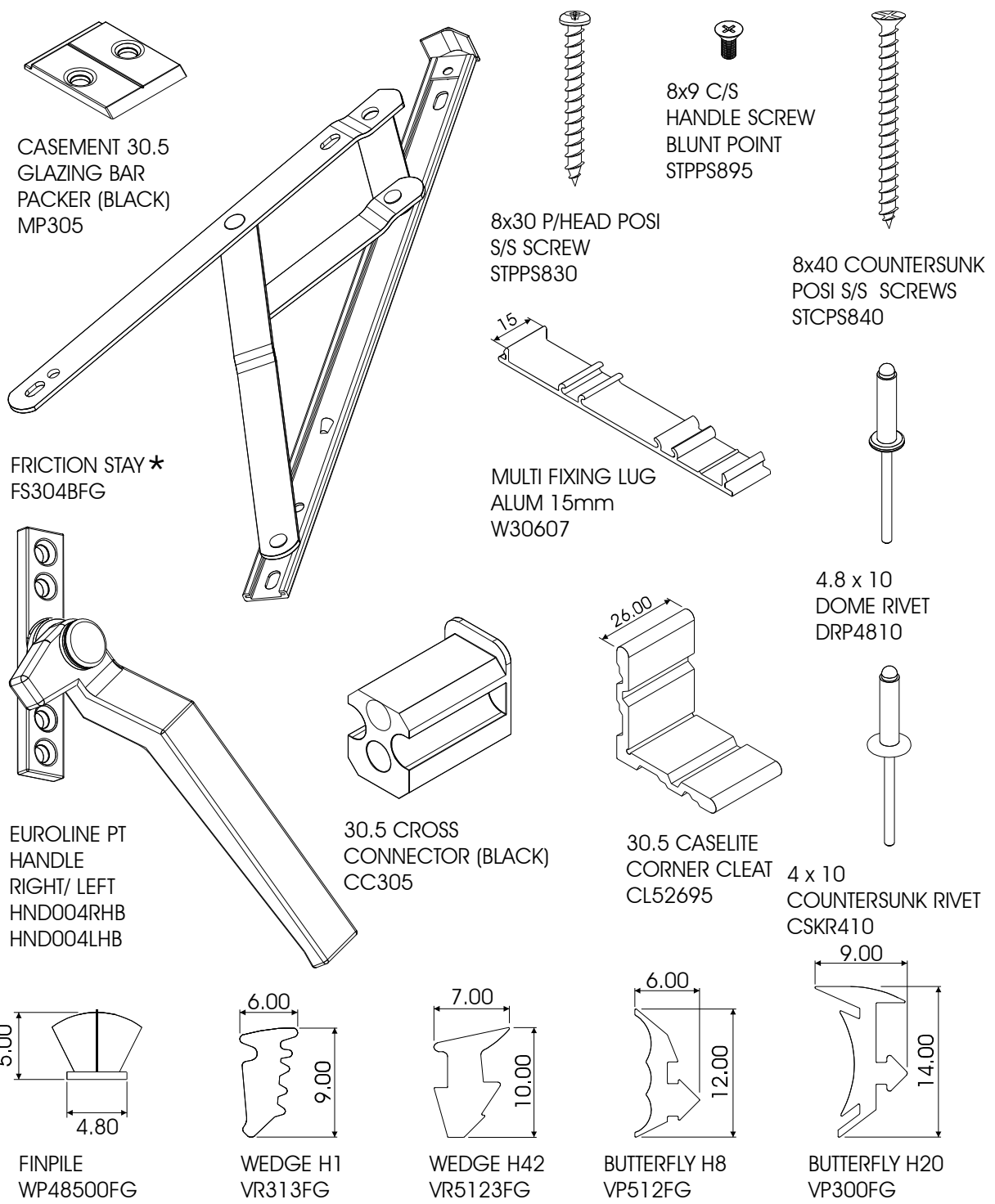

*** MAINTENANCE OF STAINLESS STEEL FRICTION STAYS**

To preserve the appearance and prevent corrosion, wipe down Friction Stays with warm water and a mild detergent. For stubborn dirt or stains, use a non corrosive cleaner, for more aggressive stains add a small amount of vinegar to water. Carbon steel brushes and steel wool should be avoided as they may leave particles embedded in the surface which may lead to rusting. After cleaning rinse with hot water and dry using a clean cloth. Cleaning is recommended once a month or more frequently when subjected to regular use or heavy soiling.



CASEMENT 30.5 WINDOW NEW CRIMPER

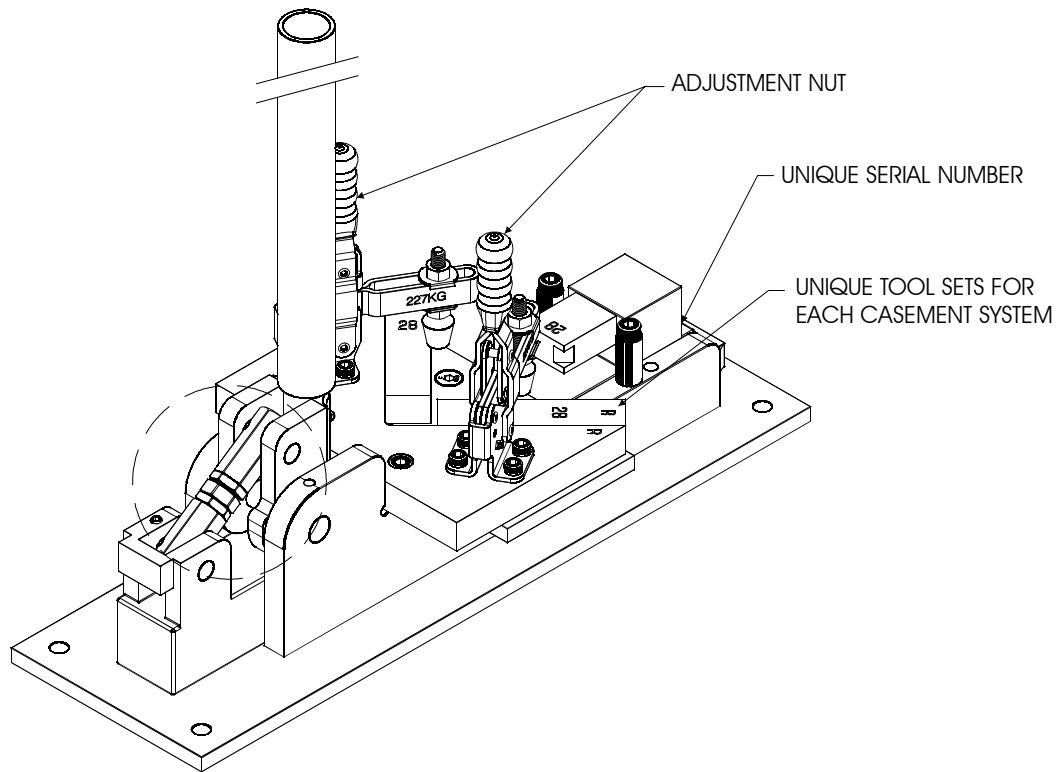

BENEFITS OF THE NEW CRIMPER:

- Double Toggle Clamps for better alignment of profiles.
- Simple & Quick precision adjustment to set profile crimping pressure.
- Unique multiple toolsets to cater for each casement system to ensure accurate crimping.
- Comprehensive manual available with crimper.
- Each crimper has a unique serial number for ease of maintenance.

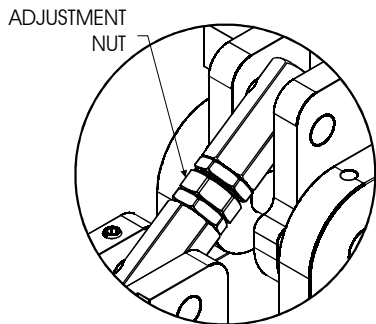

FOR QUICK & EASY CRIMPING PRESSURE SETTING
ADJUSTMENTS ARE DONE JUST BY TURNING THE NUT.

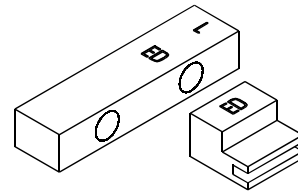

THE UNIQUE TOOL SETS FOR EACH SYSTEM AVAILABLE
SEPARATELY ALLOWS FOR ACCURATE CRIMPING.

THE NEW CRIMPER IS NOW AVAILABLE AT YOUR LOCAL STOCKIST

CASEMENT 30.5
 WINDOW
 BUTTERFLY GASKET AND
 WEDGE CODES



BUTTERFLY GASKET

●-B01O

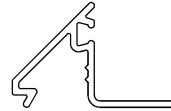

W31139 BEAD



●-W01G

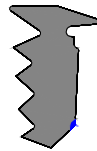

●-W02B

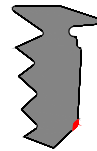

●-W03R

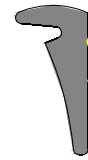

●-W04Y

WEDGES

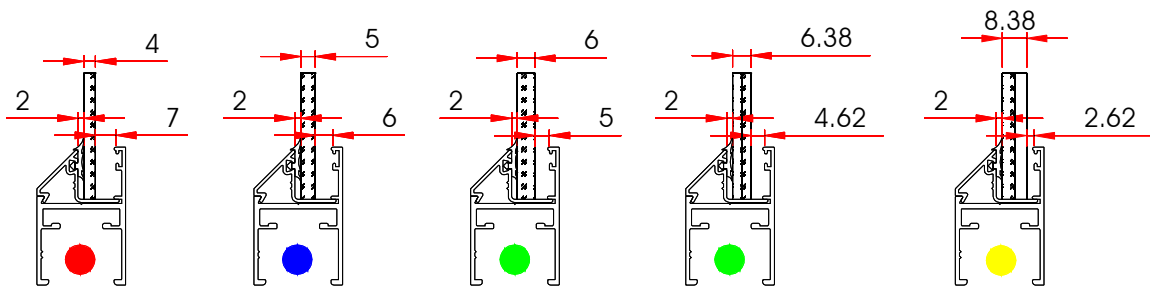

CASEMENT 30.5 WITH W31139 BEAD

CASEMENT 30.5
WINDOW
SASH LIMITATION CHARTS



		Maximum Vent Width in mm	Maximum Vent Height in mm
Top Hung	W53631	1000	750

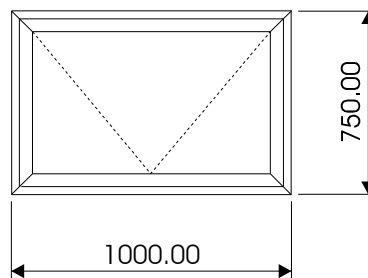

		Maximum Vent Width in mm	Maximum Vent Height in mm
Side Hung	W53631	600	1200

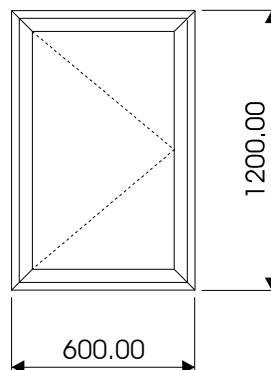

CASEMENT 30.5 WINDOW STANDARD TOP HUNG 600Pa WINDLOAD



NOTE:

1. SEE THE MULLION LIMITATION CHART
2. OPENING SIZES SHOWN IN RED
3. ACTUAL WINDOW SIZES SHOWN IN BLACK AND BRACKETS.

	600 (590)	900 (890)	1 200 (1190)	1 500 (1490)	1 800 (1790)	2 400 (2390)
600 (590)	 30.5-0606T	 30.5-0906T	 30.5-1206T	 30.5-1506T	 30.5-1806TT	 30.5-2406TT
900 (890)	 30.5-0609T	 30.5-0909T	 30.5-1209T	 30.5-1509T	 30.5-1809TT	 30.5-2409TT
1200 (1190)	 30.5-0612T	 30.5-0912T	 30.5-1212DT	 30.5-1512DT	 30.5-1812DT	 30.5-2412DT
1500 (1490)	 30.5-0615DT	 30.5-0915DT	 30.5-1215DT 54mm Mullion W54651	 30.5-1515DT 54mm Mullion W54651	 30.5-1815DT 54mm Mullion W54651	 30.5-2415DT 54mm Mullion W54651
1800 (1790)	 30.5-0618DT	 30.5-0918DT	 30.5-1218DT 54mm Mullion W54651	 30.5-1518DT 54mm Mullion W54651	 30.5-1818DT 54mm Mullion W54651	 30.5-2418DT 54mm Mullion W54651

CASEMENT 30.5 WINDOW STANDARD TOP HUNG 1000Pa WINDLOAD



NOTE:

1. SEE THE MULLION LIMITATION CHART
2. OPENING SIZES SHOWN IN RED
3. ACTUAL WINDOW SIZES SHOWN IN BLACK AND BRACKETS.

	600 (590)	900 (890)	1 200 (1190)	1 500 (1490)	1 800 (1790)	2 400 (2390)
600 (590)	 30.5 -0606T	 30.5 -0906T	 30.5 -1206T	 30.5 -1506T	 30.5 -1806T	 30.5 -2406T
900 (890)	 30.5 -0609T	 30.5 -0909T	 30.5 -1209T	 30.5 -1509T	 30.5 -1809T	 30.5 -2409T
1200 (1190)	 30.5 -0612T	 30.5 -0912T	 30.5 -1212DT	 30.5 -1512DT 54mm Mull W54651	 30.5 -1812DT 54mm Mull W54651	 30.5 -2412DT 54mm Mull W54651
1500 (1490)	 30.5 -0615DT	 30.5 -0915DT	 30.5 -1215DT 54mm Mull W54651	 30.5 -1515DT 54mm Mull W54651	 30.5 -1815DT 54mm Mull W54651	 30.5 -2415DT 54mm Mull W54651
1800 (1790)	 30.5 -0618DT	 30.5 -0918DT	 30.5 -1218DT 54mm Mull W54651	 30.5 -1518DT 54mm Mull W54652	 30.5 -1818DT 54mm Mull W54652	 30.5 -2418DT 54mm Mull W54652

CASEMENT 30.5 WINDOW STANDARD TOP HUNG 1500Pa WINDLOAD



NOTE:

1. SEE THE MULLION LIMITATION CHART
2. OPENING SIZES SHOWN IN RED
3. ACTUAL WINDOW SIZES SHOWN IN BLACK AND BRACKETS.

	600 (590)	900 (890)	1 200 (1190)	1 500 (1490)	1 800 (1790)	2 400 (2390)
600 (590)	 30.5 -0606T	 30.5 -0906T	 30.5 -1206T	 30.5 -1506T	 30.5 -1806TT	 30.5 -2406TT
900 (890)	 30.5 -0609T	 30.5 -0909T	 30.5 -1209T	 30.5 -1509T	 30.5 -1809TT	 30.5 -2409TT
1200 (1190)	 30.5 -0612T	 30.5 -0912T	 30.5 -1212DT 54mm Mullion W54651	 30.5 -1512DT 54mm Mullion W54651	 30.5 -1812DT 54mm Mullion W54651	 30.5 -2412DT 54mm Mullion W54651
1500 (1490)	 30.5 -0615DT	 30.5 -0915DT	 30.5 -1215DT 54mm Mullion W54651	 30.5 -1515DT 54mm Mullion W54651	 30.5 -1815DT 70mm Mullion W54652	 30.5 -2415DT 70mm Mullion W54652
1800 (1790)	 30.5 -0618DT	 30.5 -0918DT	 30.5 -1218DT 70mm Mullion W54652	 30.5 -1518DT 70mm Mullion W54652	 30.5 -1818DT 70mm Mullion W54652	 30.5 -2418DT 70mm Mullion W54652

CASEMENT 30.5 WINDOW STANDARD SIDE HUNG 600Pa WINDLOAD



NOTE:

1. SEE THE MULLION LIMITATION CHART
2. OPENING SIZES SHOWN IN RED
3. ACTUAL WINDOW SIZES SHOWN IN BLACK AND BRACKETS.

	600 (590)	900 (890)	1 200 (1190)	1 500 (1490)	1 800 (1790)	2 400 (2390)
600 (590)	 305 -0609S	 305 -0909S	 305 -1209S	 305 -1509S	 305 -1809SS	 305 -2409SS
900 (890)	 305 -0612S	 305 -0912S	 305 -1212S	 305 -1512S	 305 -1812SS	 305 -2412SS
1200 (1190)	 305 -0615S	 305 -0915S	 305 -1215S	 305 -1515S	 305 -1815SS	 305 -2415SS
1500 (1490)	 305 -0618S	 305 -0918S	 305 -1218S	 305 -1518S	 305 -1818SS	 305 -2418SS
1800 (1790)	 305 -0618S	 305 -0918S	 305 -1218S	 305 -1518S	 305 -1818SS	 305 -2418SS

CASEMENT 30.5 WINDOW STANDARD SIDE HUNG 1000Pa WINDLOAD



NOTE:

1. SEE THE MULLION LIMITATION CHART
2. OPENING SIZES SHOWN IN RED
3. ACTUAL WINDOW SIZES SHOWN IN BLACK AND BRACKETS.

	600 (590)	900 (890)	1 200 (1190)	1 500 (1490)	1 800 (1790)	2 400 (2390)
600 (590)	 305 -0609S	 305 -0909S	 305 -1209S	 305 -1509S	 305 -1809SS	 305 -2409SS
900 (890)	 305 -0612S	 305 -0912S	 305 -1212S	 305 -1512S	 305 -1812SS	 305 -2412SS
1200 (1190)	 305 -0615S	 305 -0915S	 305 -1215S	 305 -1515S	 305 -1815SS	 305 -2415SS
1500 (1490)	 305 -0618S	 305 -0918S	 305 -1218S	 305 -1518S	 305 -1818SS	 305 -2418SS
1800 (1790)						

CASEMENT 30.5 WINDOW STANDARD SIDE HUNG 1500Pa WINDLOAD



NOTE:

1. SEE THE MULLION LIMITATION CHART
2. OPENING SIZES SHOWN IN RED
3. ACTUAL WINDOW SIZES SHOWN IN BLACK AND BRACKETS.

	600 (590)	900 (890)	1 200 (1190)	1 500 (1490)	1 800 (1790)	2 400 (2390)
600 (590)	 305 -0609S	 305 -0909S	 305 -1209S	 305 -1509S 54mm Mullion W54651	 305 -1809SS	 305 -2409SS 54mm Mullion W54651
900 (890)	 305 -0612S	 305 -0912S 54mm Mullion W54651	 305 -1212S 54mm Mullion W54651	 305 -1512S 54mm Mullion W54651	 305 -1812SS 54mm Mullion W54651	 305 -2412SS 54mm Mullion W54651
1200 (1190)	 305 -0615S	 305 -0915S 54mm Mullion W54651	 305 -1215S 54mm Mullion W54651	 305 -1515S 54mm Mullion W54651	 305 -1815SS 54mm Mullion W54651	 305 -2415SS 70mm Mullion W54652
1500 (1490)	 305 -0618S	 305 -0918S 70mm Mullion W54652	 305 -1218S 70mm Mullion W54652	 305 -1518S 70mm Mullion W54652	 305 -1818SS 70mm Mullion W54652	 305 -2418SS 70mm Mullion W54652
1800 (1790)						

CASEMENT 30.5
WINDOW
STANDARD TOP HUNG WINDOW
TYPICAL CONFIGURATIONS

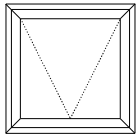

A

SINGLE TOP HUNG

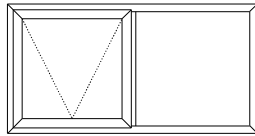

BB

TOP HUNG
NEXT TO FIXED

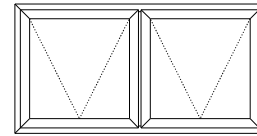

CC

TOP HUNG NEXT
TO TOP HUNG

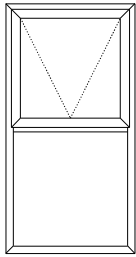

B

TOP HUNG
OVER FIXED

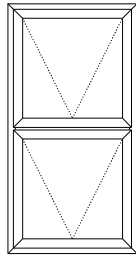

C

TOP HUNG
OVER TOP HUNG

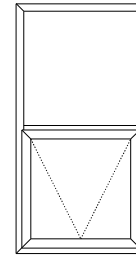

E

FIXED OVER
TOP HUNG

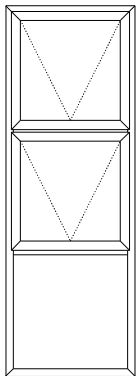

D

DOUBLE TOP HUNG
OVER FIXED

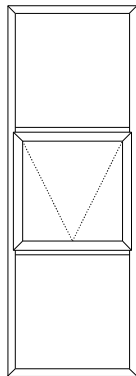

DD

FIXED OVER
TOP HUNG
OVER FIXED

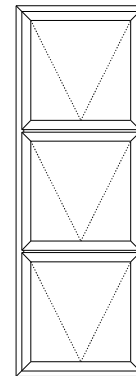

EE

TRIPLE TOP HUNG

CASEMENT 30.5
WINDOW
STANDARD SIDE HUNG WINDOW
TYPICAL CONFIGURATIONS

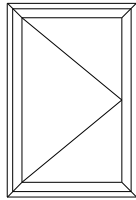

A
SINGLE SIDE HUNG

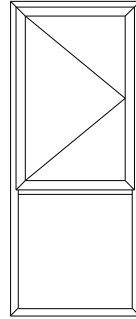

B
SIDE HUNG
OVER FIXED

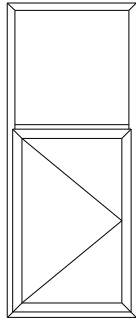

C
FIXED OVER
SIDE HUNG

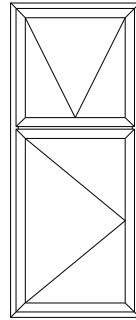

D
TOP HUNG
OVER SIDE HUNG

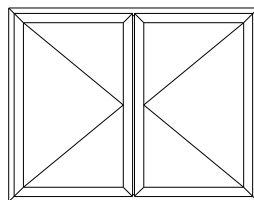

CC
SIDE HUNG NEXT
TO SIDE HUNG

CASEMENT 30.5
WINDOW
COTTAGE PANE WINDOW
FIXED PANEL TYPICAL CONFIGURATIONS

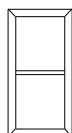

A

1 x 2 FIXED PANEL



B

1 x 3 FIXED PANEL

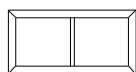

C

2 x 1 FIXED PANEL

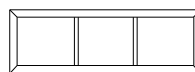

D

3 x 1 FIXED PANEL

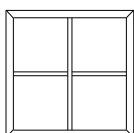

E

2 x 2 FIXED PANEL

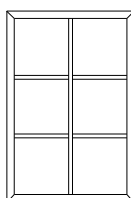

F

2 x 3 FIXED PANEL

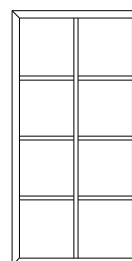

G

2 x 4 FIXED PANEL

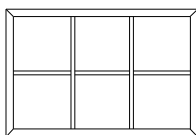

H

3 x 2 FIXED PANEL

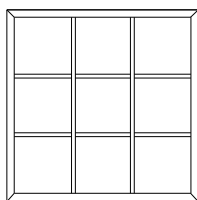

I

3 x 3 FIXED PANEL

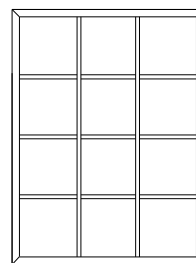

J

3 x 4 FIXED PANEL

CASEMENT 30.5
WINDOW
COTTAGE PANE WINDOW
TOP HUNG & SIDE HUNG
TYPICAL CONFIGURATIONS



TOP HUNG

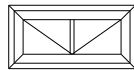

P

2 x 1 PANE
SINGLE TOP HUNG

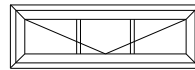

R

3 x 1 PANE
SINGLE TOP HUNG

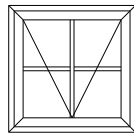

Q

2 x 2 PANE
SINGLE TOP HUNG

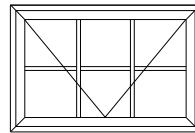

S

3 x 2 PANE
SINGLE TOP HUNG

SIDE HUNG

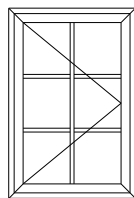

P

2 x 3 PANE
SINGLE SIDE HUNG

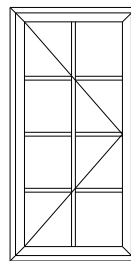

Q

2 x 4 PANE
SINGLE SIDE HUNG

CASEMENT 30.5 WINDOW FIXING DETAILS

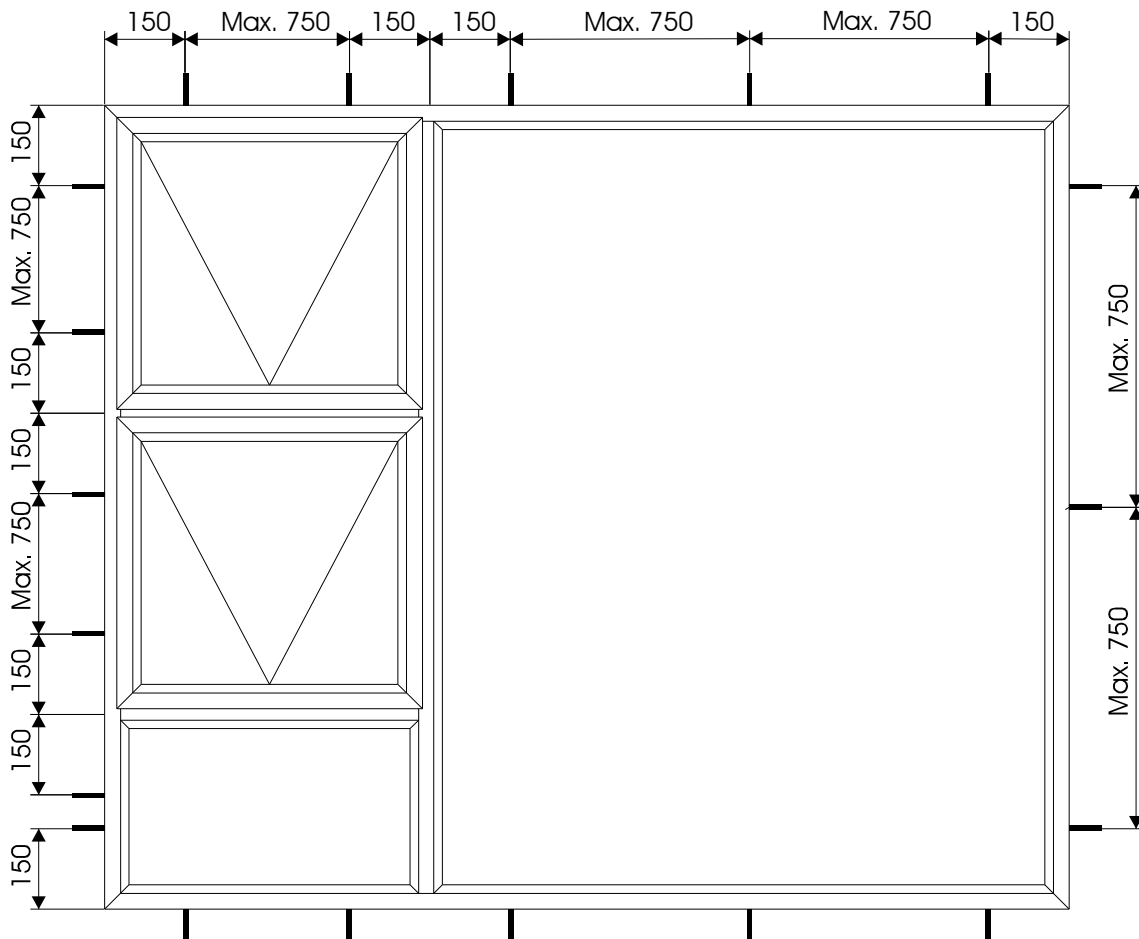
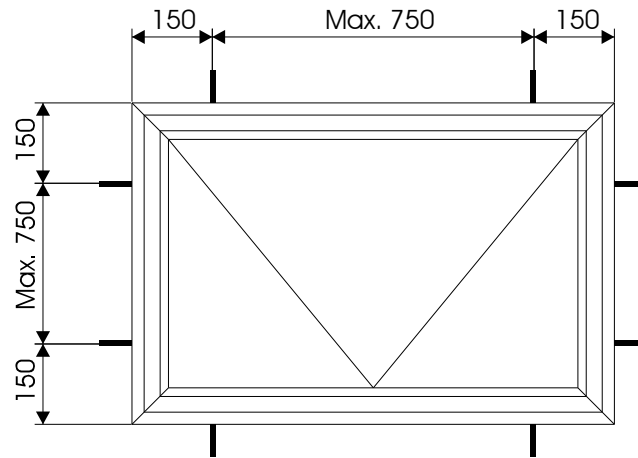

General:

The window is fixed into position - the sill is then built at a later stage - the bottom lugs can be left in place but it is often found that most times the mason either bends them out of his way or breaks them off. This practically means that most windows are only secured on 3 sides.

CASEMENT 30.5
 WINDOW
 TYPICAL CROSS SECTIONAL DETAIL
 DOUBLE TOP HUNG OVER FIXED

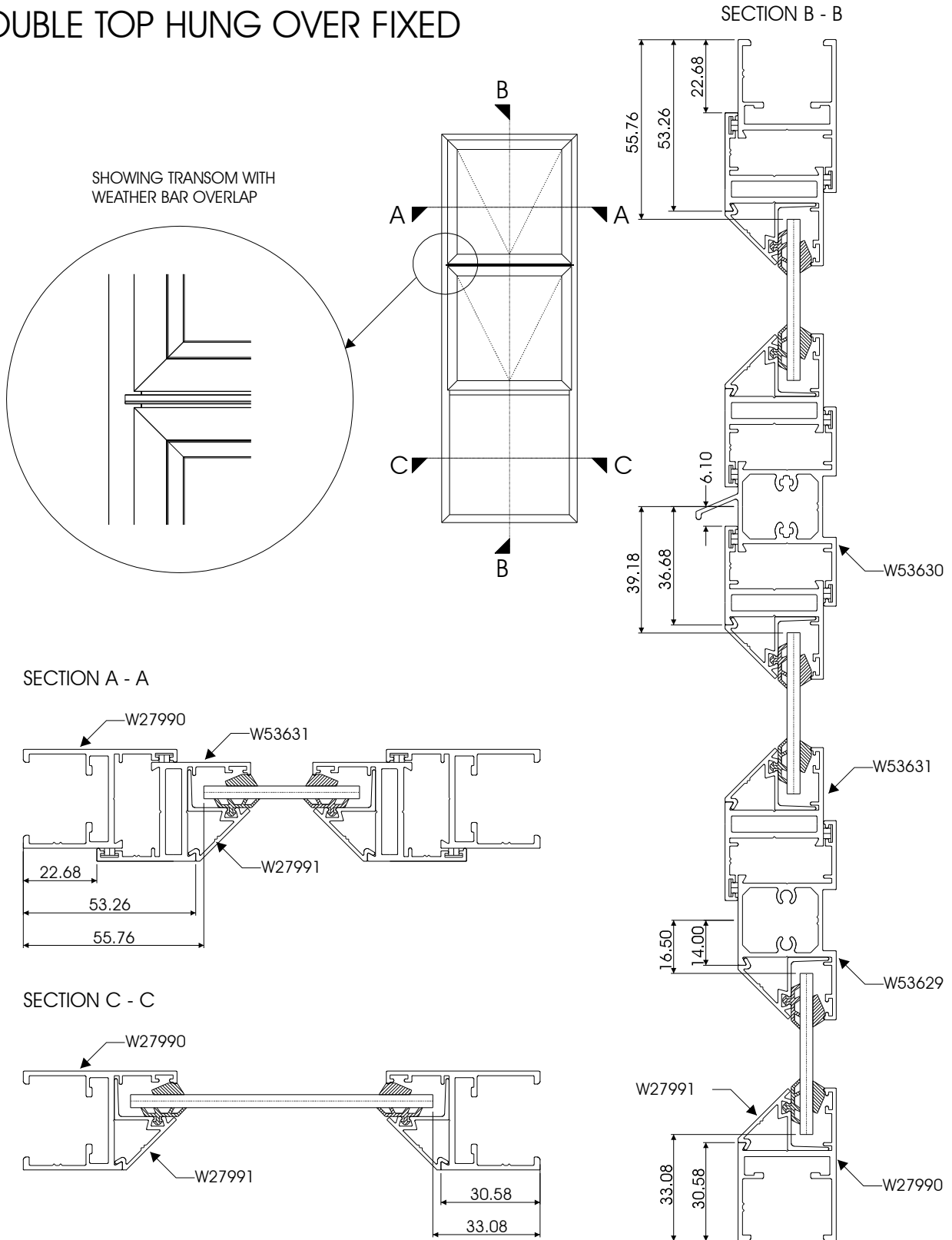

CASEMENT 30.5
 WINDOW
 TYPICAL CROSS SECTIONAL DETAIL
 SIDE HUNG OVER FIXED

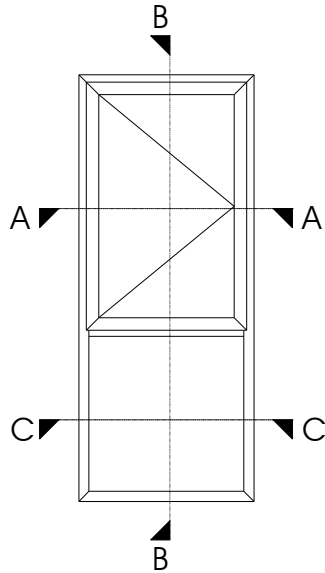

SECTION B - B

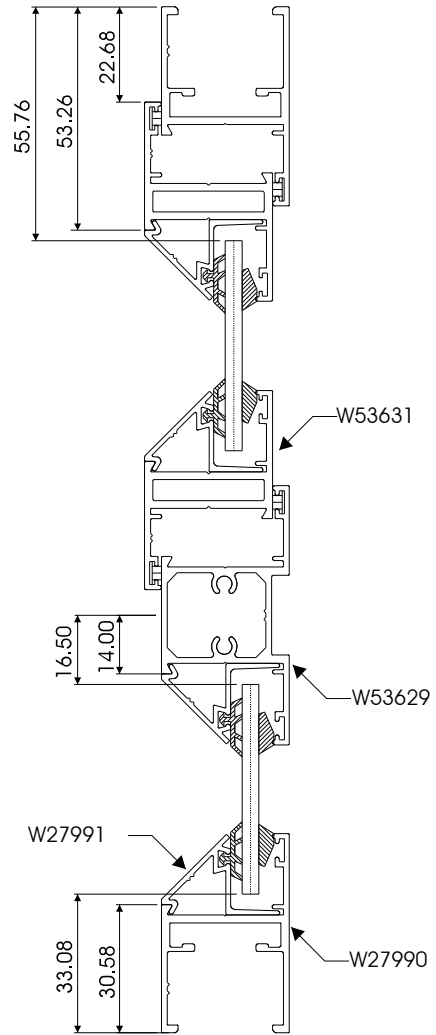

SECTION A - A

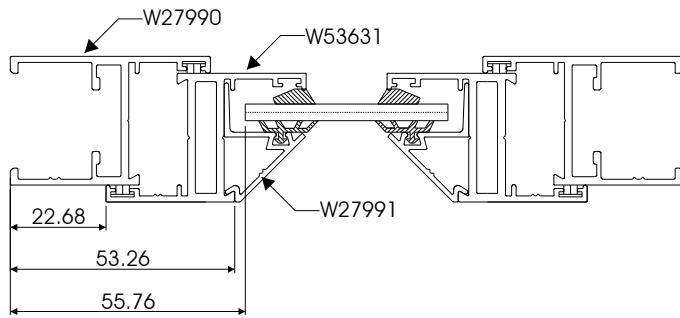

SECTION C - C

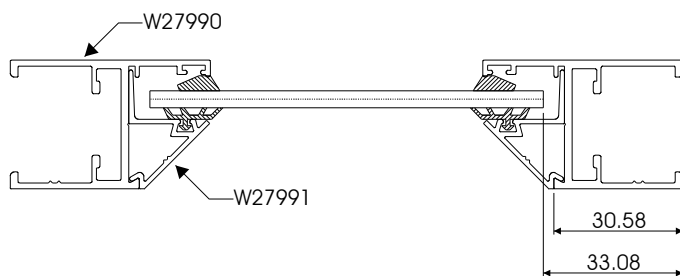

CASEMENT 30.5
 WINDOW
 COTTAGE PANE TYPICAL
 CROSS SECTIONAL DETAIL
 2 x 2 TOP HUNG OVER
 2 x 1 FIXED PANEL

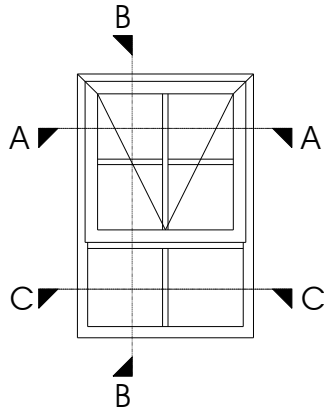

SECTION B - B

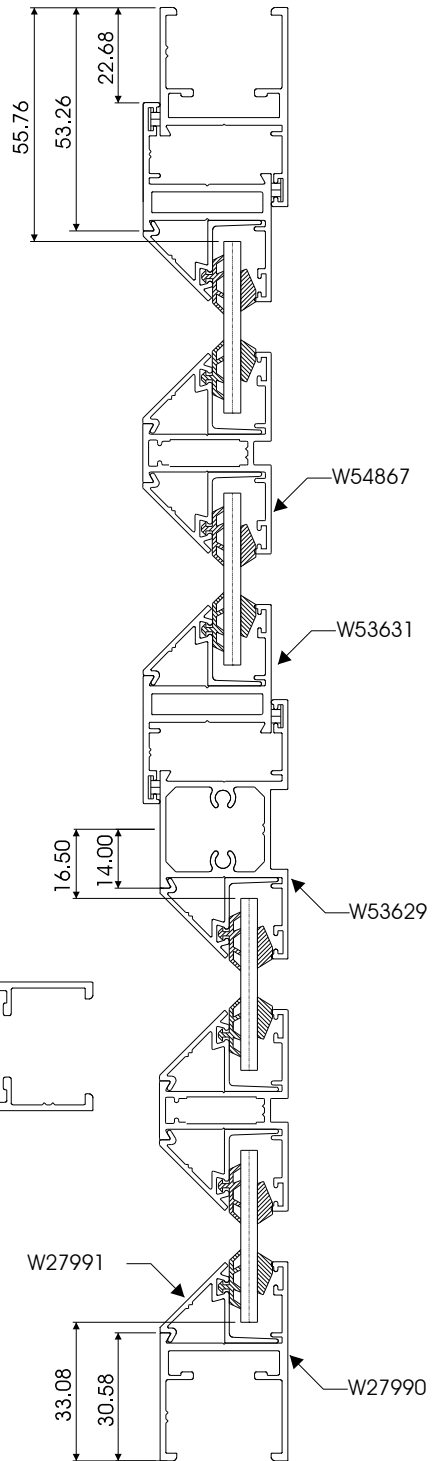

SECTION A - A

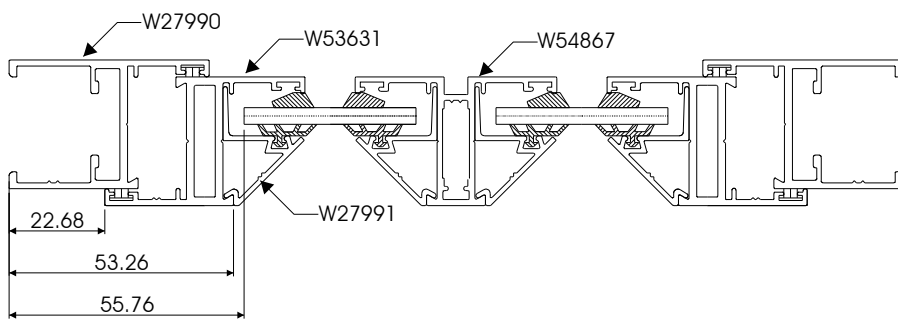

SECTION C - C

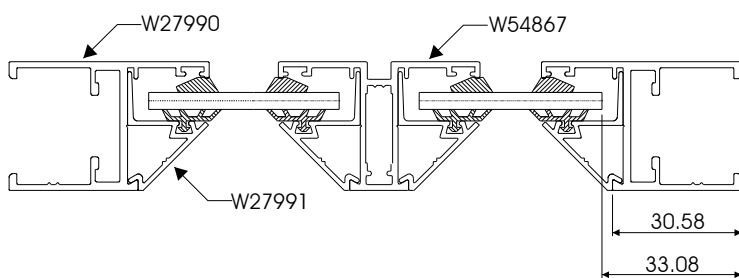

CASEMENT 30.5
 WINDOW
 LITE TYPICAL CROSS SECTIONAL DETAIL
 SIDE HUNG OVER FIXED

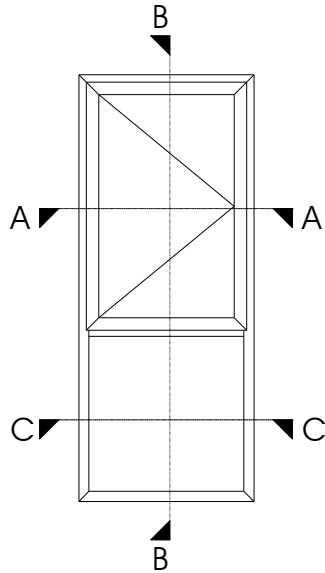

SECTION B - B

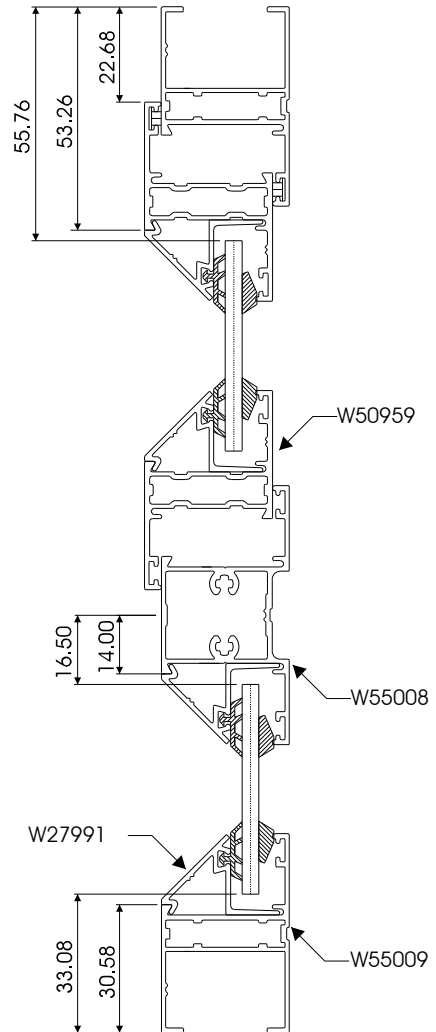

SECTION A - A

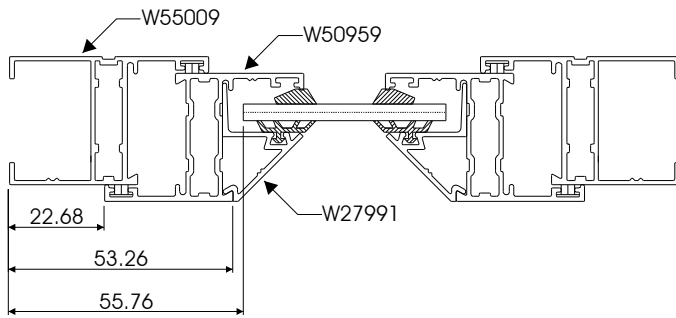

SECTION C - C

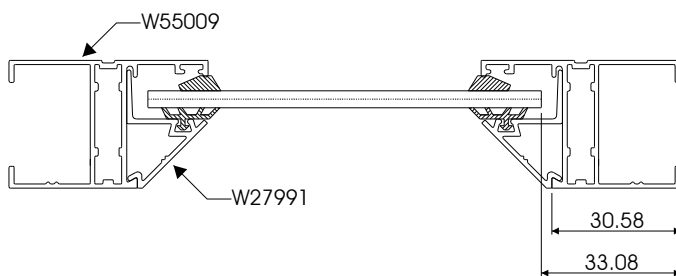

CASEMENT 30.5 WINDOW OUTER FRAME COMPONENT ASSEMBLY DETAIL

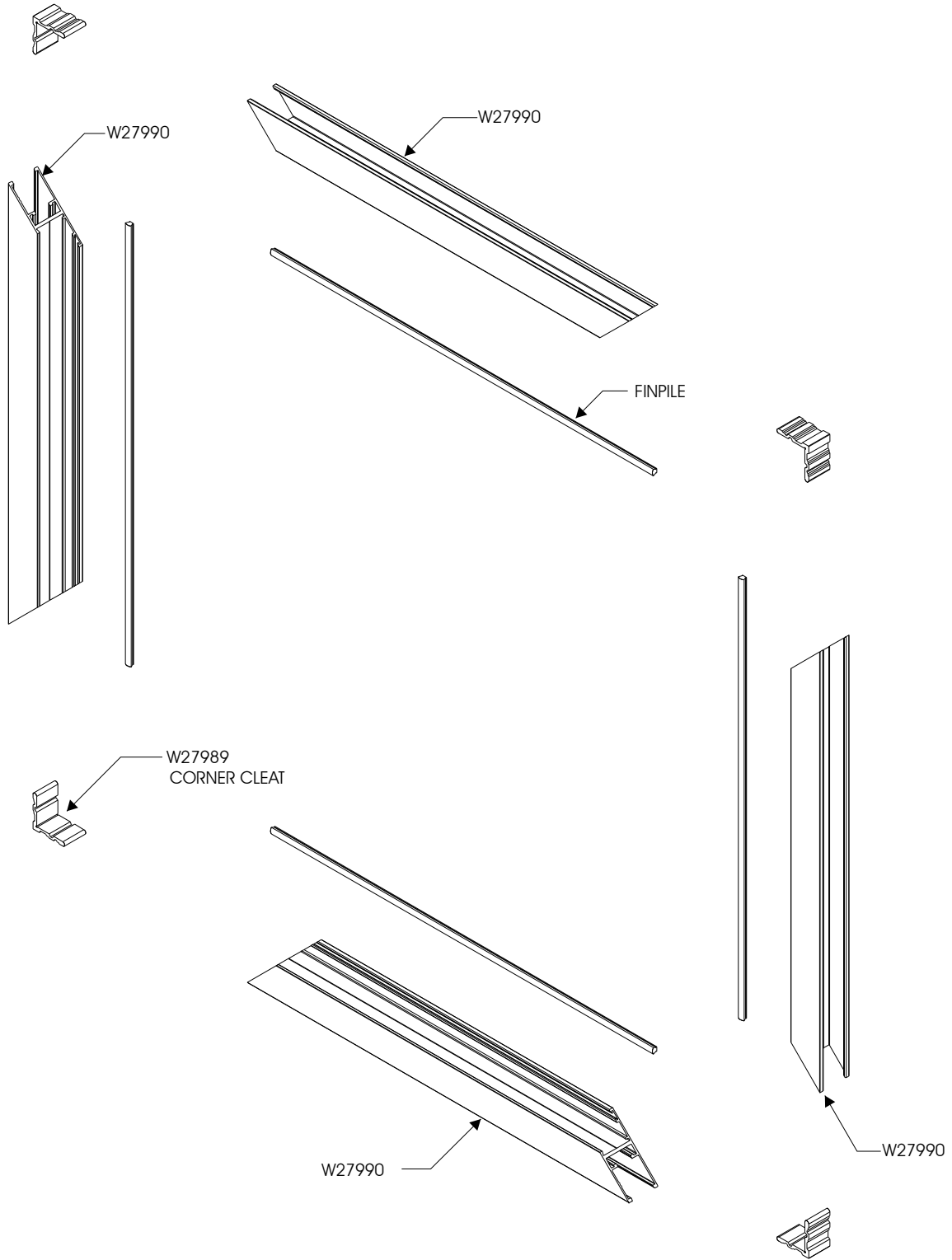

CASEMENT 30.5
WINDOW
SASH FRAME COMPONENT
ASSEMBLY DETAIL

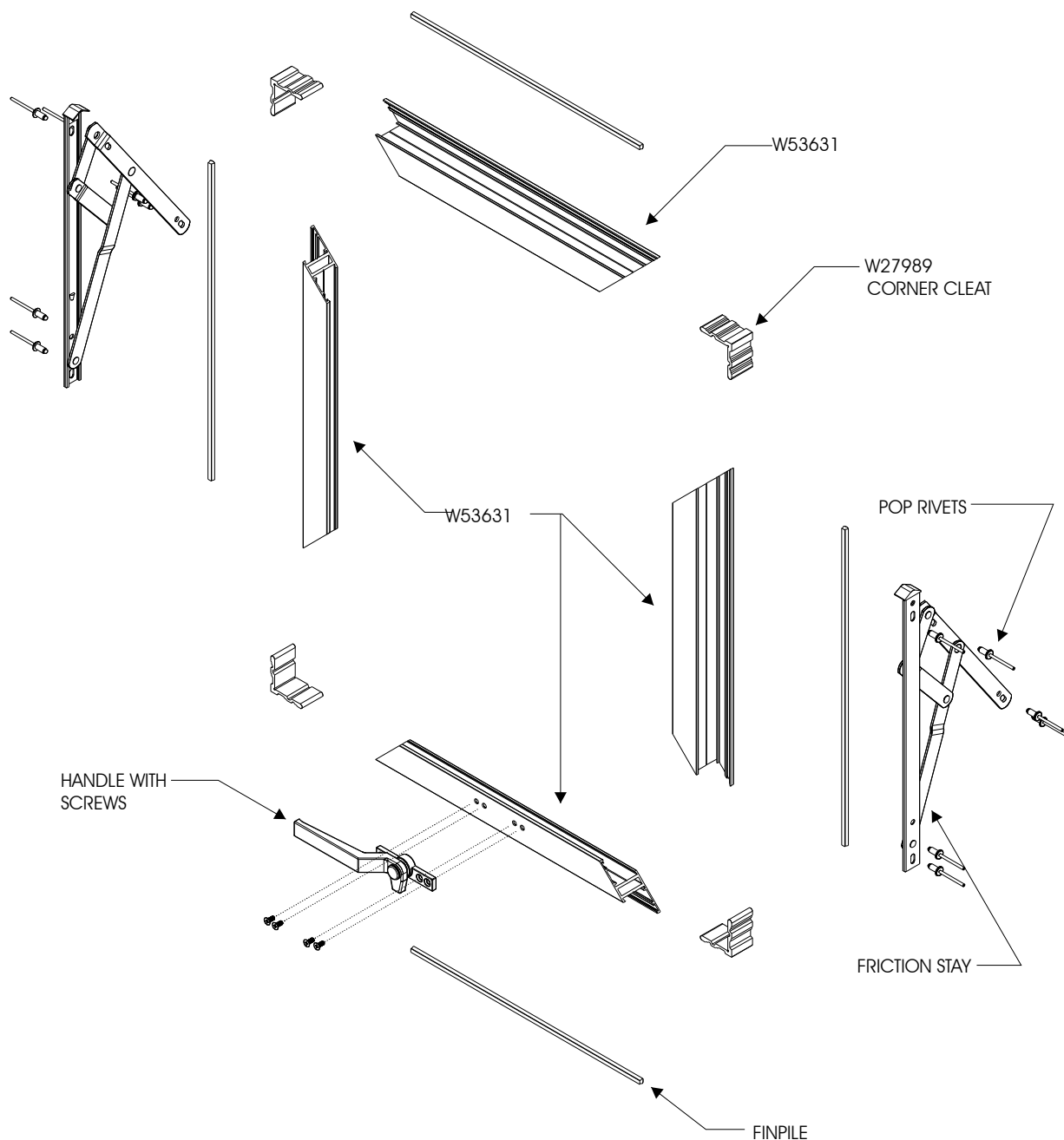

CASEMENT 30.5
WINDOW
EQUAL LEG OUTER FRAME
SILL LEVEL & MACHINING DETAIL

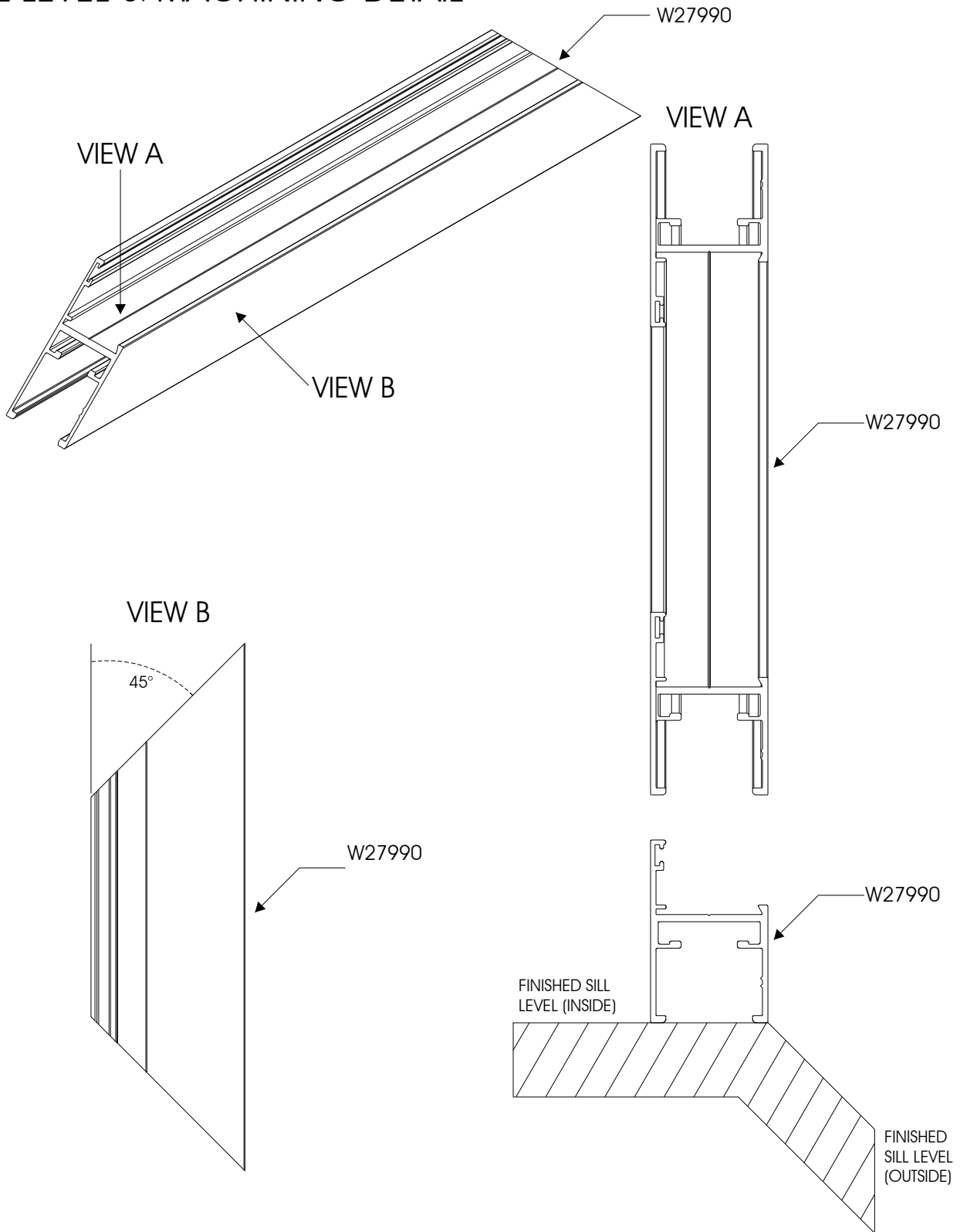

CASEMENT 30.5
WINDOW
UNEQUAL LEG OUTER FRAME
SILL LEVEL & MACHINING DETAIL

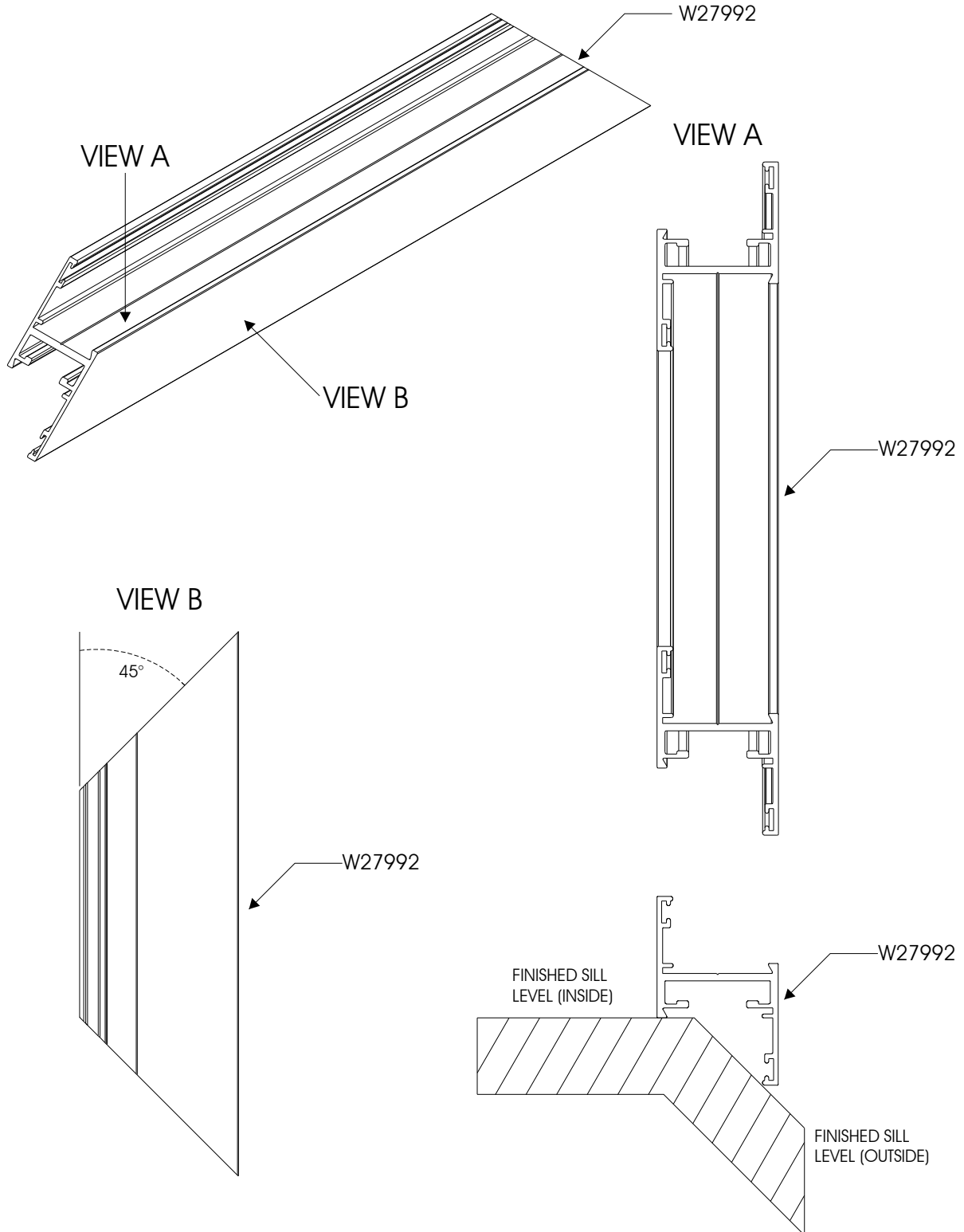

CASEMENT 30.5
 WINDOW
 54mm OUTER FRAME
 SILL LEVEL & MACHINING DETAIL

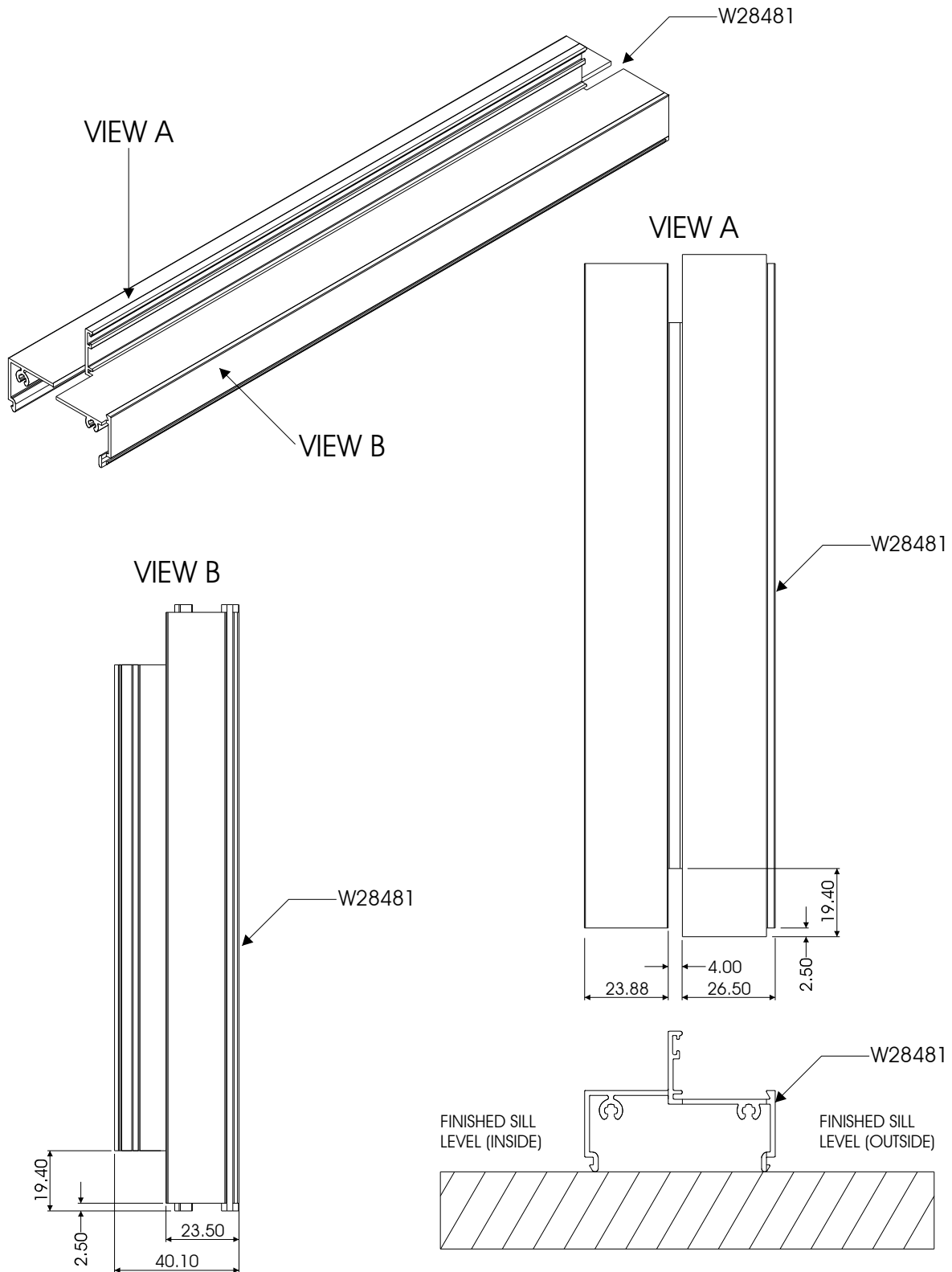

CASEMENT 30.5
 WINDOW
 70mm OUTER FRAME
 SILL LEVEL & MACHINING DETAIL

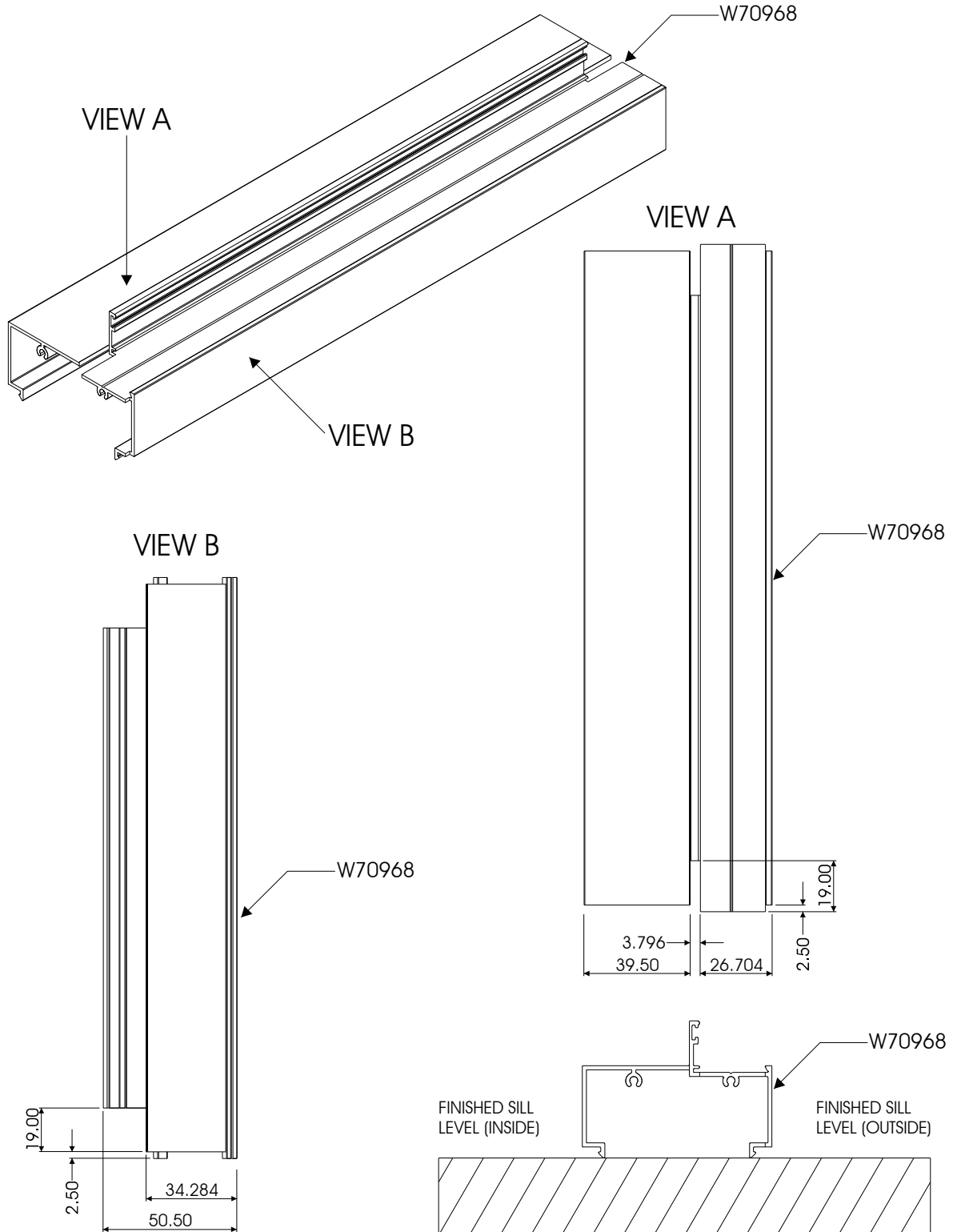

CASEMENT 30.5
WINDOW
LITE EQUAL LEG OUTER FRAME
SILL LEVEL & MACHINING DETAIL

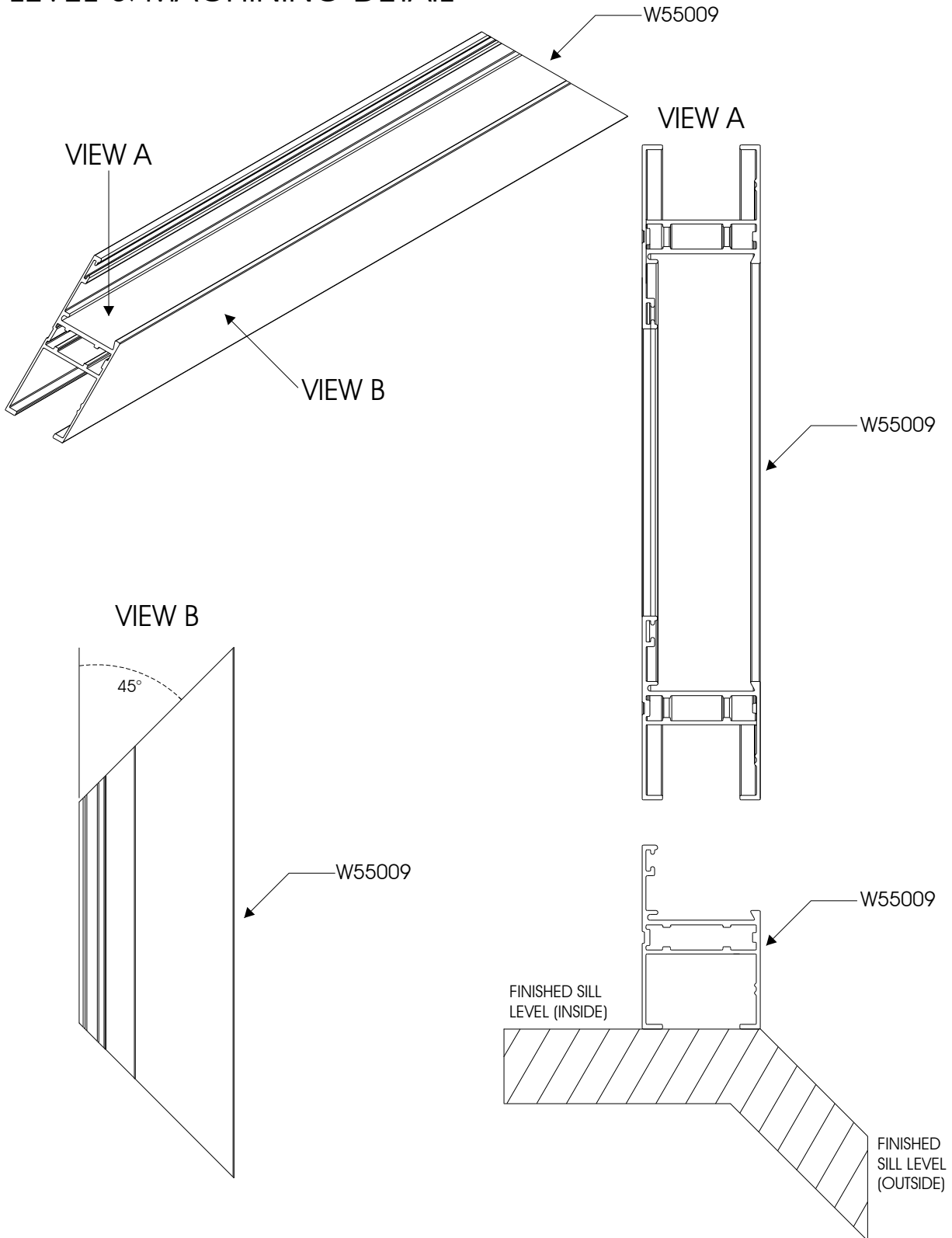

CASEMENT 30.5
 WINDOW
 STANDARD MULLION MACHINING
 DETAIL FOR END MILLING
 ON EQUAL LEG OUTER FRAME

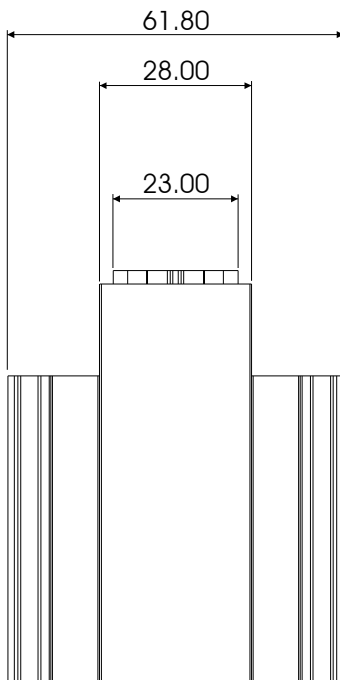
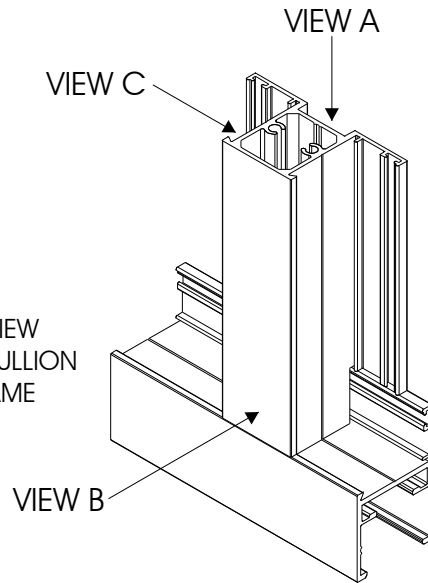
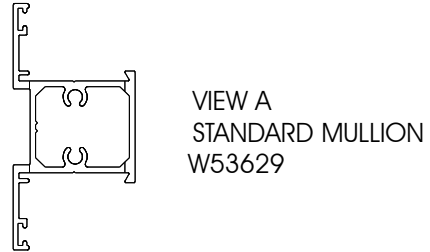
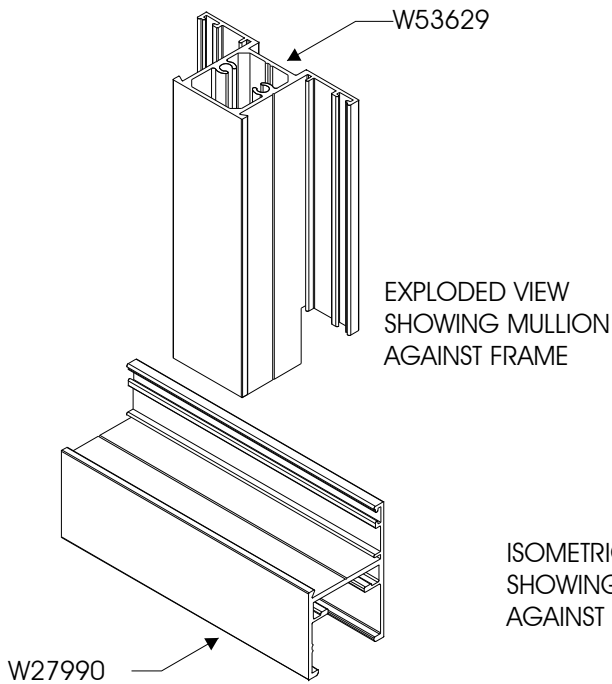

VIEW B

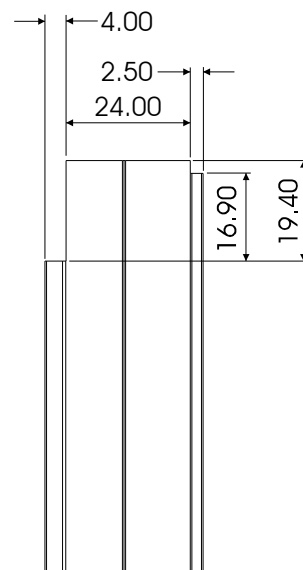

VIEW C

CASEMENT 30.5
 WINDOW
 STANDARD MULLION MACHINING
 DETAIL FOR END MILLING
 ON UNEQUAL LEG OUTER FRAME

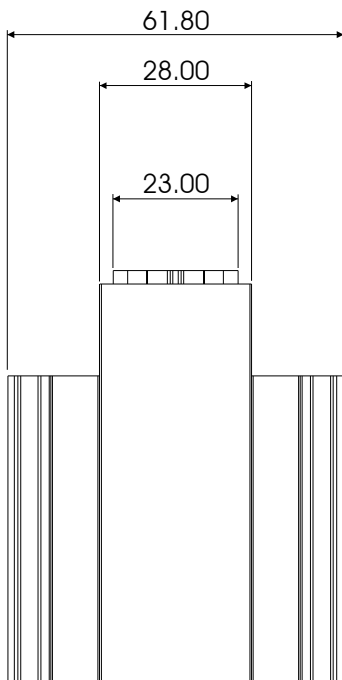
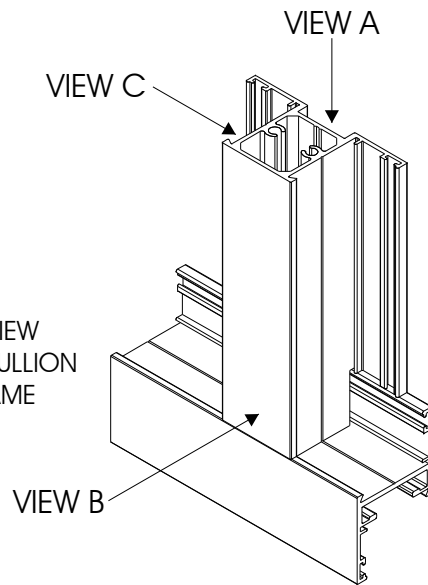
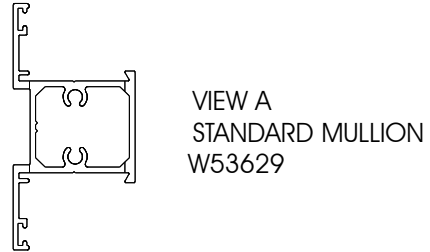
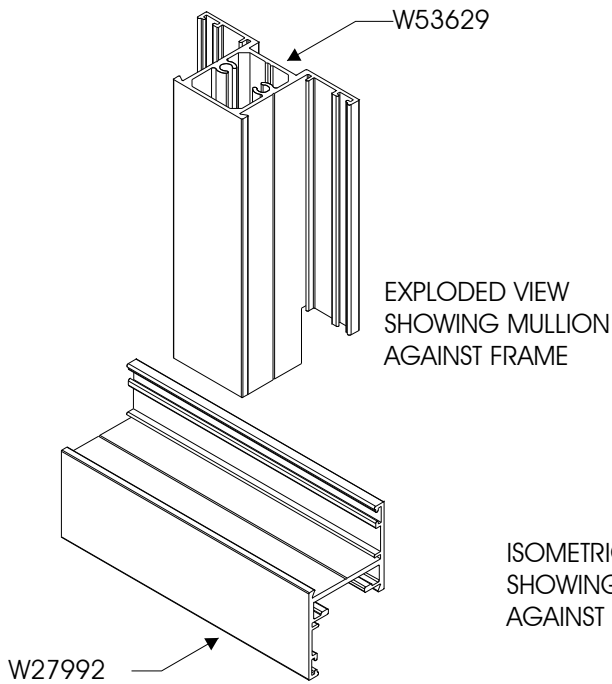

VIEW B

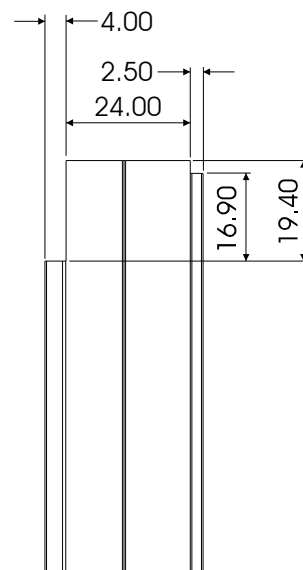

VIEW C

CASEMENT 30.5
 WINDOW
 STANDARD MULLION MACHINING
 DETAIL FOR END MILLING
 ON 54mm OUTER FRAME

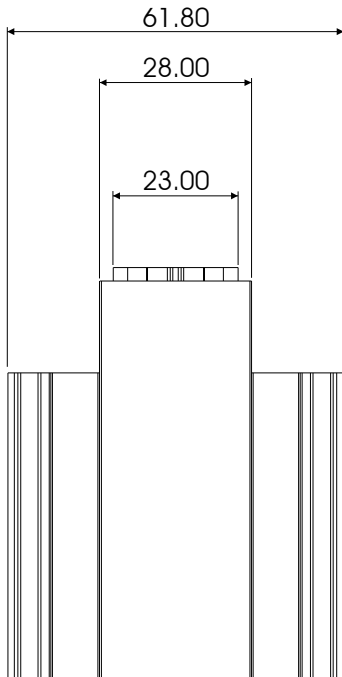
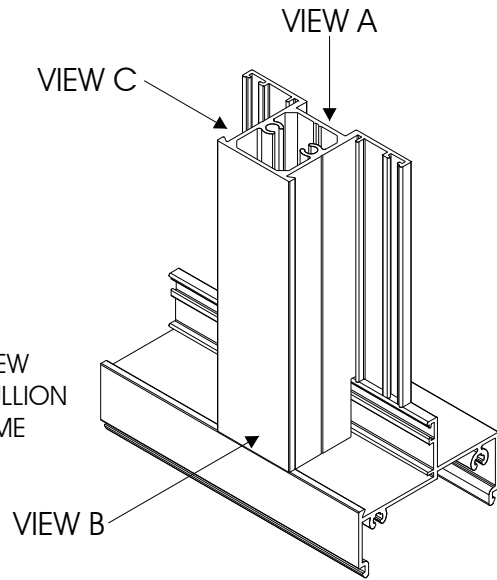
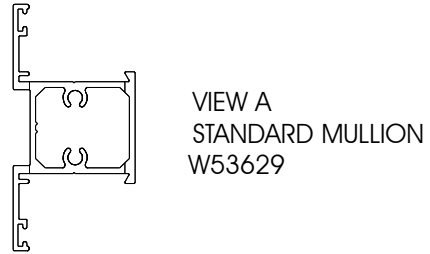
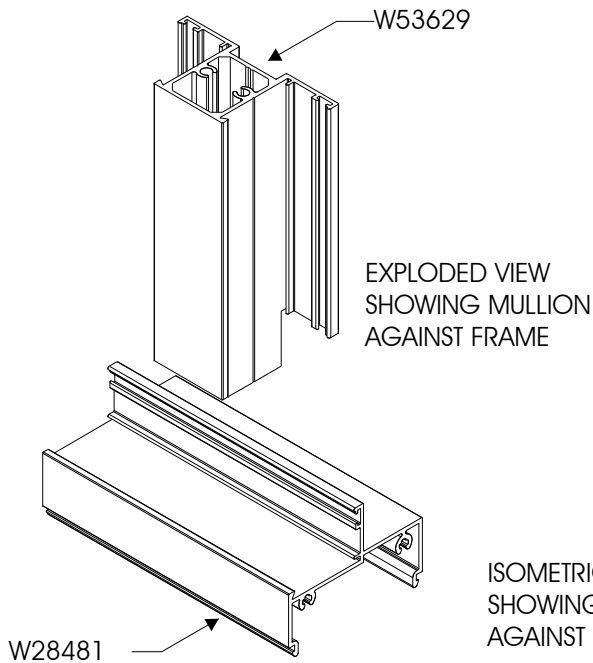

VIEW B

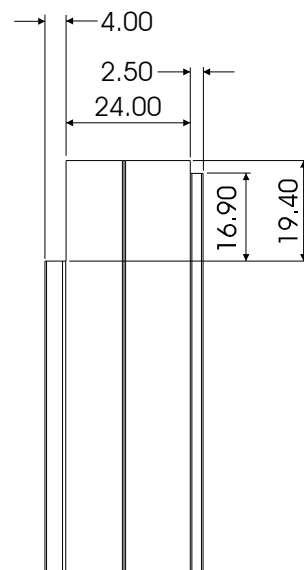

VIEW C

CASEMENT 30.5
 WINDOW
 STANDARD MULLION MACHINING
 DETAIL FOR END MILLING
 ON 70mm OUTER FRAME

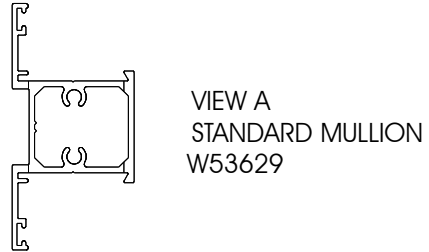
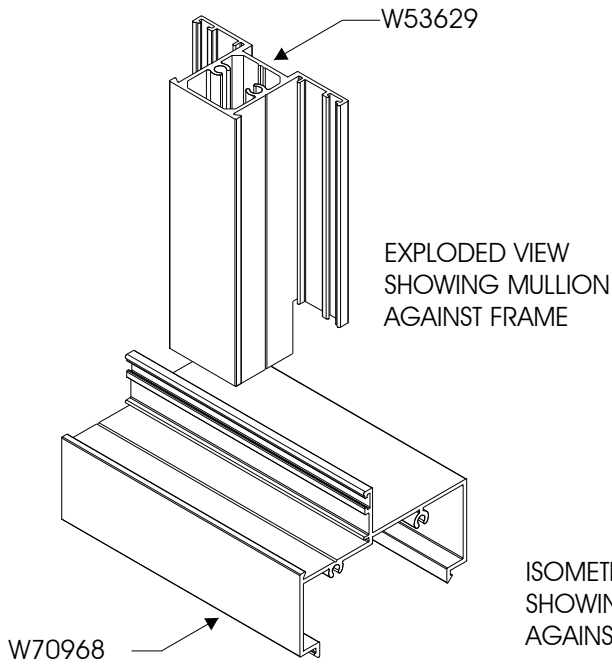

ISOMETRIC VIEW
 SHOWING MULLION
 AGAINST FRAME

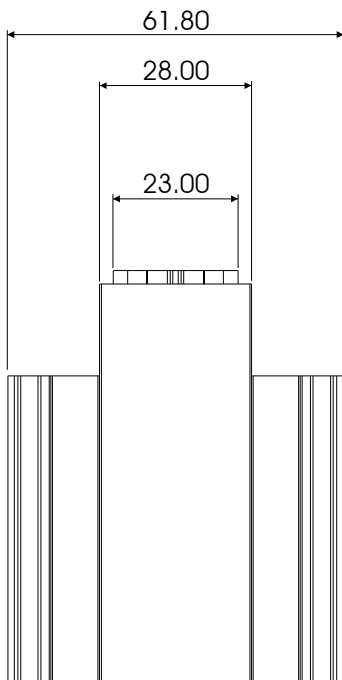
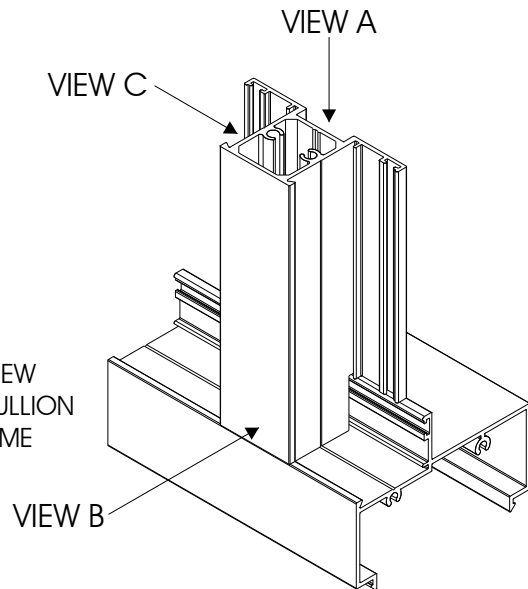

VIEW B

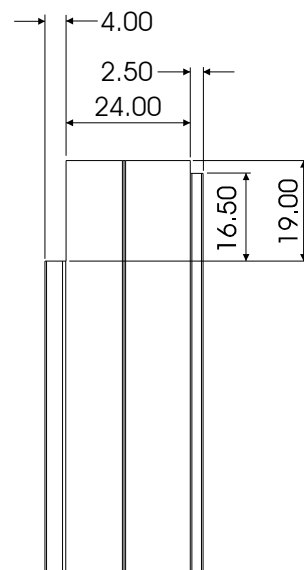

VIEW C

CASEMENT 30.5
 WINDOW
 STANDARD MULLION MACHINING
 DETAIL FOR END MILLING
 ON LITE EQUAL LEG OUTER FRAME

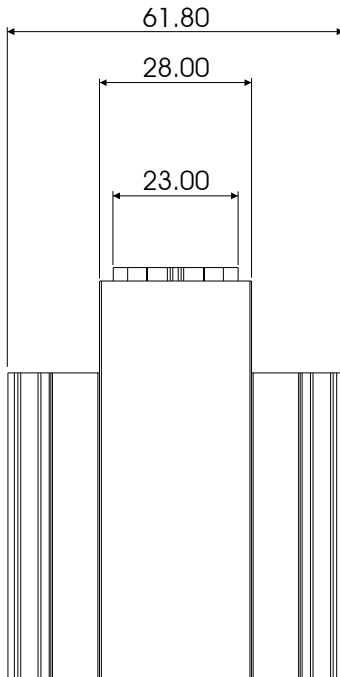
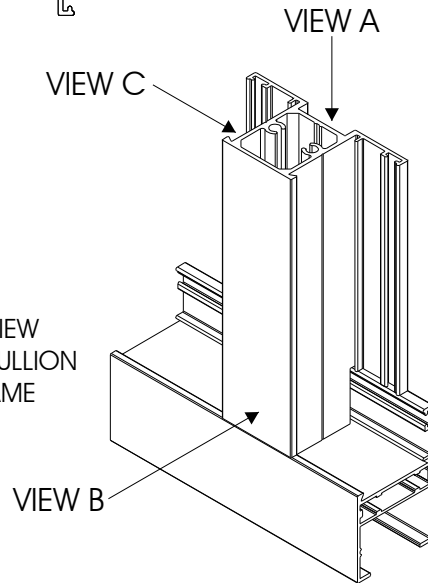
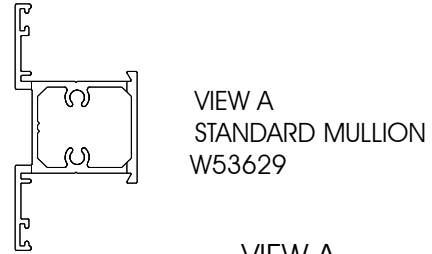
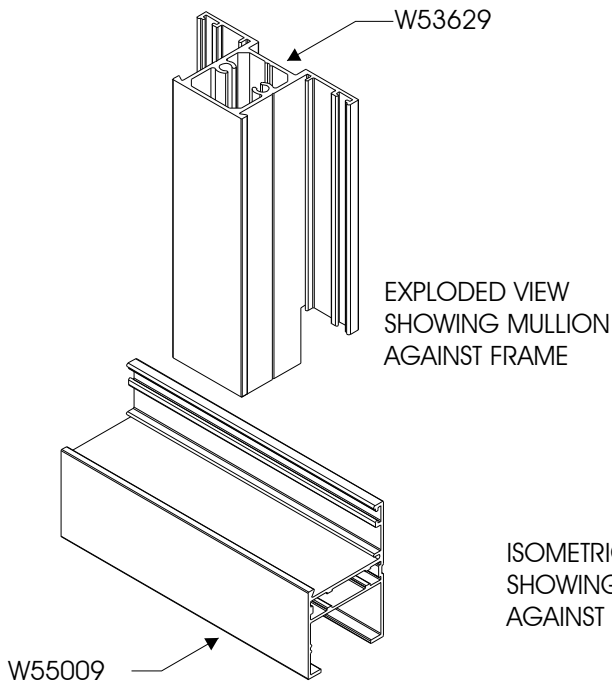

VIEW B

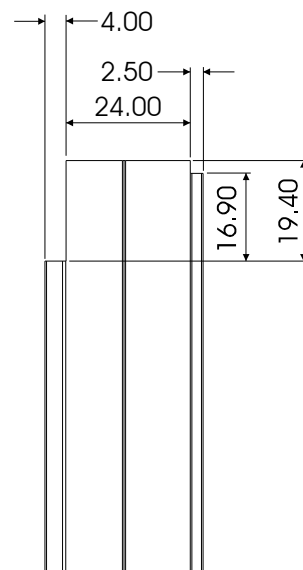

VIEW C

CASEMENT 30.5
 WINDOW
 STANDARD TRANSOM WITH W/B
 MACHINING DETAIL FOR END MILLING
 ON EQUAL LEG OUTER FRAME

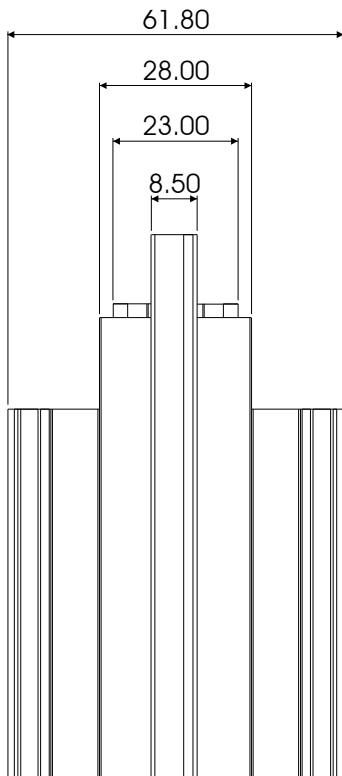
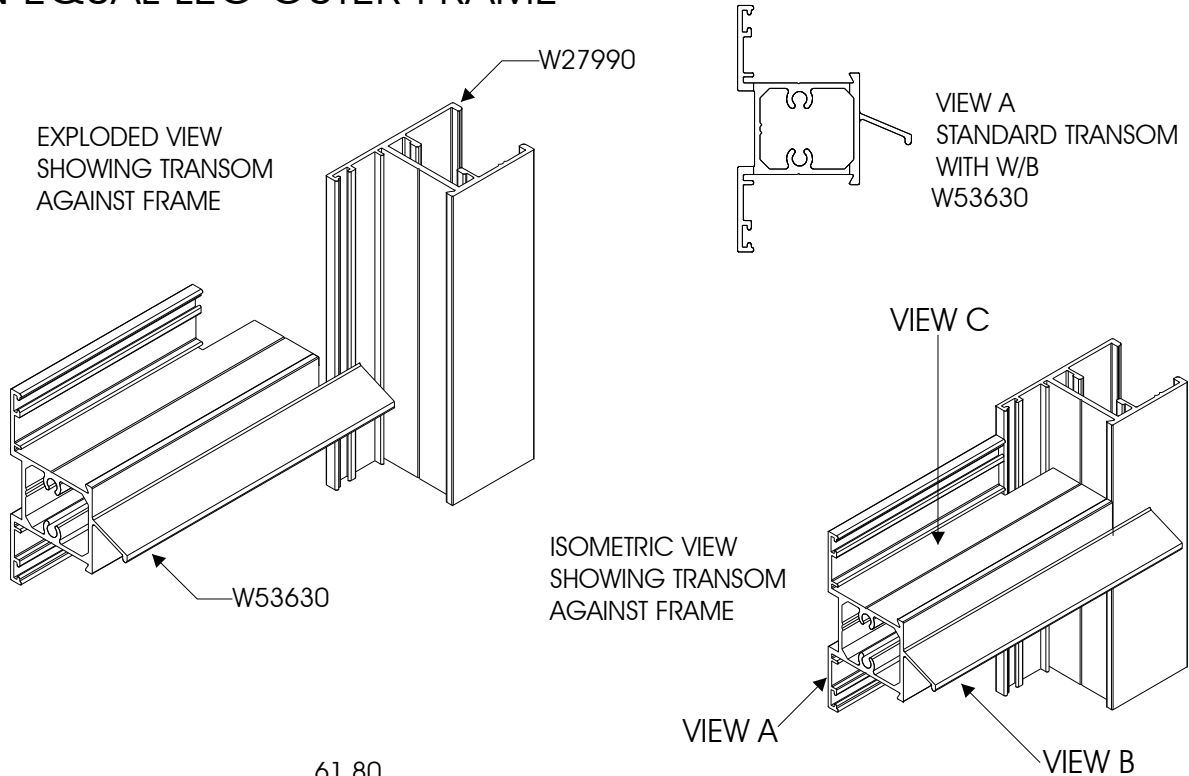

VIEW B

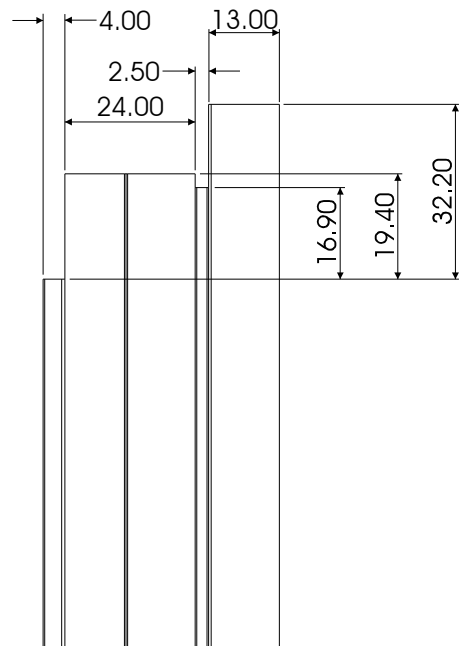

VIEW C

CASEMENT 30.5
 WINDOW
 STANDARD TRANSOM WITH W/B
 MACHINING DETAIL FOR END MILLING
 ON UNEQUAL LEG OUTER FRAME

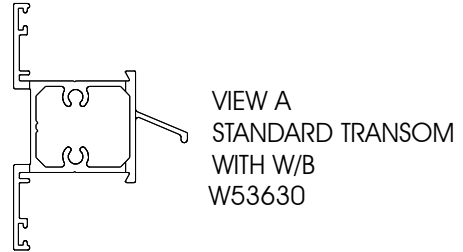
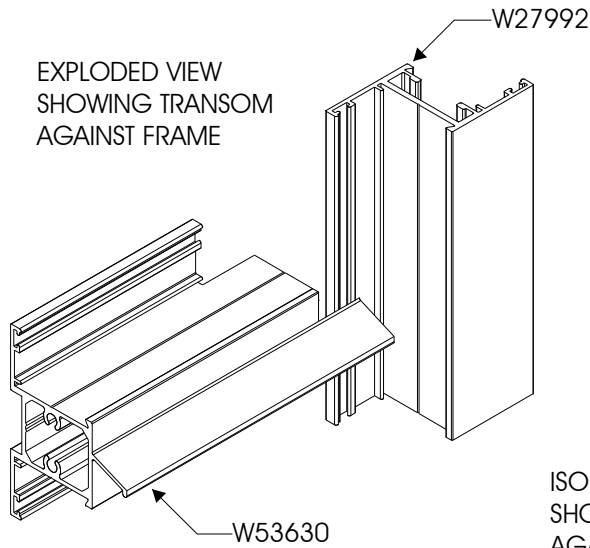

ISOMETRIC VIEW
 SHOWING TRANSOM
 AGAINST FRAME

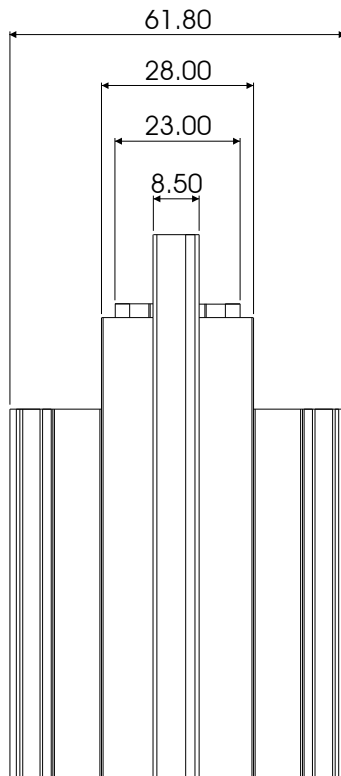
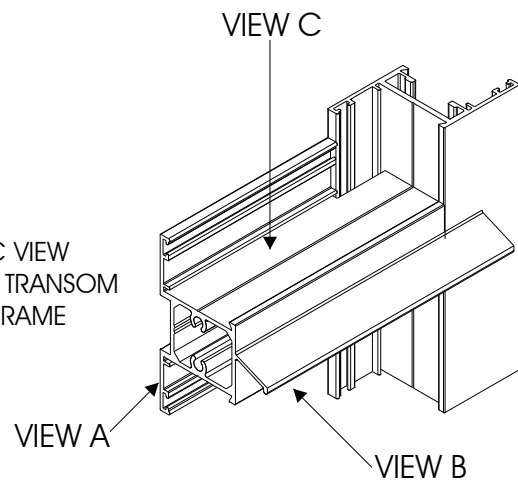

VIEW B

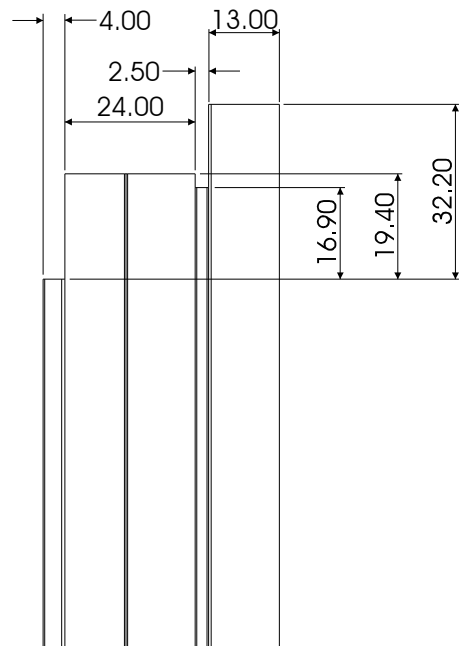

VIEW C

CASEMENT 30.5
 WINDOW
 STANDARD TRANSOM WITH W/B
 MACHINING DETAIL FOR END MILLING
 ON 54mm OUTER FRAME

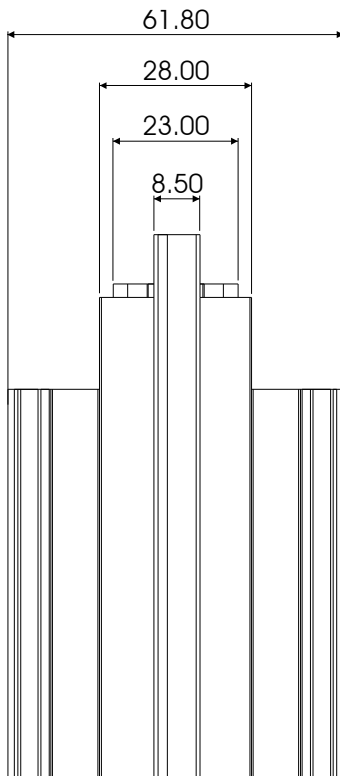
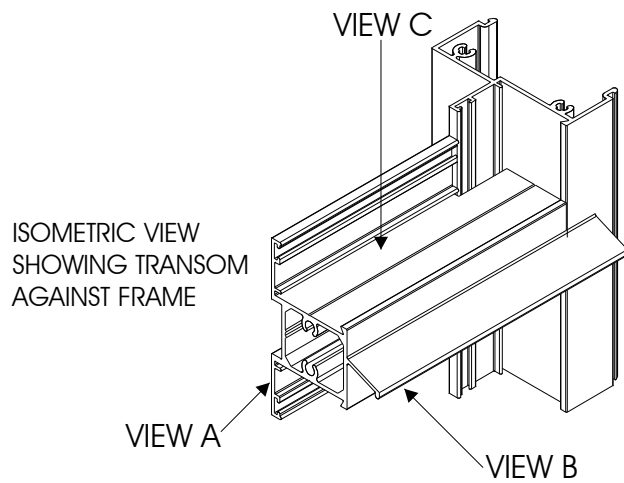
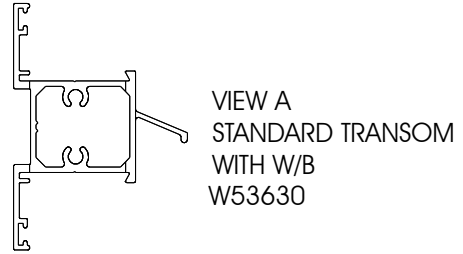
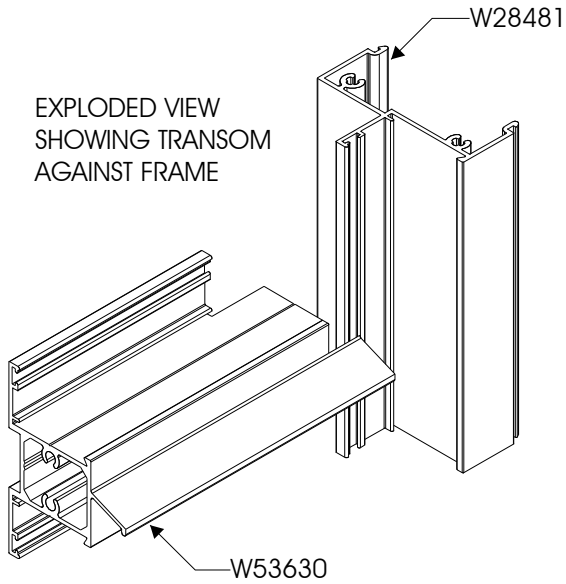

VIEW B

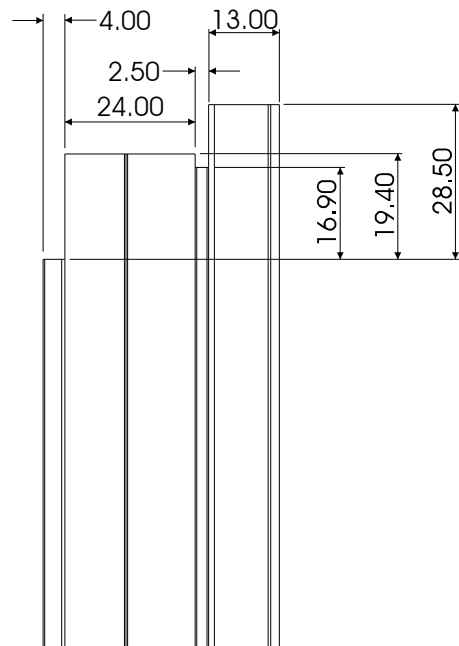

VIEW C

CASEMENT 30.5
 WINDOW
 STANDARD TRANSOM WITH W/B
 MACHINING DETAIL FOR END MILLING
 ON 70mm OUTER FRAME

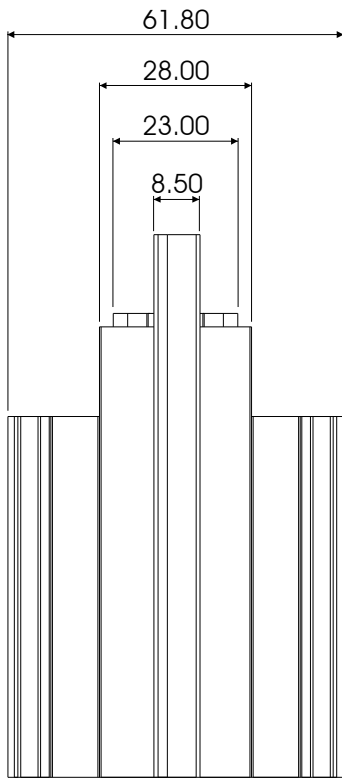
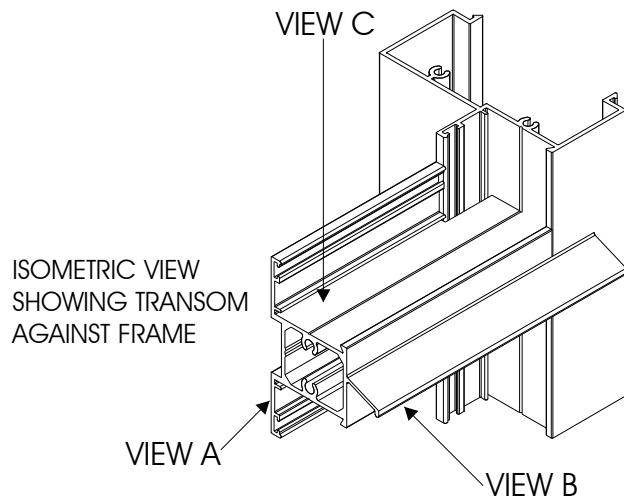
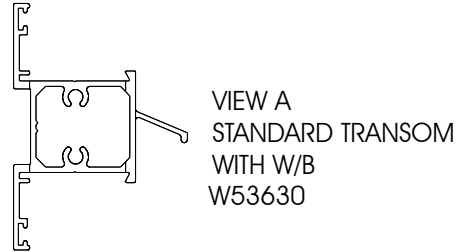
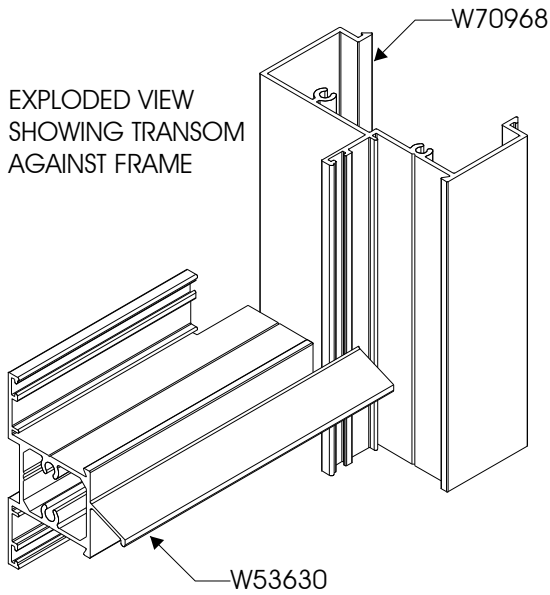

VIEW B

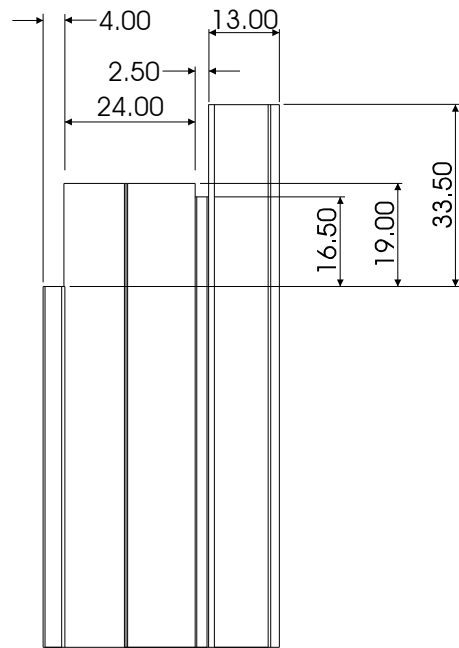

VIEW C

CASEMENT 30.5
 WINDOW
 STANDARD TRANSOM WITH W/B
 MACHINING DETAIL FOR END MILLING
 ON LITE EQUAL LEG OUTER FRAME

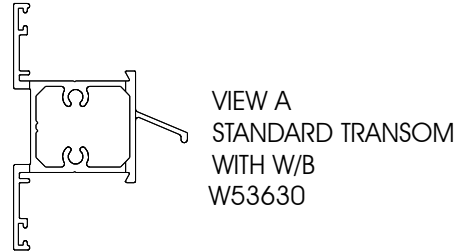
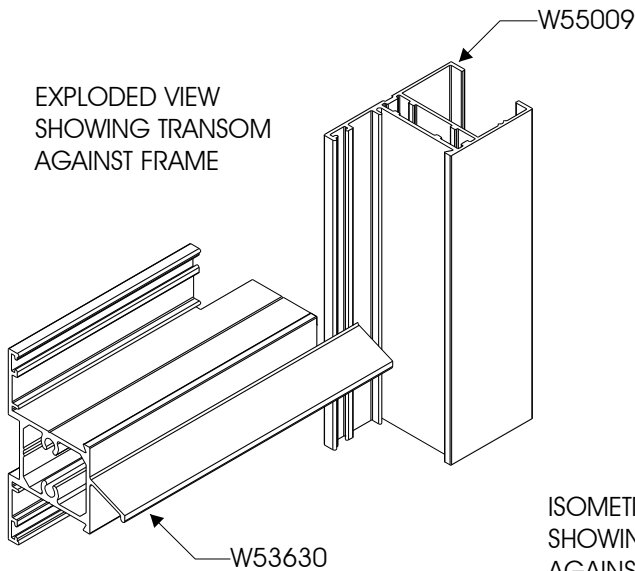

ISOMETRIC VIEW
 SHOWING TRANSOM
 AGAINST FRAME

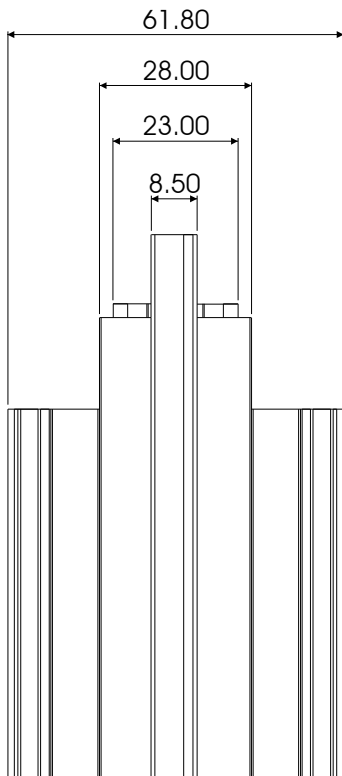
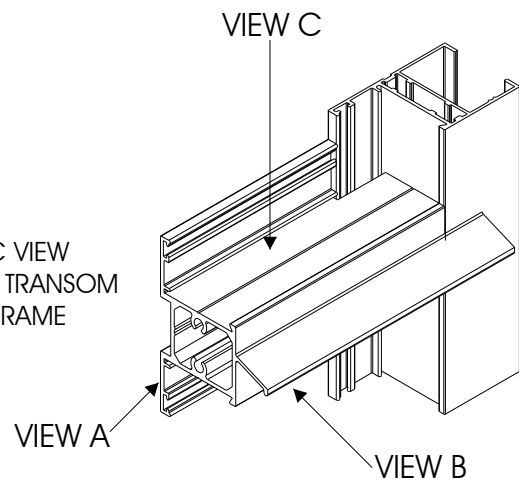

VIEW B

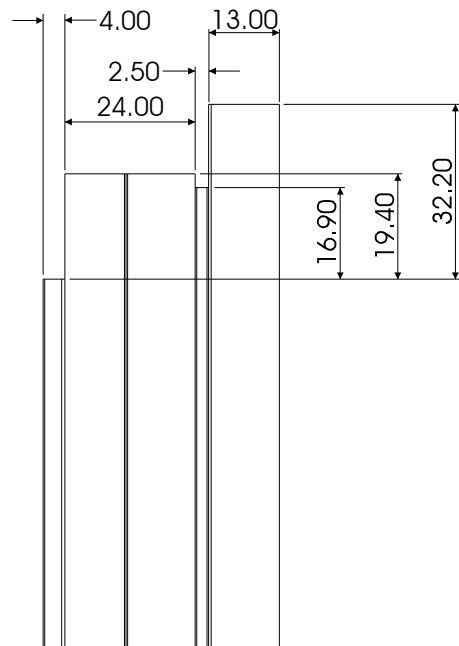

VIEW C



CASEMENT 30.5
 WINDOW
 54mm MULLION MACHINING
 DETAIL FOR END MILLING
 ON EQUAL LEG OUTER FRAME

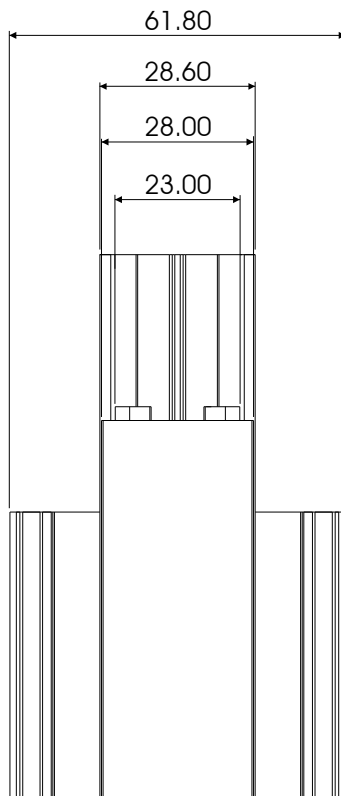
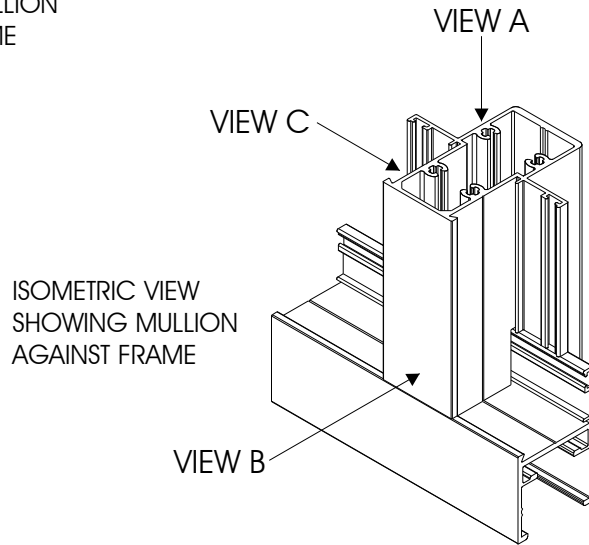
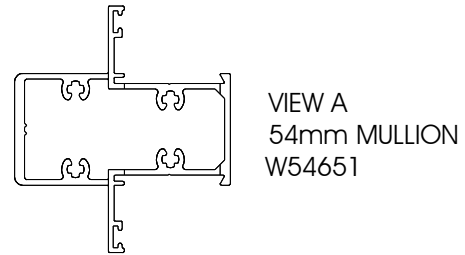
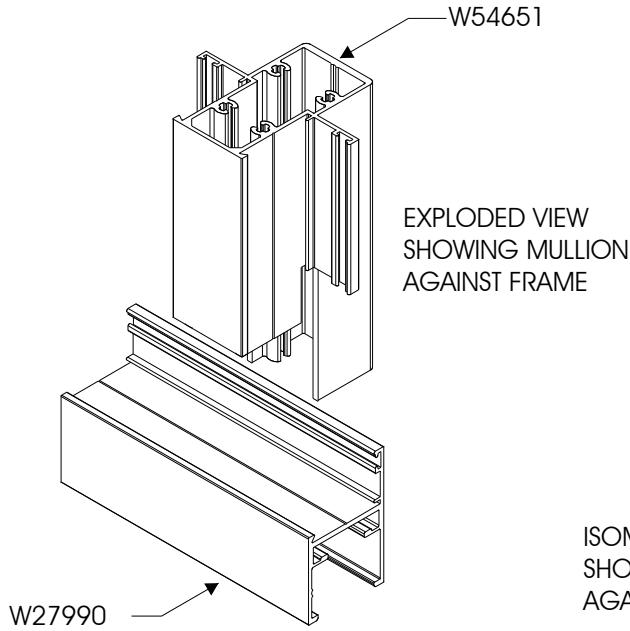

VIEW B

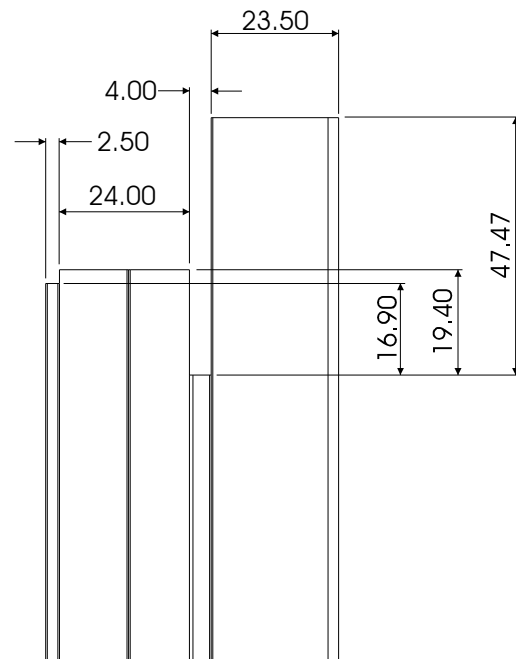

VIEW C

CASEMENT 30.5
 WINDOW
 54mm MULLION MACHINING
 DETAIL FOR END MILLING
 ON UNEQUAL LEG OUTER FRAME

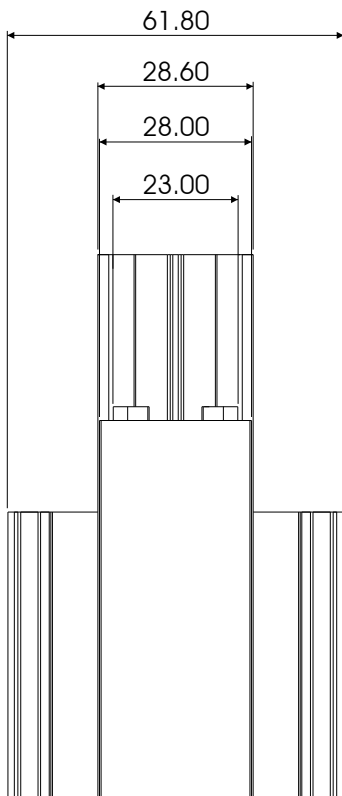
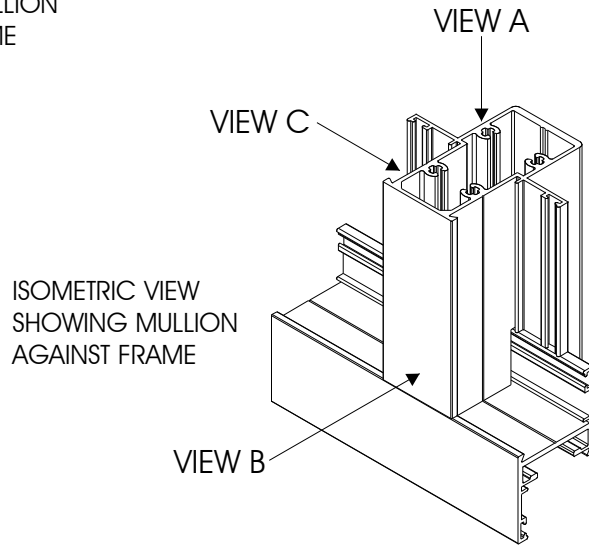
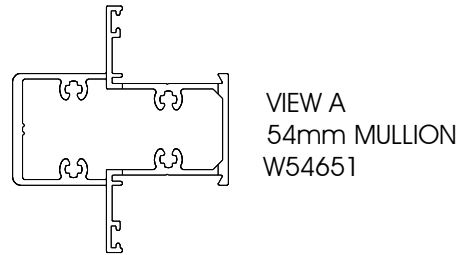
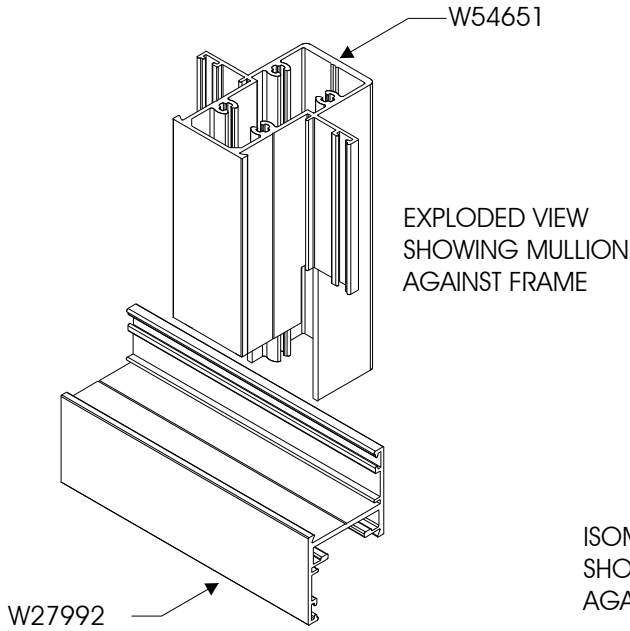

VIEW B

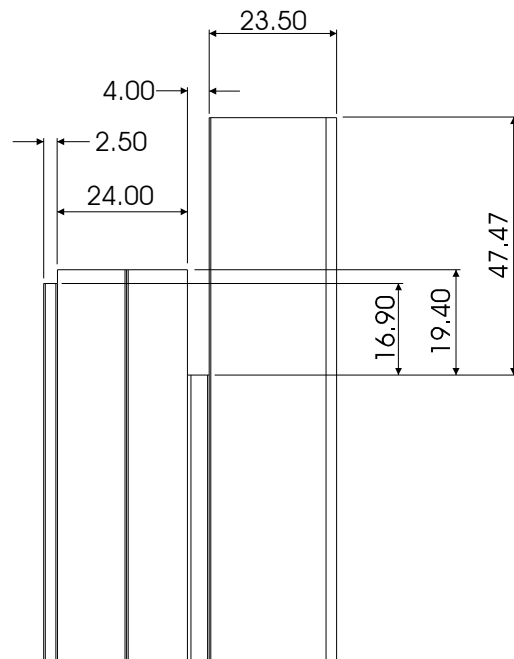

VIEW C

CASEMENT 30.5
 WINDOW
 54mm MULLION MACHINING
 DETAIL FOR END MILLING
 ON 54mm OUTER FRAME

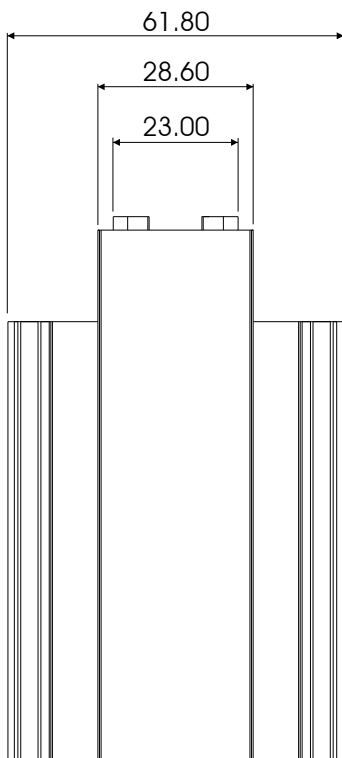
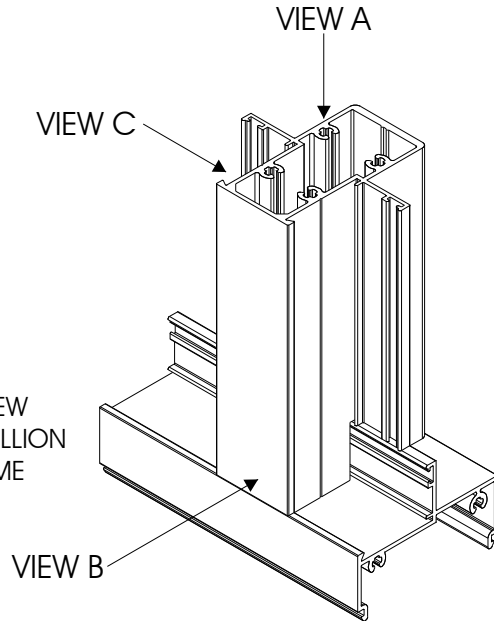
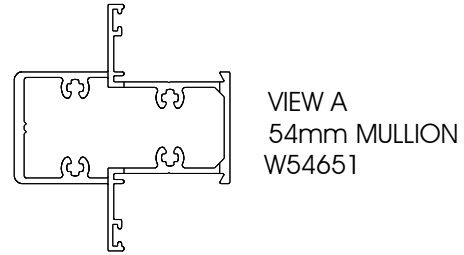
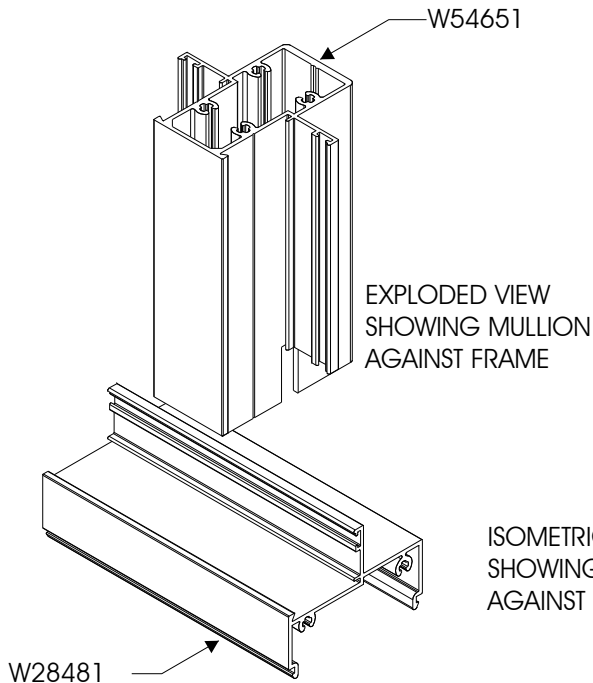

VIEW B

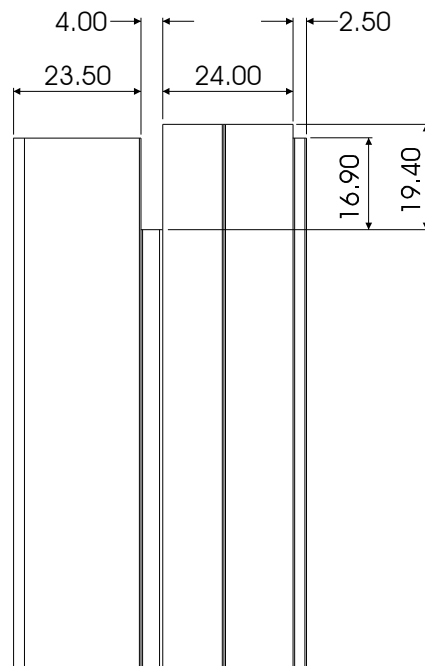

VIEW C

CASEMENT 30.5
 WINDOW
 54mm MULLION MACHINING
 DETAIL FOR END MILLING
 ON 70mm OUTER FRAME

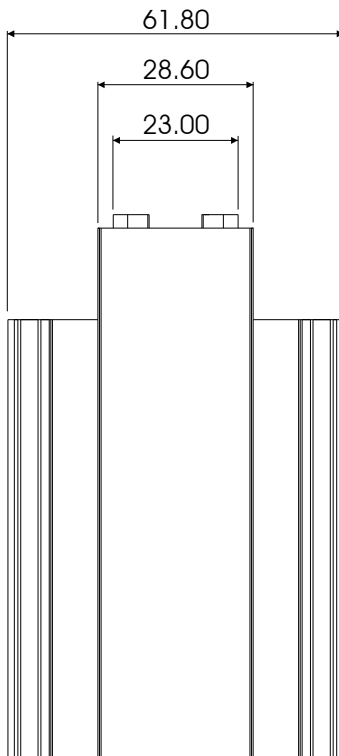
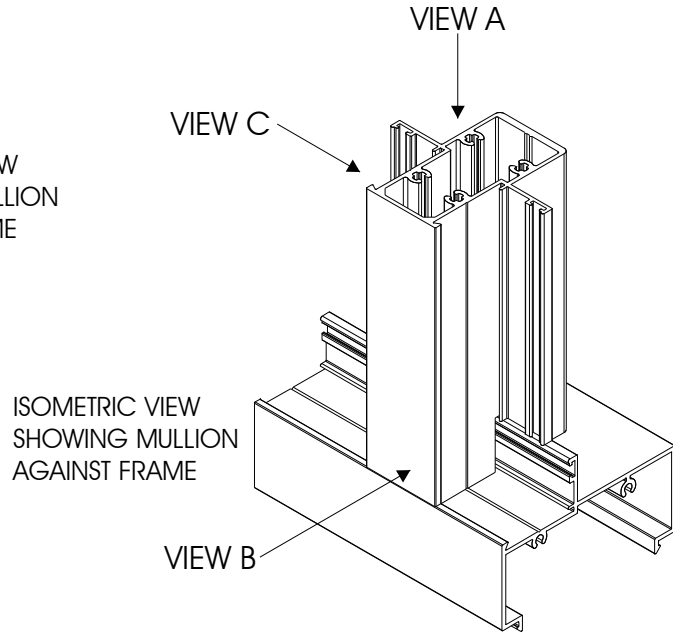
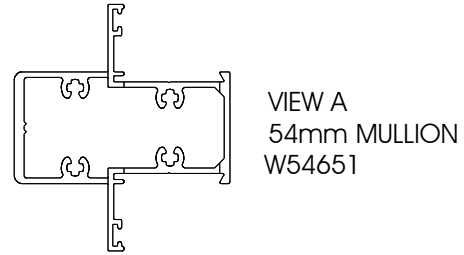
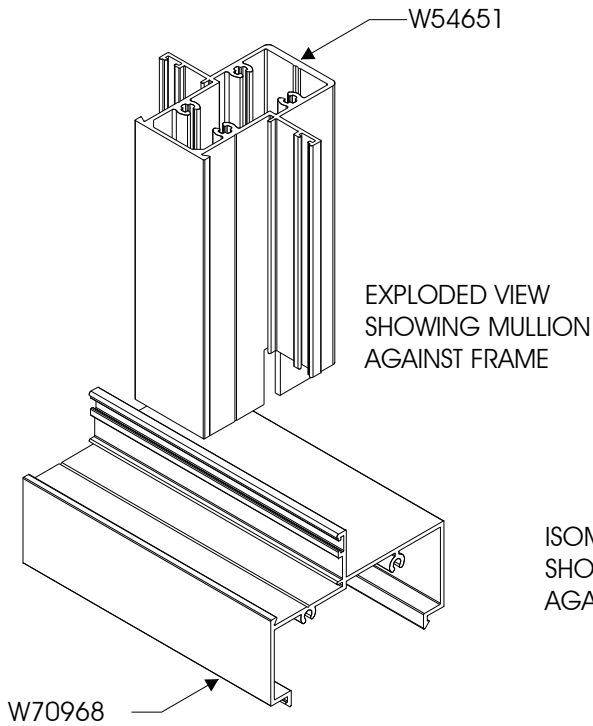

VIEW B

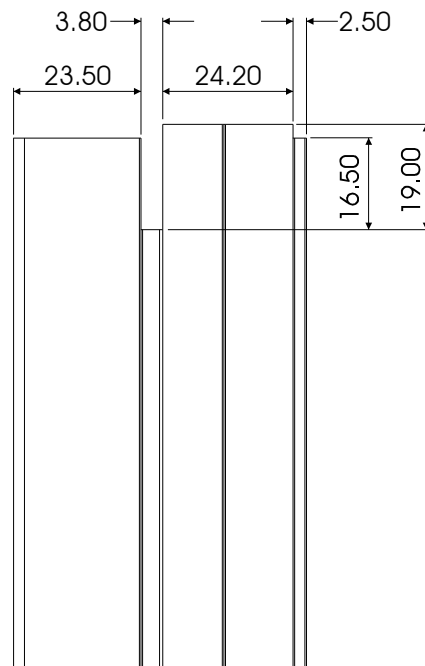

VIEW C

CASEMENT 30.5
 WINDOW
 54mm MULLION MACHINING
 DETAIL FOR END MILLING
 ON LITE EQUAL LEG OUTER FRAME

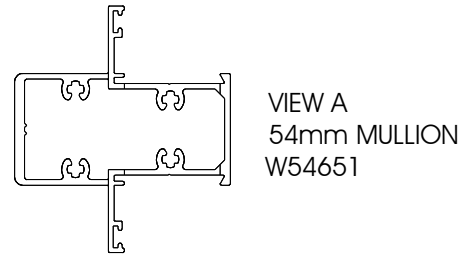
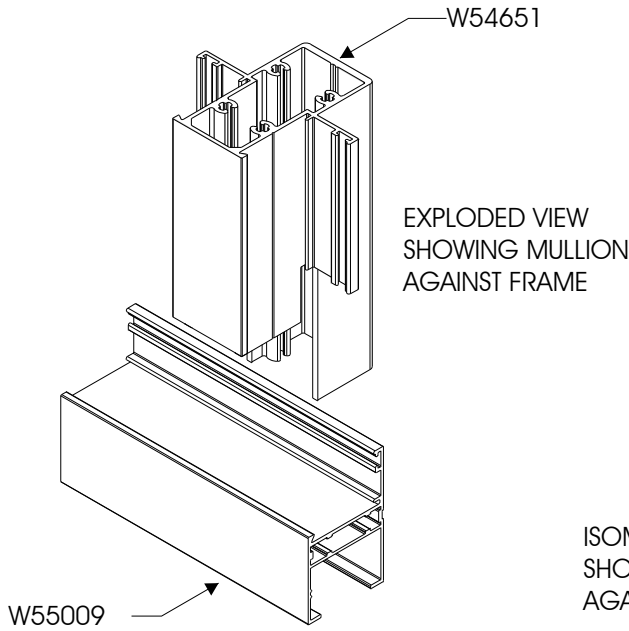

ISOMETRIC VIEW
 SHOWING MULLION
 AGAINST FRAME

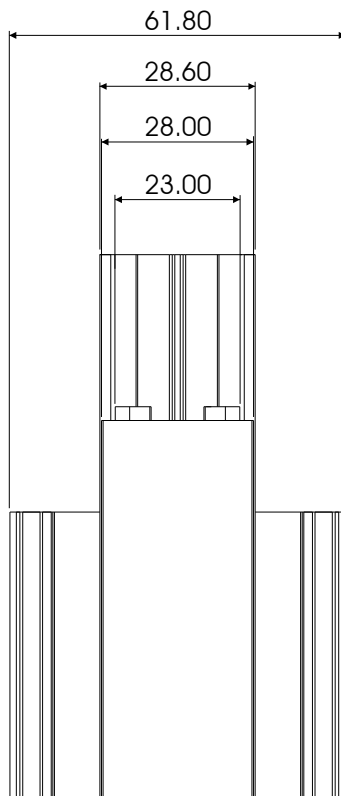
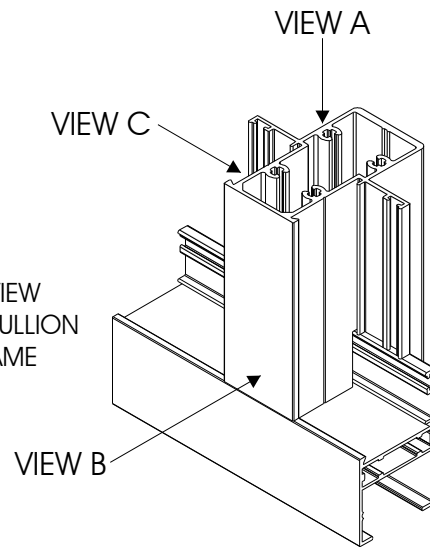

VIEW B

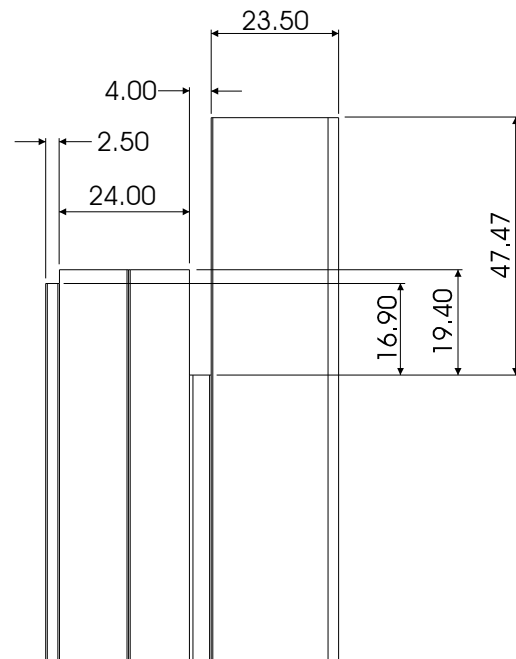

VIEW C

CASEMENT 30.5
 WINDOW
 70mm MULLION MACHINING
 DETAIL FOR END MILLING
 ON EQUAL LEG OUTER FRAME

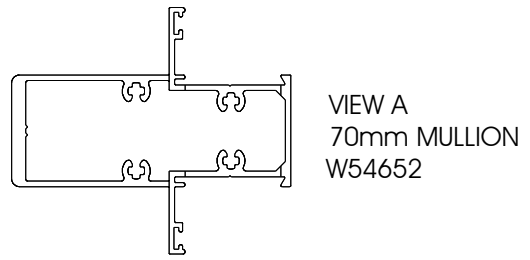
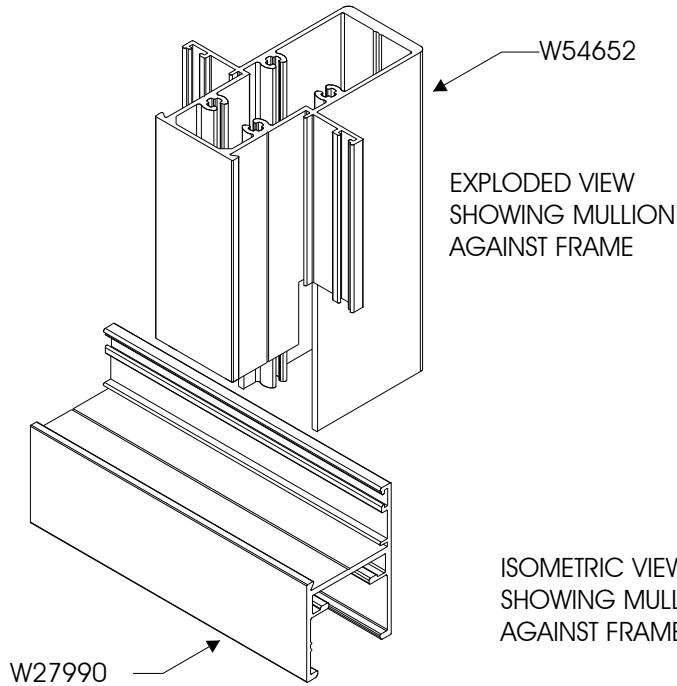

ISOMETRIC VIEW
 SHOWING MULLION
 AGAINST FRAME

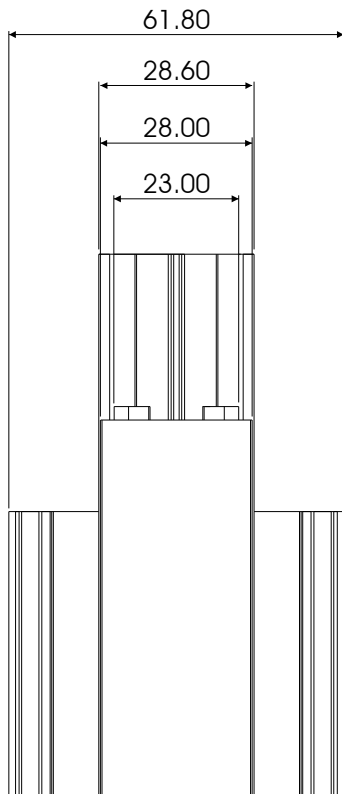
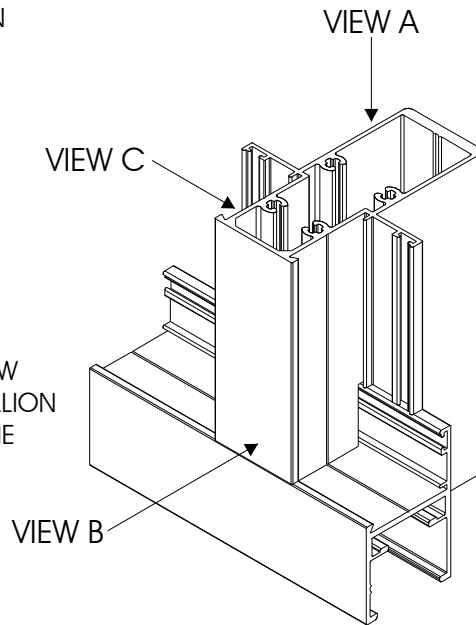

VIEW B

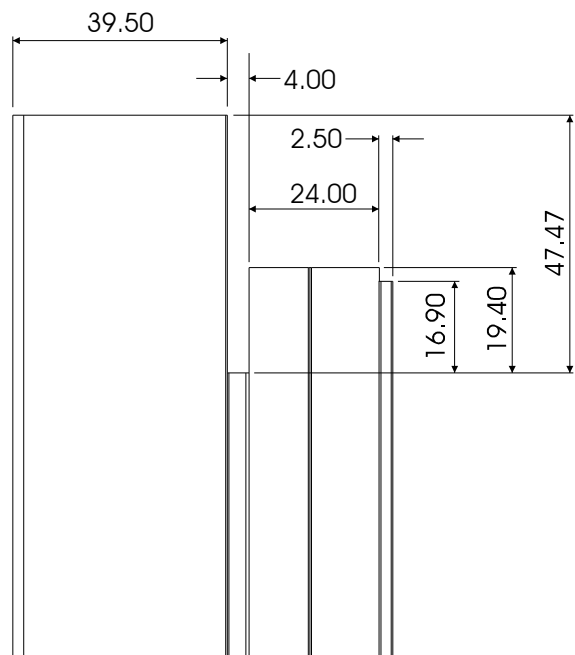

VIEW C

CASEMENT 30.5
 WINDOW
 70mm MULLION MACHINING
 DETAIL FOR END MILLING
 ON UNEQUAL LEG OUTER FRAME

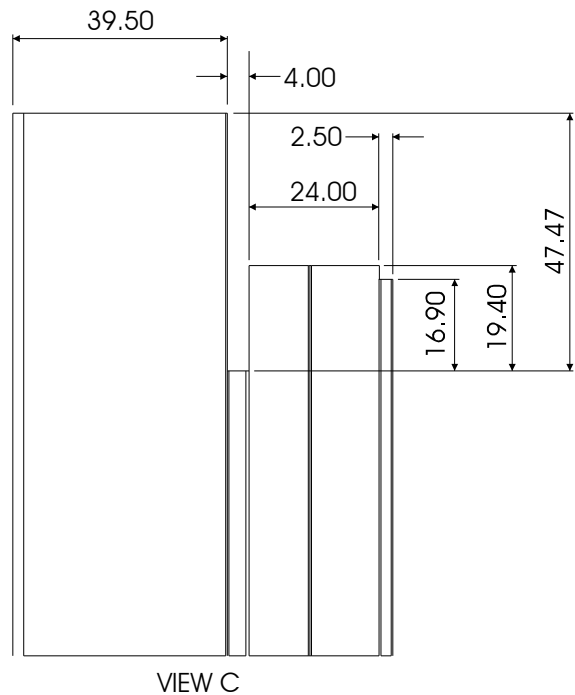
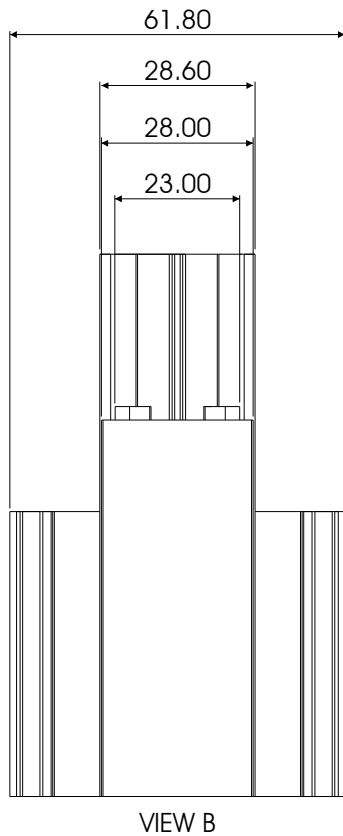
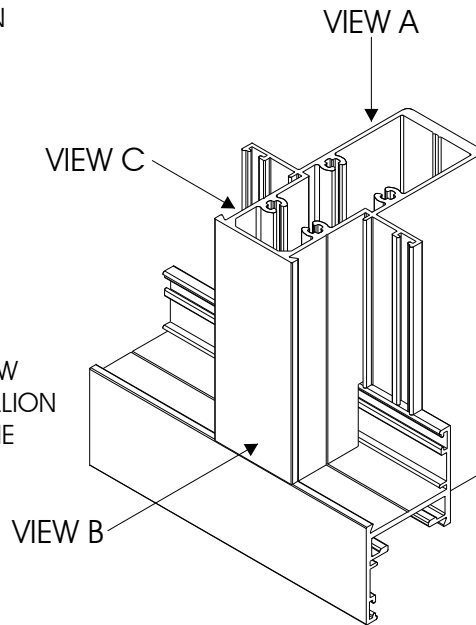
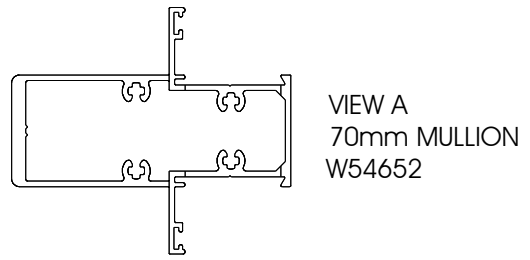
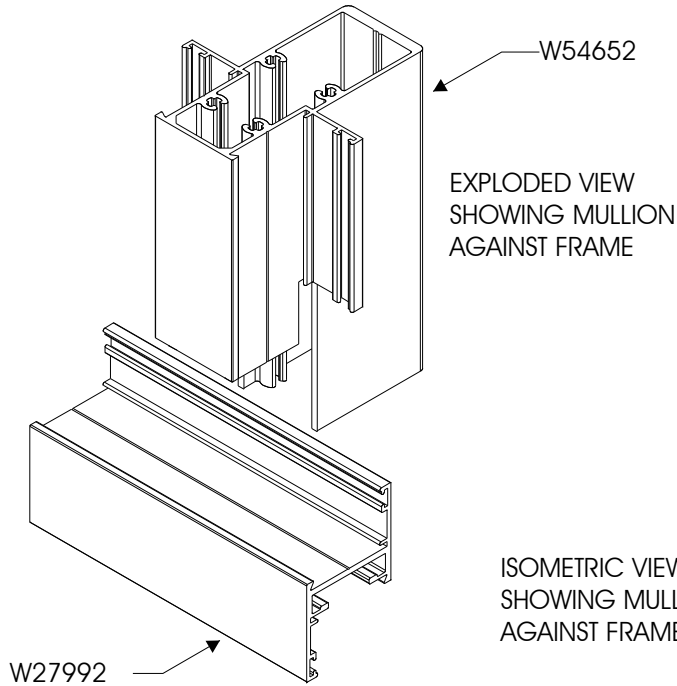

CASEMENT 30.5

WINDOW

70mm MULLION MACHINING

DETAIL FOR END MILLING ON 54mm OUTER FRAME

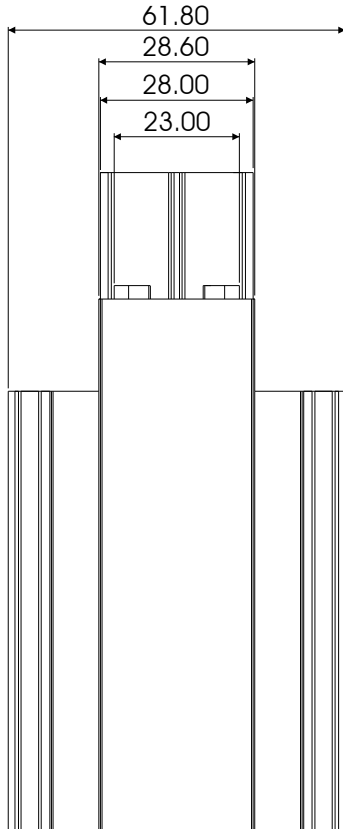
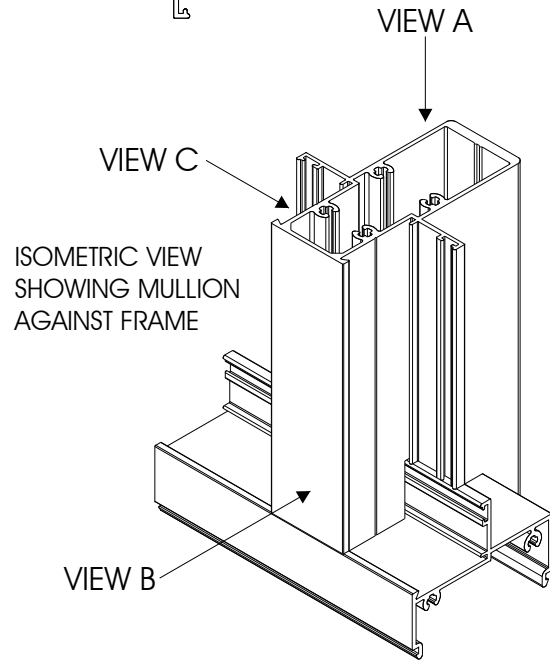
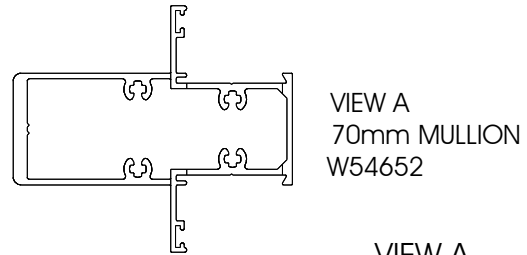
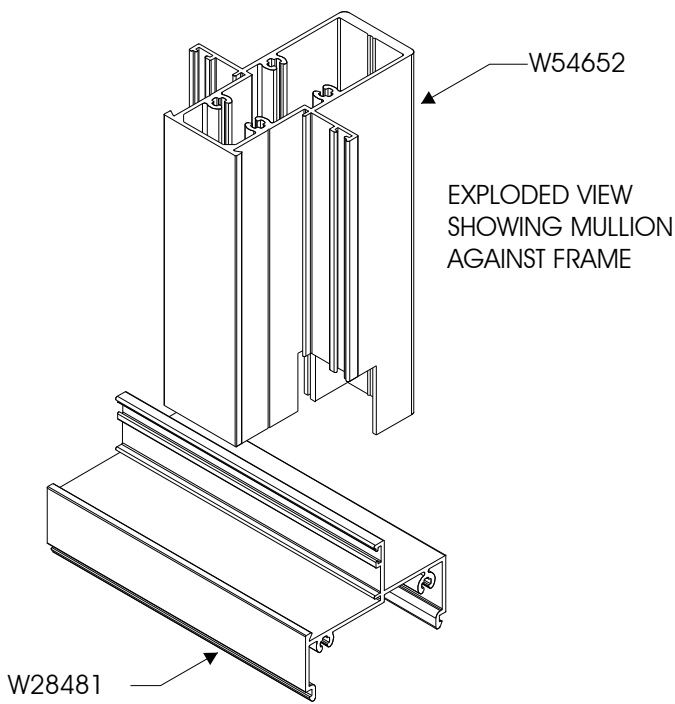

VIEW B

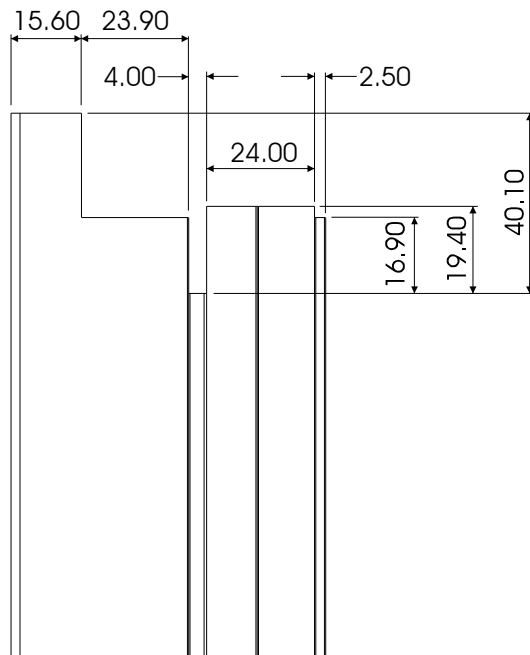

VIEW C

CASEMENT 30.5
 WINDOW
 70mm MULLION MACHINING
 DETAIL FOR END MILLING
 ON 70mm OUTER FRAME

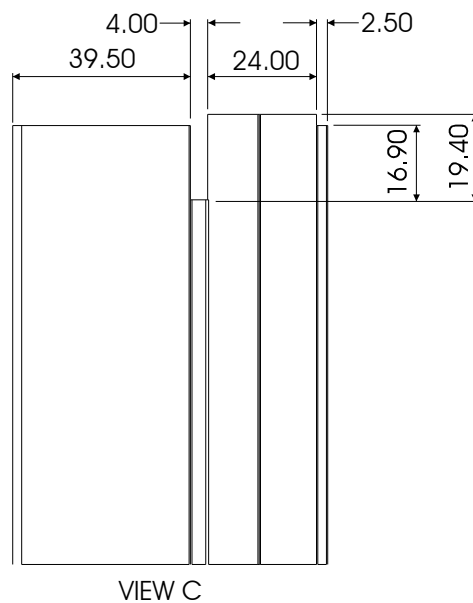
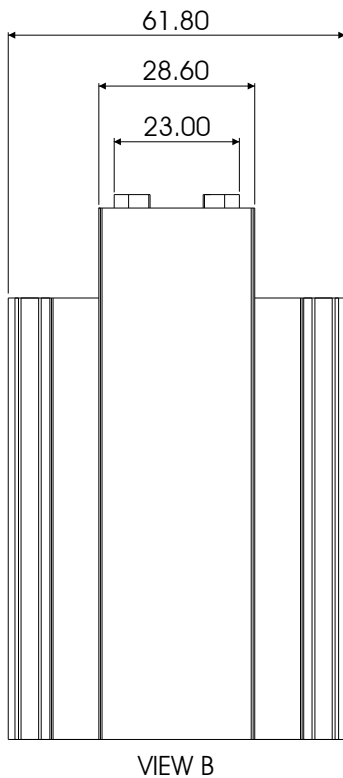
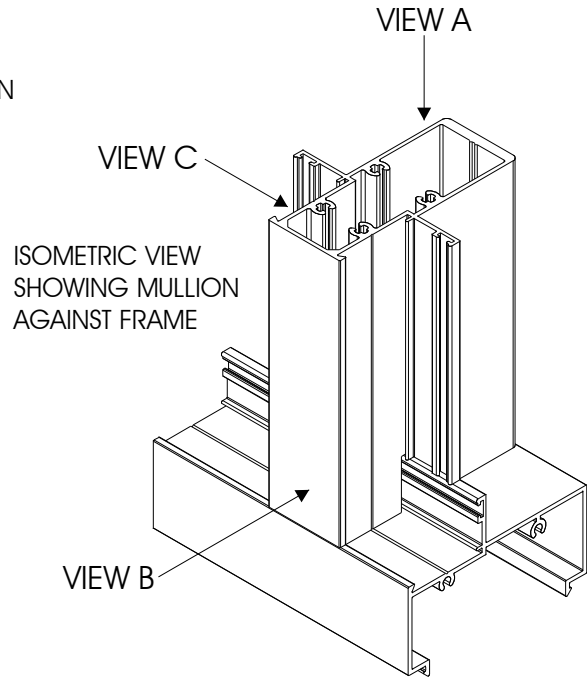
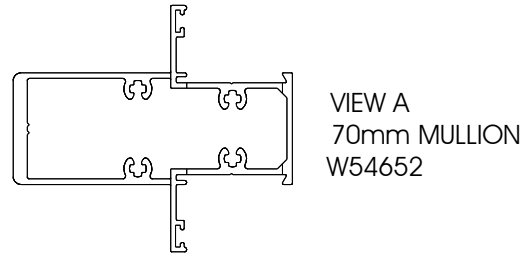
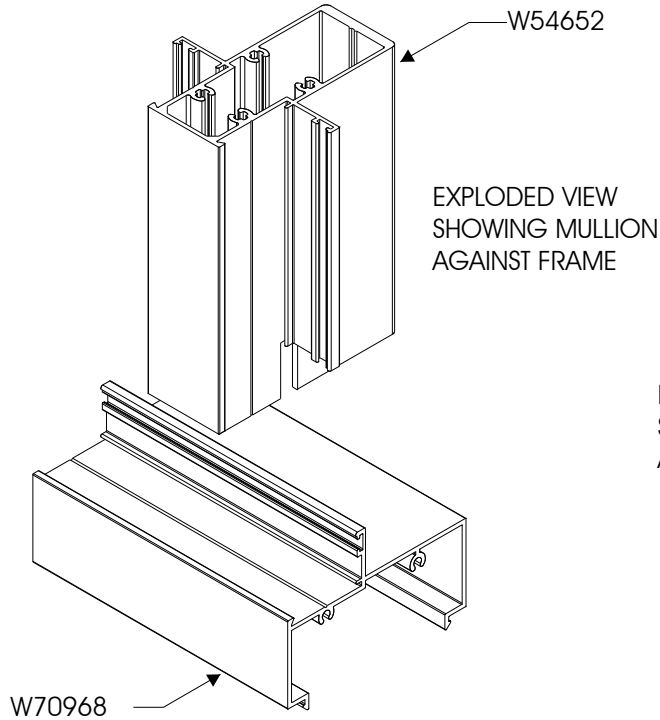

CASEMENT 30.5
 WINDOW
 70mm MULLION MACHINING
 DETAIL FOR END MILLING
 ON LITE EQUAL LEG OUTER FRAME

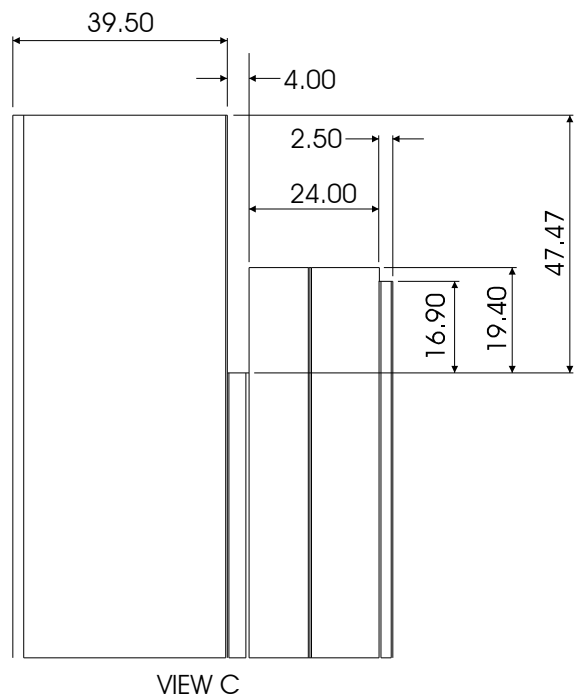
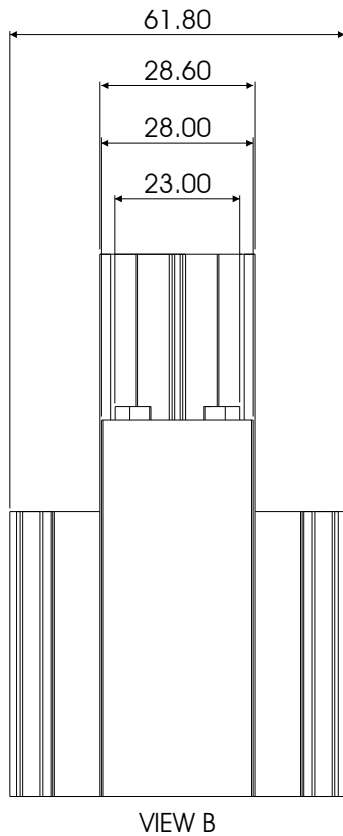
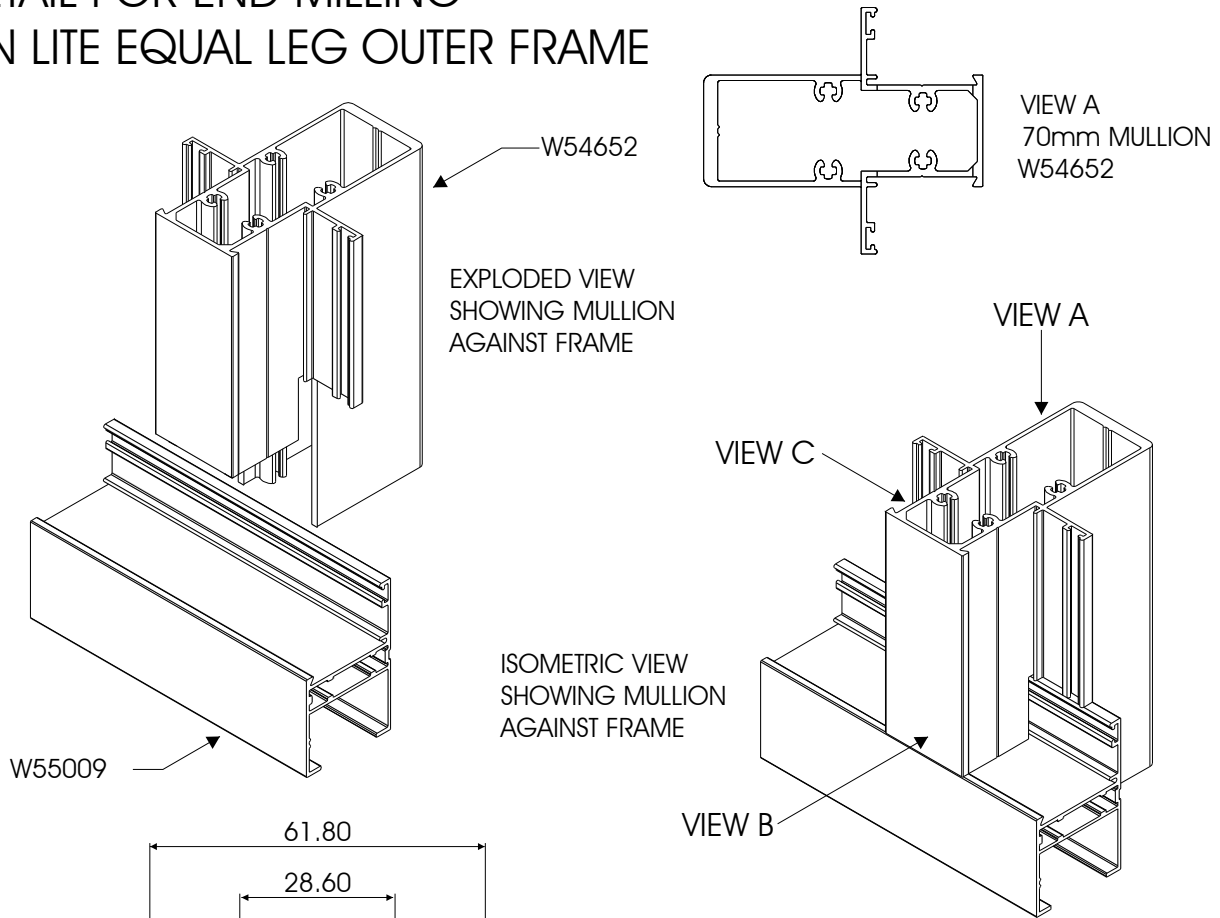

CASEMENT 30.5
 WINDOW
 COTTAGE PANE MULLION
 MACHINING DETAIL FOR END MILLING
 ON EQUAL LEG OUTER FRAME

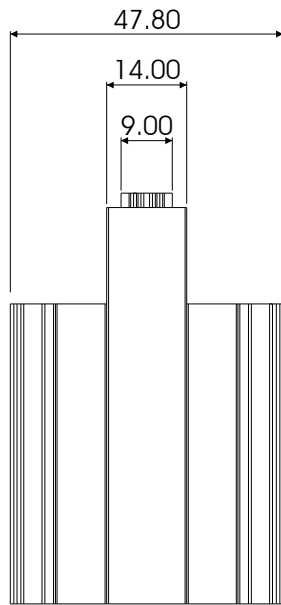
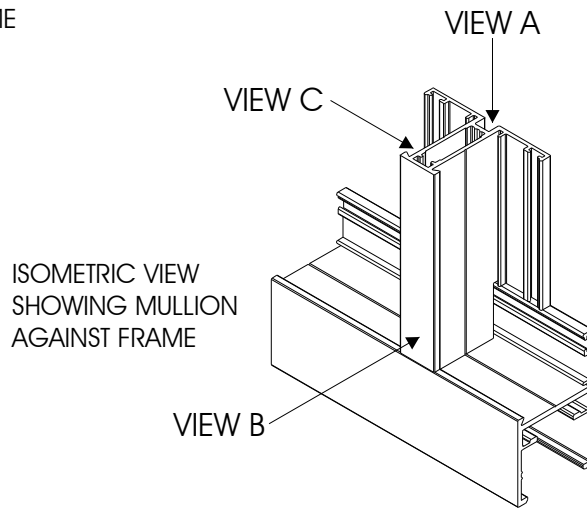
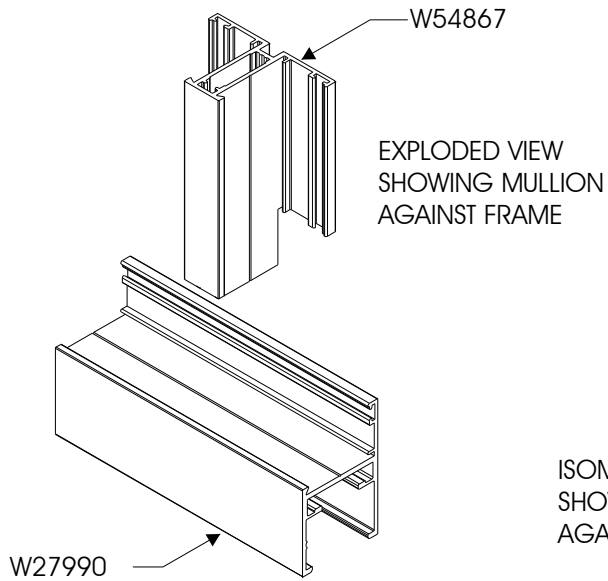

VIEW B

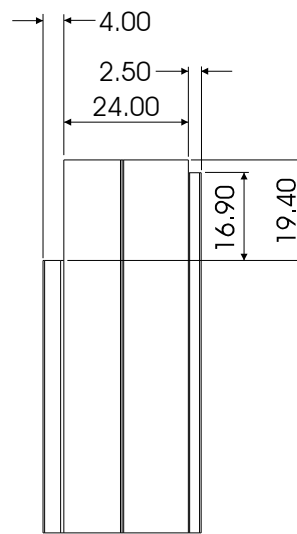

VIEW C

CASEMENT 30.5
 WINDOW
 COTTAGE PANE MULLION
 MACHINING DETAIL FOR END MILLING
 ON UNEQUAL LEG OUTER FRAME

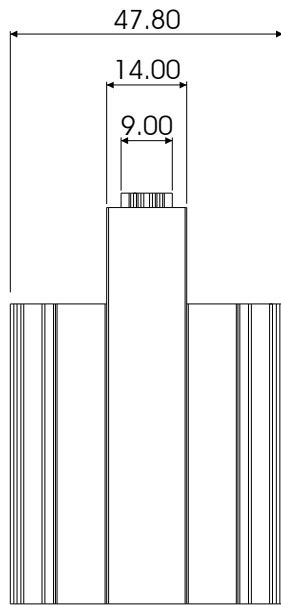
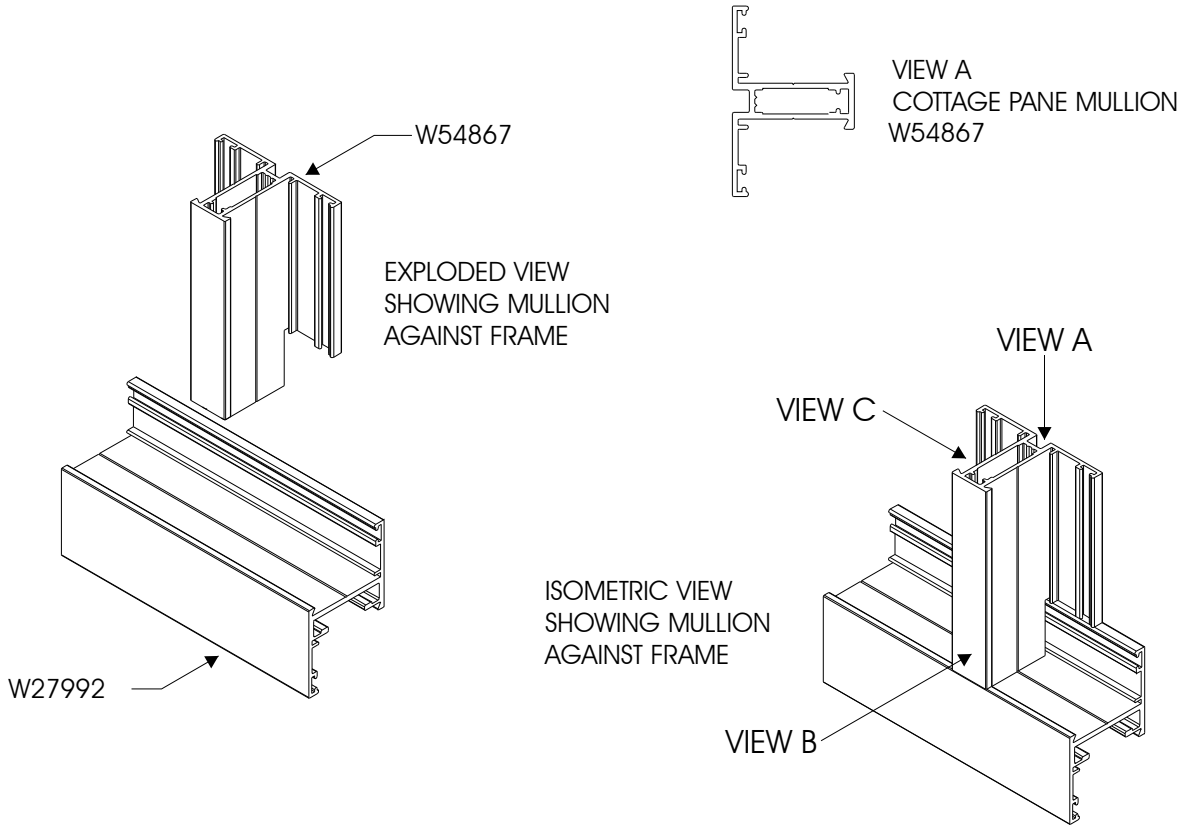

VIEW B

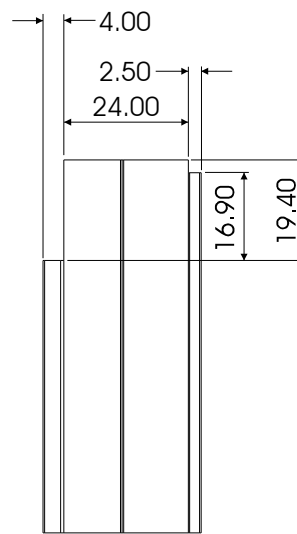

VIEW C

CASEMENT 30.5
 WINDOW
 COTTAGE PANE MULLION
 MACHINING DETAIL FOR END MILLING
 ON 54mm OUTER FRAME

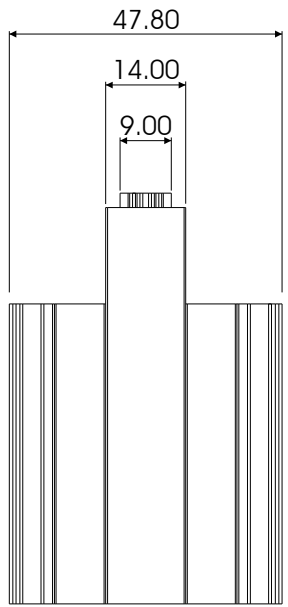
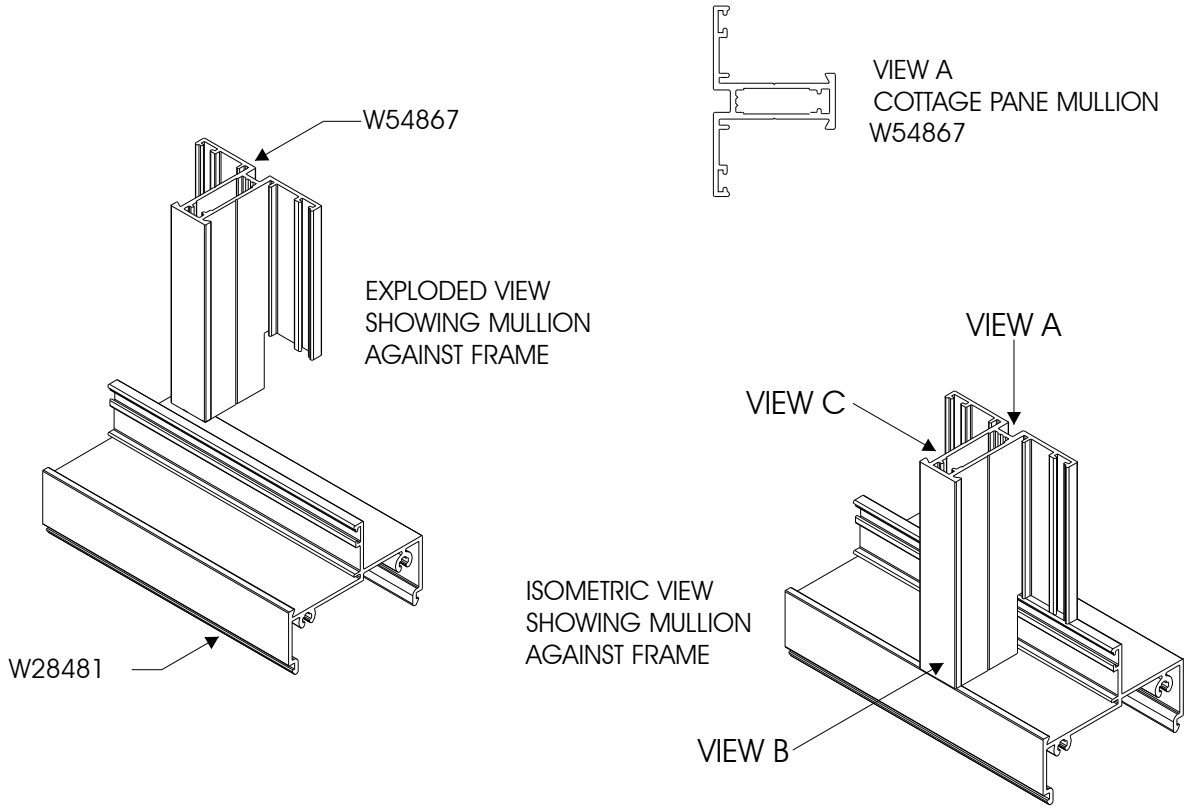

VIEW B

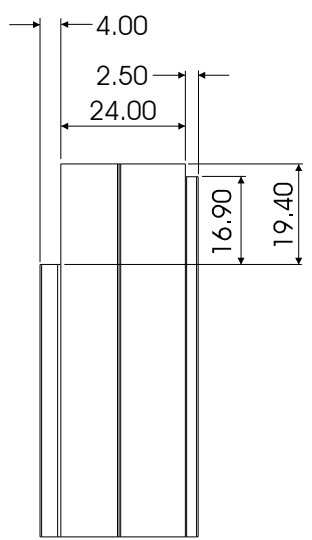

VIEW C



CASEMENT 30.5
 WINDOW
 COTTAGE PANE MULLION
 MACHINING DETAIL FOR END MILLING
 ON 70mm OUTER FRAME

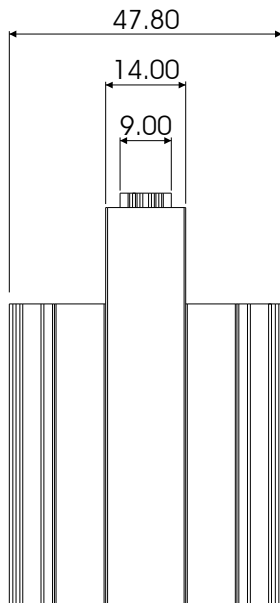
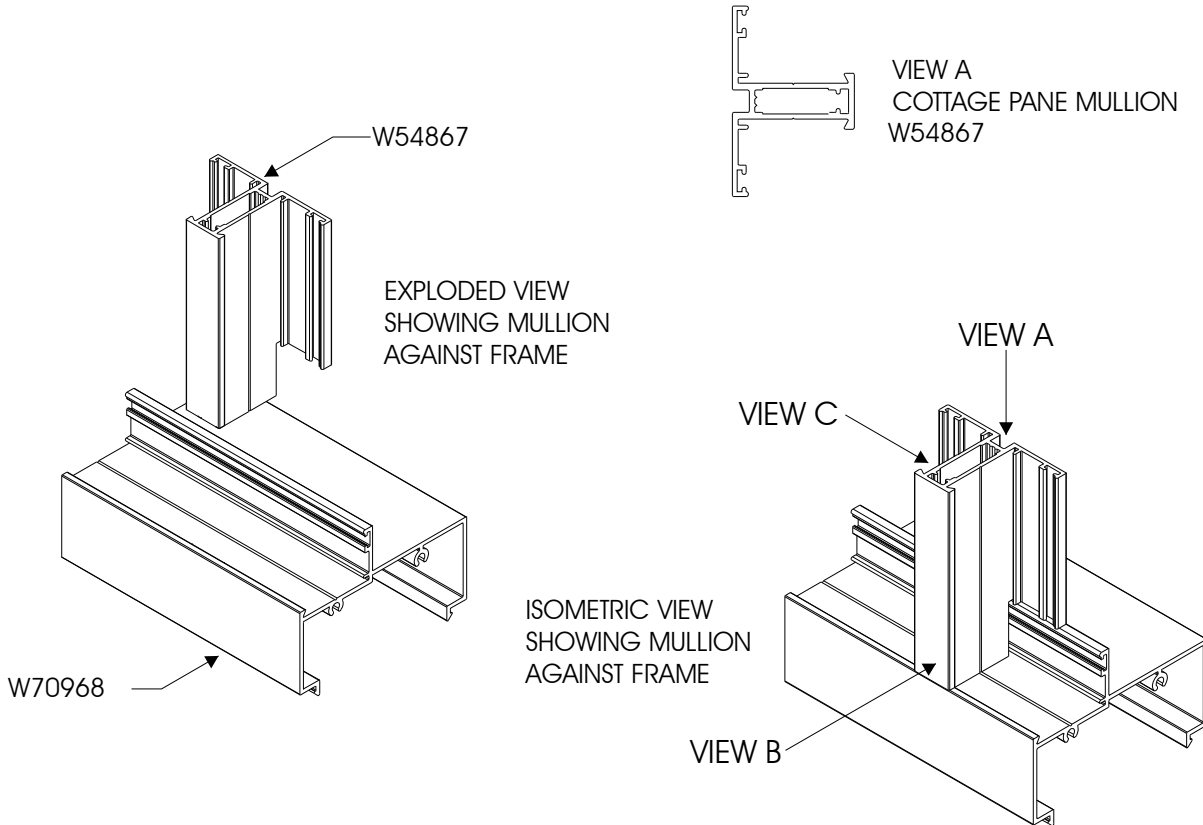

VIEW B

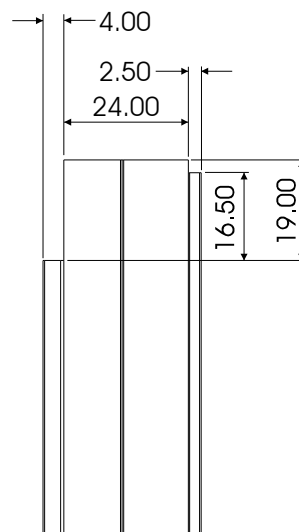

VIEW C

CASEMENT 30.5
 WINDOW
 COTTAGE PANE MULLION
 MACHINING DETAIL FOR END MILLING
 ON LITE EQUAL LEG OUTER FRAME

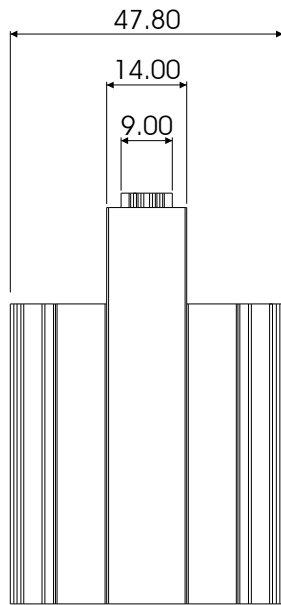
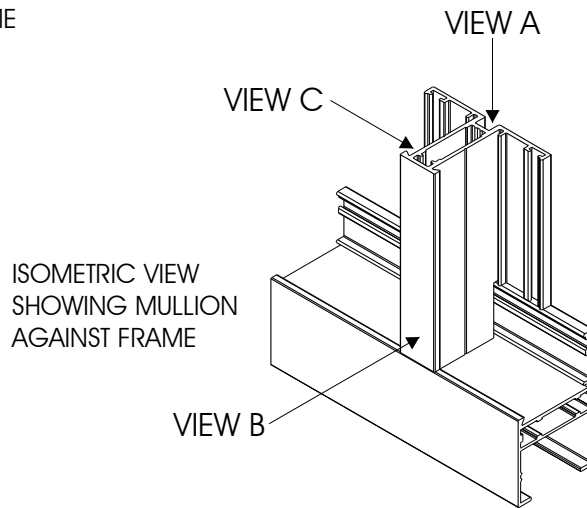
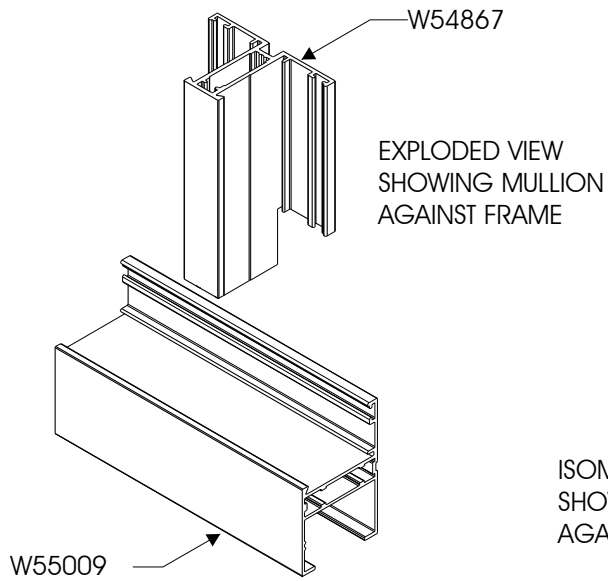

VIEW B

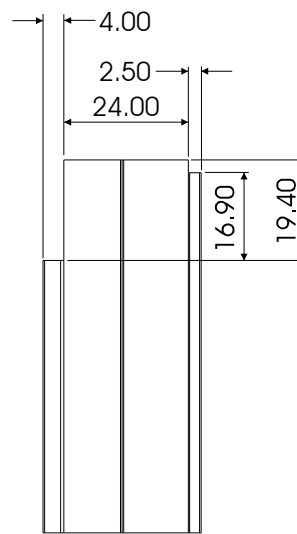

VIEW C

CASEMENT 30.5
 WINDOW
 LITE MULLION MACHINING
 DETAIL FOR END MILLING
 ON EQUAL LEG OUTER FRAME

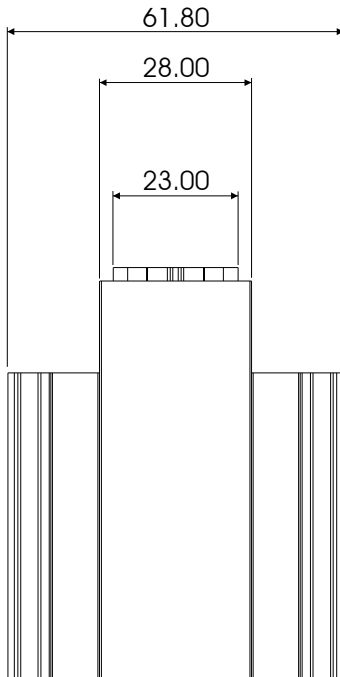
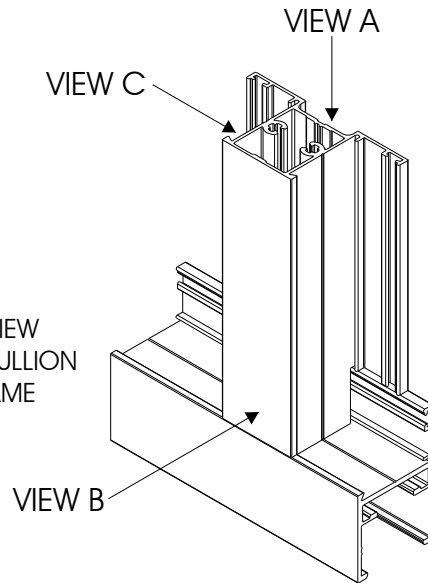
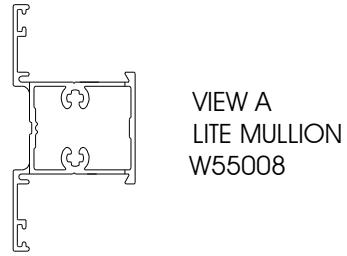
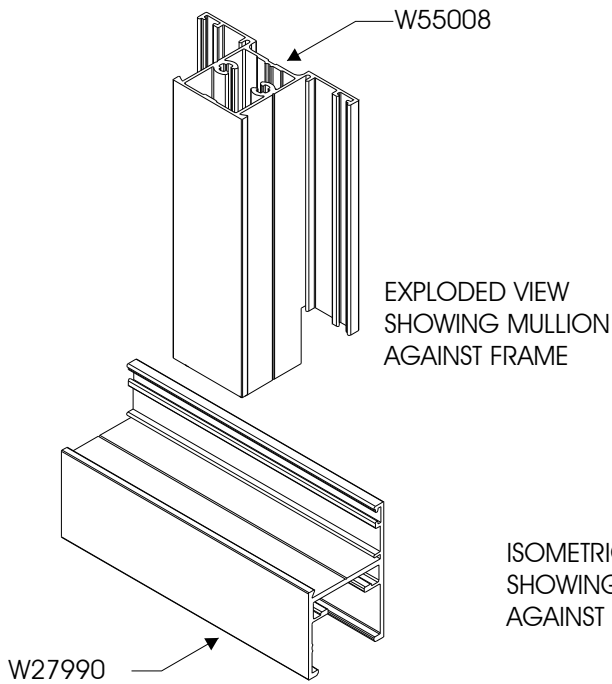

VIEW B

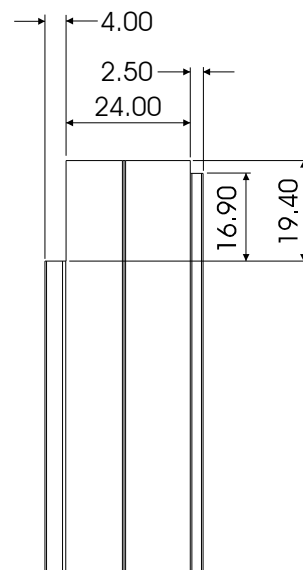

VIEW C

CASEMENT 30.5
 WINDOW
 LITE MULLION MACHINING
 DETAIL FOR END MILLING
 ON UNEQUAL LEG OUTER FRAME

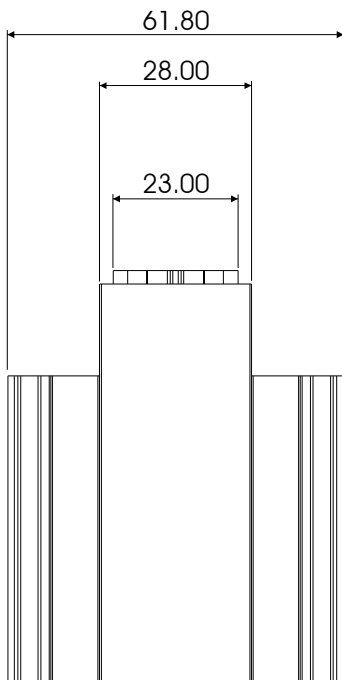
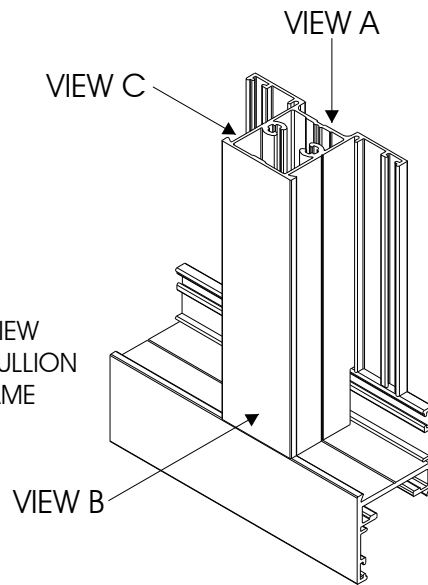
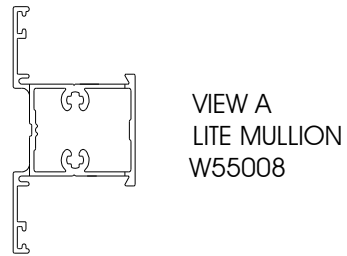
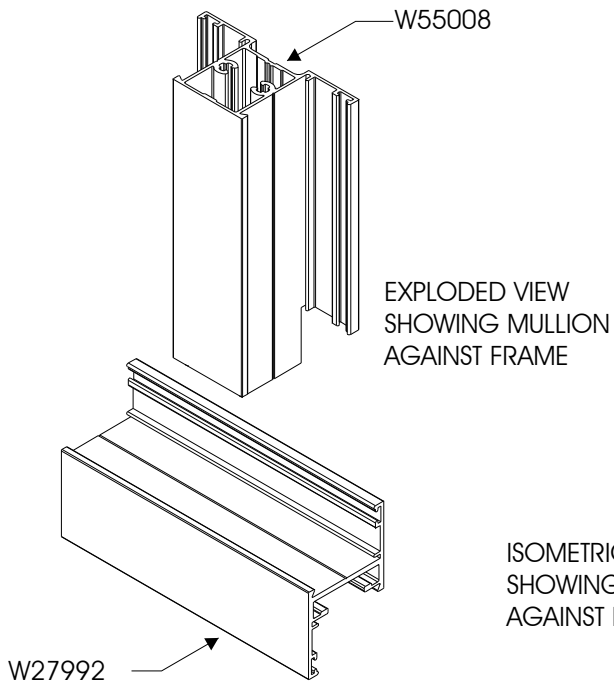

VIEW B

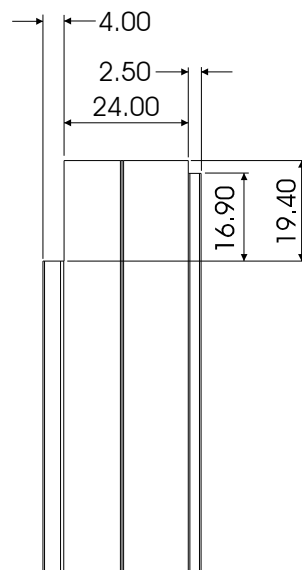

VIEW C

CASEMENT 30.5
 WINDOW
 LITE MULLION MACHINING
 DETAIL FOR END MILLING
 ON 54mm OUTER FRAME

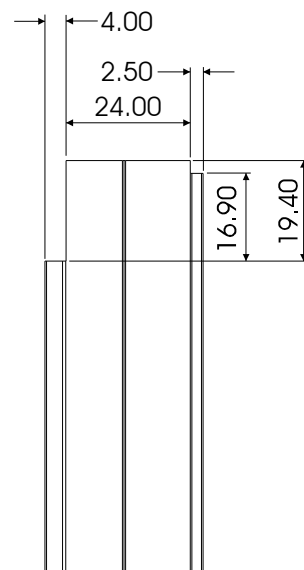
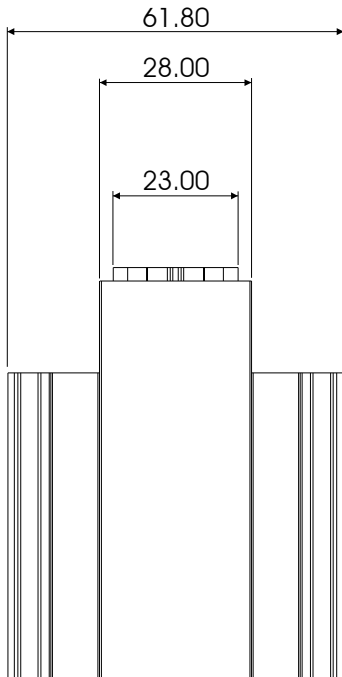
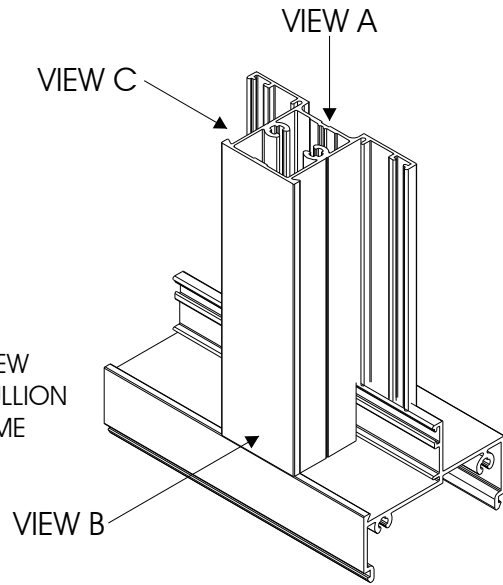
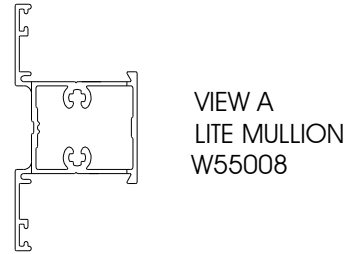
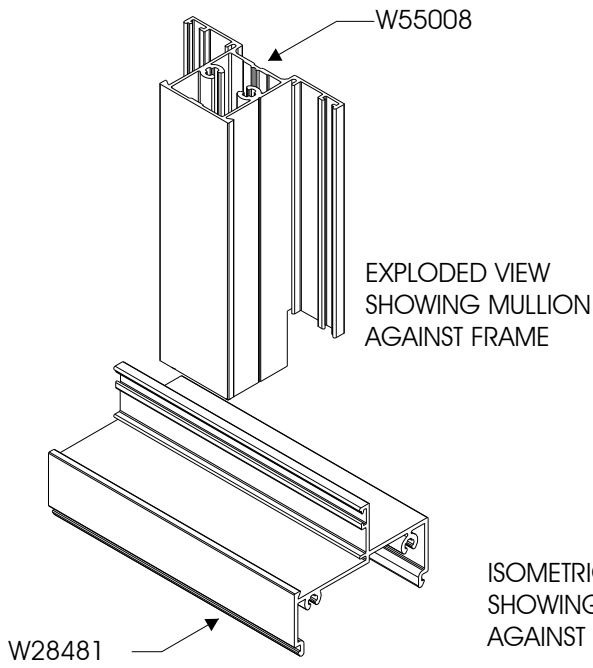

CASEMENT 30.5
 WINDOW
 LITE MULLION MACHINING
 DETAIL FOR END MILLING
 ON 70mm OUTER FRAME

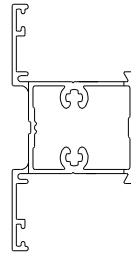
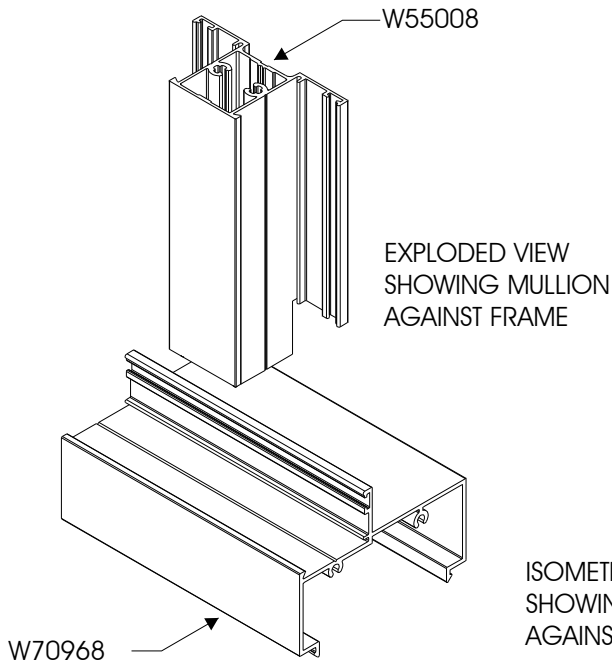

VIEW A
 LITE MULLION
 W55008

ISOMETRIC VIEW
 SHOWING MULLION
 AGAINST FRAME

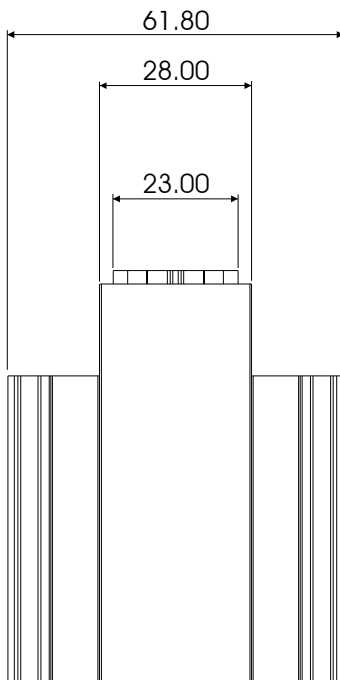
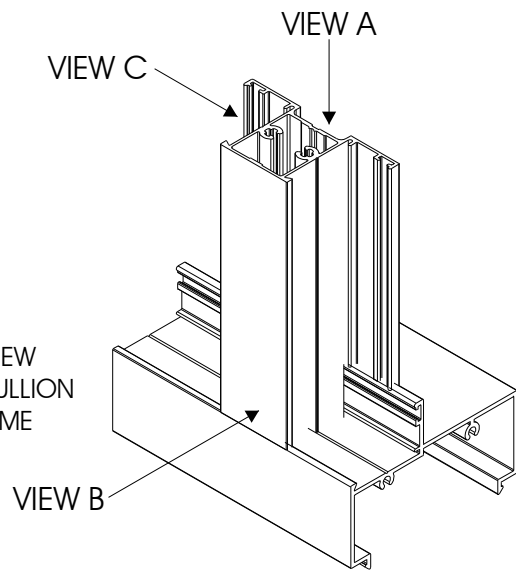

VIEW B

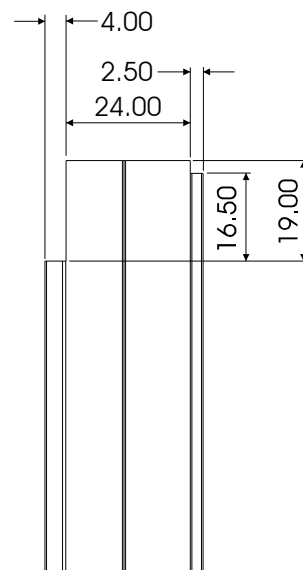

VIEW C

CASEMENT 30.5
 WINDOW
 LITE MULLION MACHINING
 DETAIL FOR END MILLING
 ON LITE EQUAL LEG OUTER FRAME

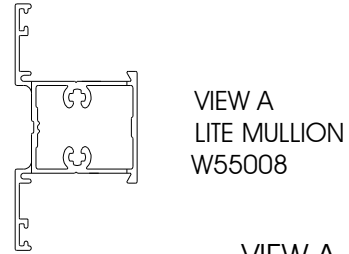
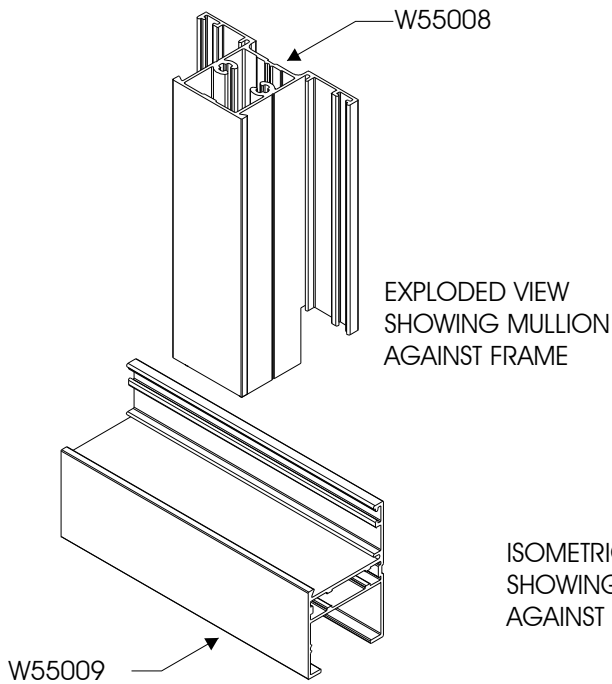

ISOMETRIC VIEW
 SHOWING MULLION
 AGAINST FRAME

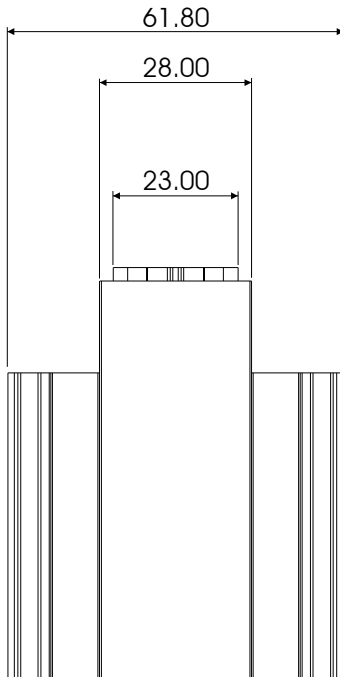
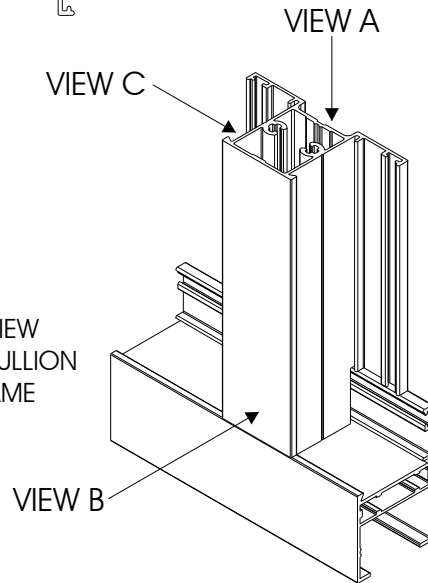

VIEW B

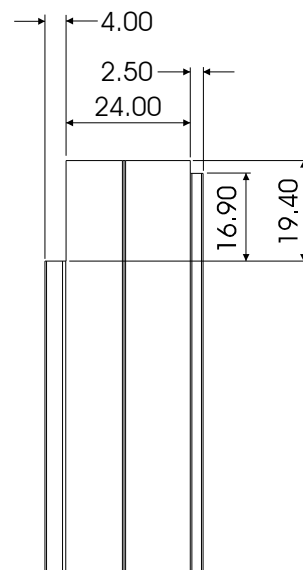

VIEW C

CASEMENT 30.5
 WINDOW
 CORNER CLEAT ASSEMBLY DETAIL
 FOR TUBULAR SASH

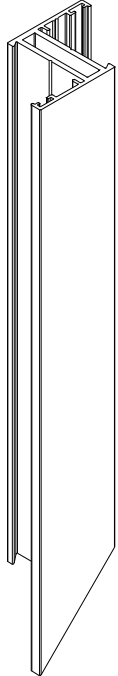

NOTE:
 ALL JOINTS MUST BE SEALED WITH
 SMALL JOINT SEALANT. FINPILE
 MUST BE FITTED TO SASH AND
 CORRESPONDING SURFACES OF
 FRAME BEFORE CRIMPING (NOT
 TO AREAS TO BE GLAZED)

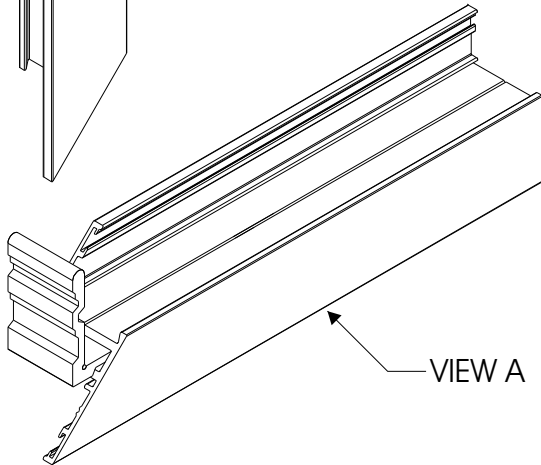

VIEW A

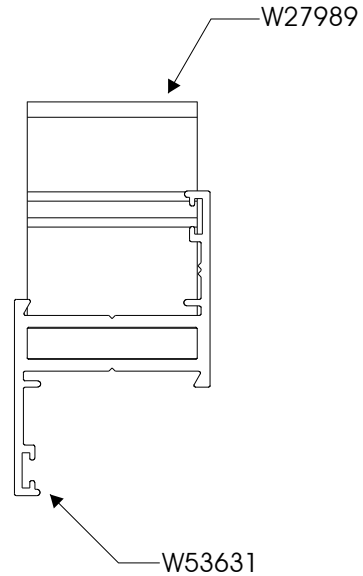

W27989

W53631

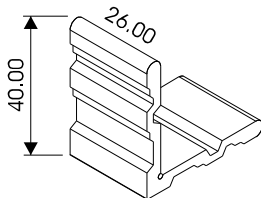

W27989

THE CORNER CLEAT HAS BEEN
 SPECIALLY DESIGNED SO THAT THE
 CORNER CAN BE CRIMPED EITHER
 FROM THE INSIDE WITH A HAND
 OPERATED CRIMPING MACHINE
 OR FROM THE OUTSIDE WITH A
 HYDRAULICALLY OPERATED
 CRIMPING MACHINE

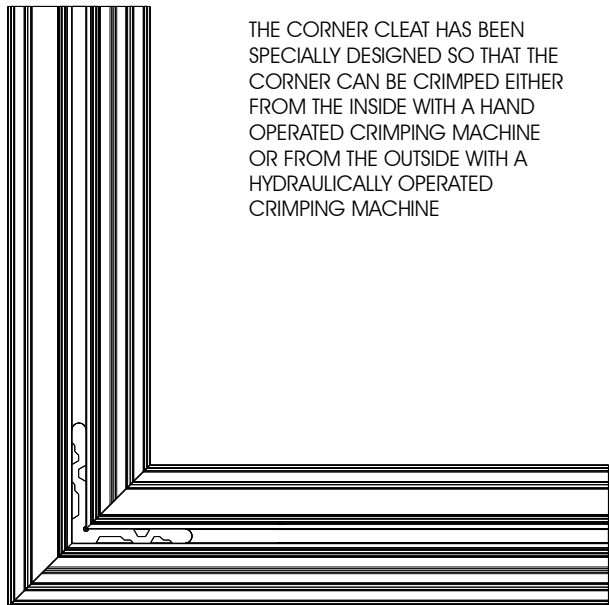

VIEW A

CASEMENT 30.5
 WINDOW
 CORNER CLEAT ASSEMBLY DETAIL
 FOR LITE TUBULAR SASH

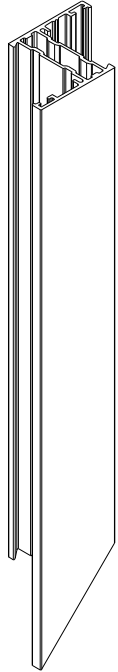

NOTE:
 ALL JOINTS MUST BE SEALED WITH
 SMALL JOINT SEALANT. FINPILE
 MUST BE FITTED TO SASH AND
 CORRESPONDING SURFACES OF
 FRAME BEFORE CRIMPING (NOT
 TO AREAS TO BE GLAZED)

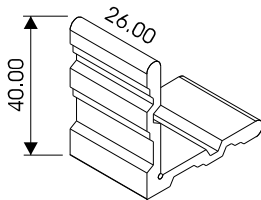
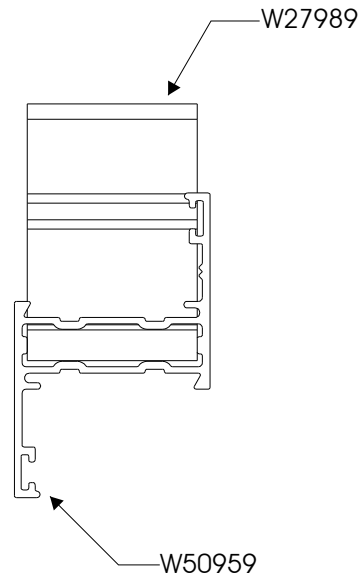
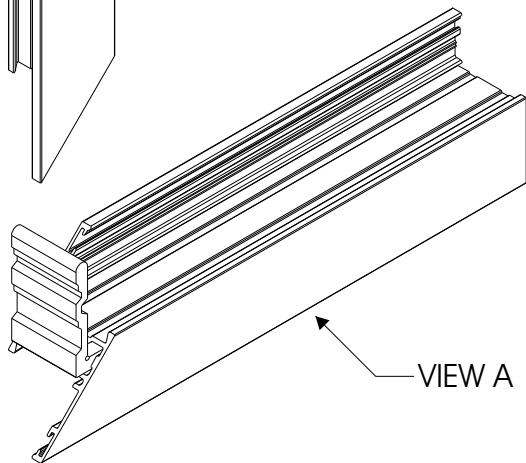

W27989

THE CORNER CLEAT HAS BEEN
 SPECIALLY DESIGNED SO THAT THE
 CORNER CAN BE CRIMPED EITHER
 FROM THE INSIDE WITH A HAND
 OPERATED CRIMPING MACHINE
 OR FROM THE OUTSIDE WITH A
 HYDRAULICALLY OPERATED
 CRIMPING MACHINE

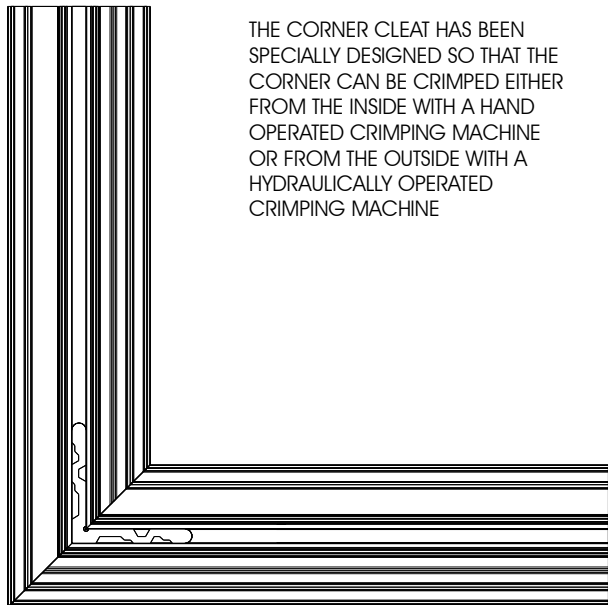

VIEW A

CASEMENT 30.5 WINDOW GLAZING BAR FRAME JOINT ASSEMBLY DETAIL



NOTE: ALL JOINTS MUST BE SEALED WITH SMALL JOINT SEALANT. FINPILE MUST BE FITTED PRIOR TO ASSEMBLY IF SASH IS TO BE FITTED INTO FRAME. FINPLIE MUST NOT RUN BEHIND GLAZING BAR AND GAP MUST BE SEALED TO PREVENT WATER INFILTRATION.

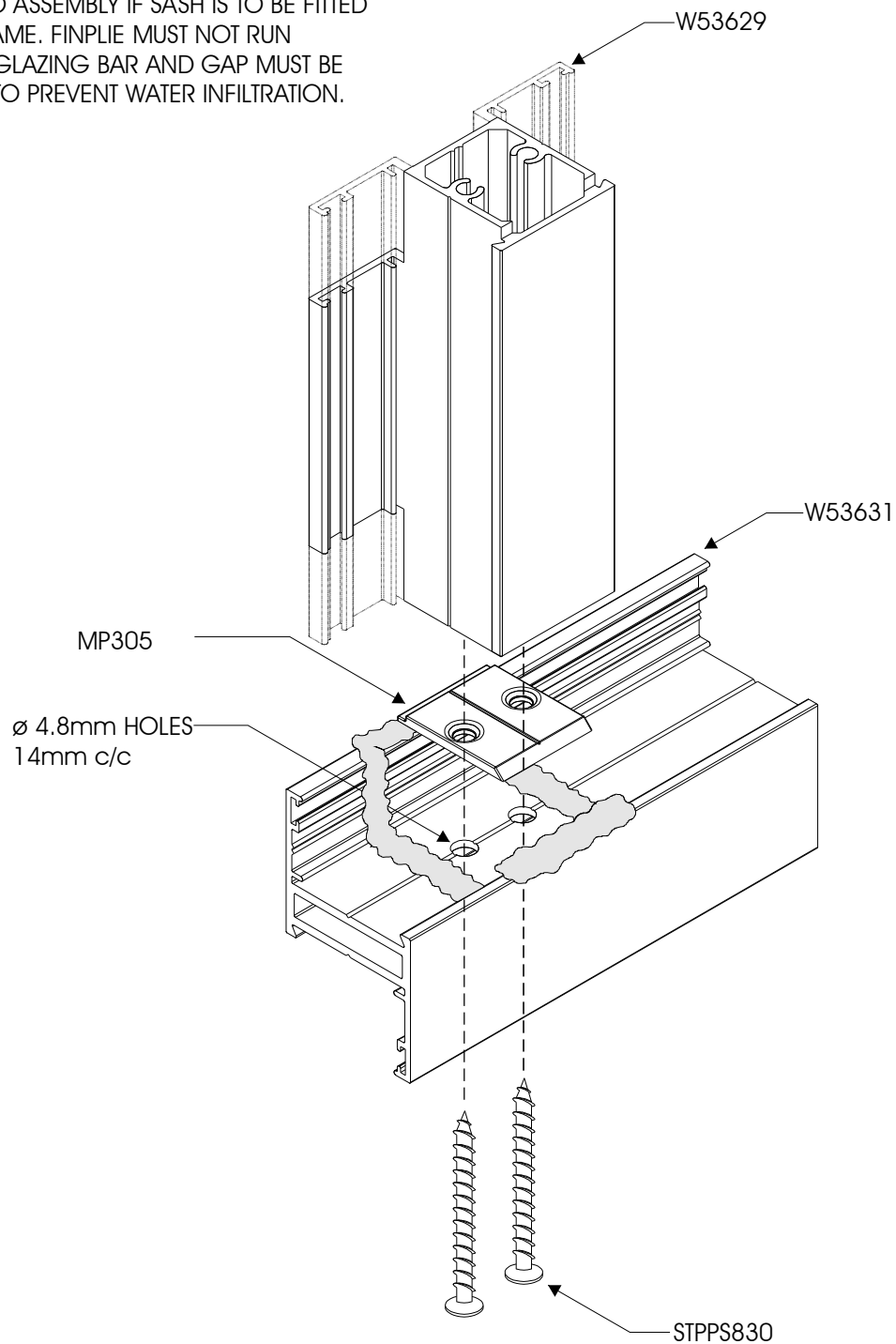

CASEMENT 30.5 WINDOW GLAZING BAR FRAME JOINT ASSEMBLY DETAIL



NOTE: ALL JOINTS MUST BE SEALED WITH SMALL JOINT SEALANT. FINPILE MUST BE FITTED PRIOR TO ASSEMBLY IF SASH IS TO BE FITTED INTO FRAME. FINPLIE MUST NOT RUN BEHIND GLAZING BAR AND GAP MUST BE SEALED TO PREVENT WATER INFILTRATION.

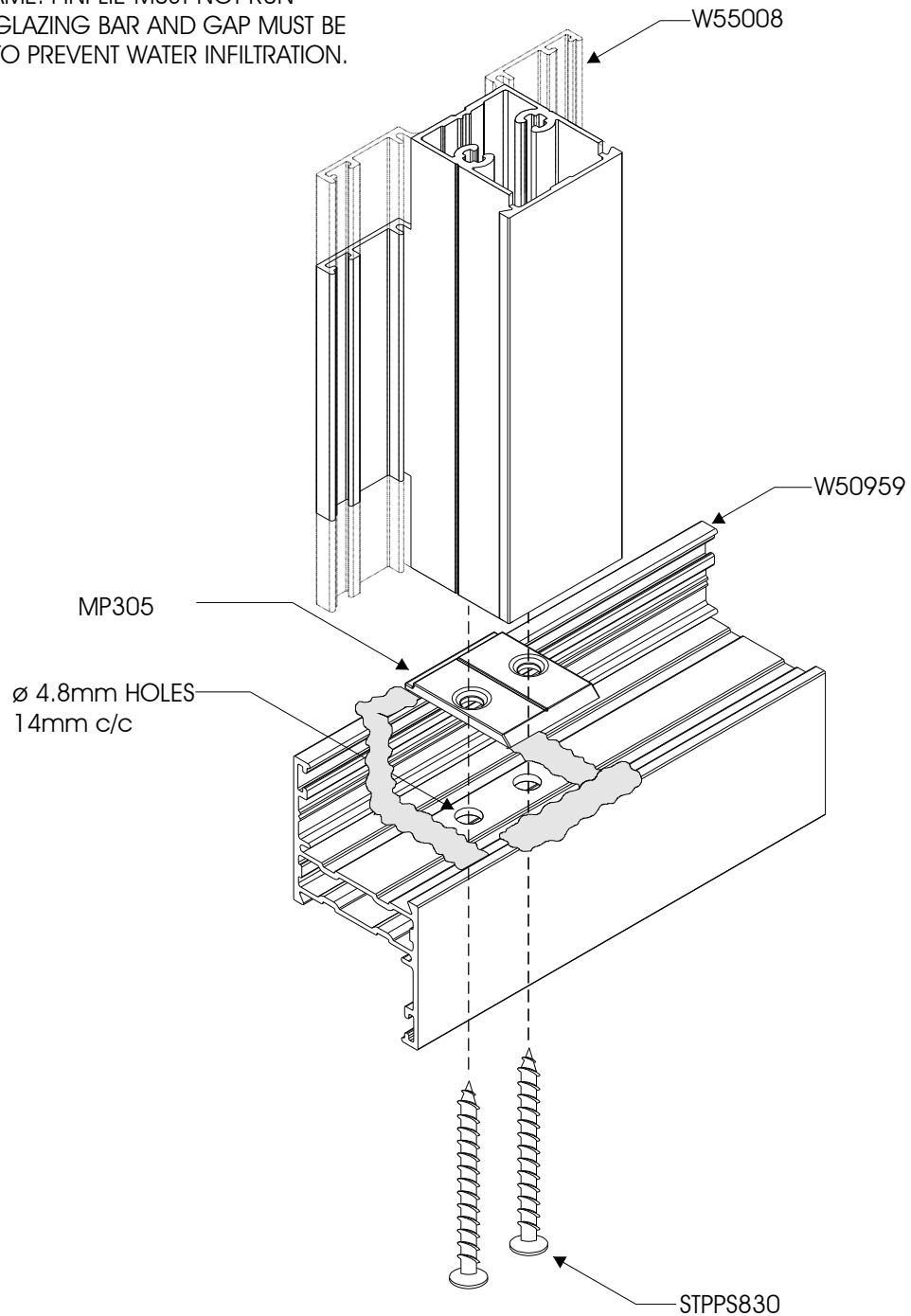

CASEMENT 30.5 WINDOW CROSS JOINT ASSEMBLY DETAIL STANDARD MULLION



NOTE: ALL JOINTS MUST BE SEALED WITH SMALL JOINT SEALANT. FINPILE MUST BE FITTED PRIOR TO ASSEMBLY IF SASH IS TO BE FITTED INTO FRAME. FINPILE MUST NOT RUN BEHIND GLAZING BAR AND GAP MUST BE SEALED TO PREVENT WATER INFILTRATION.

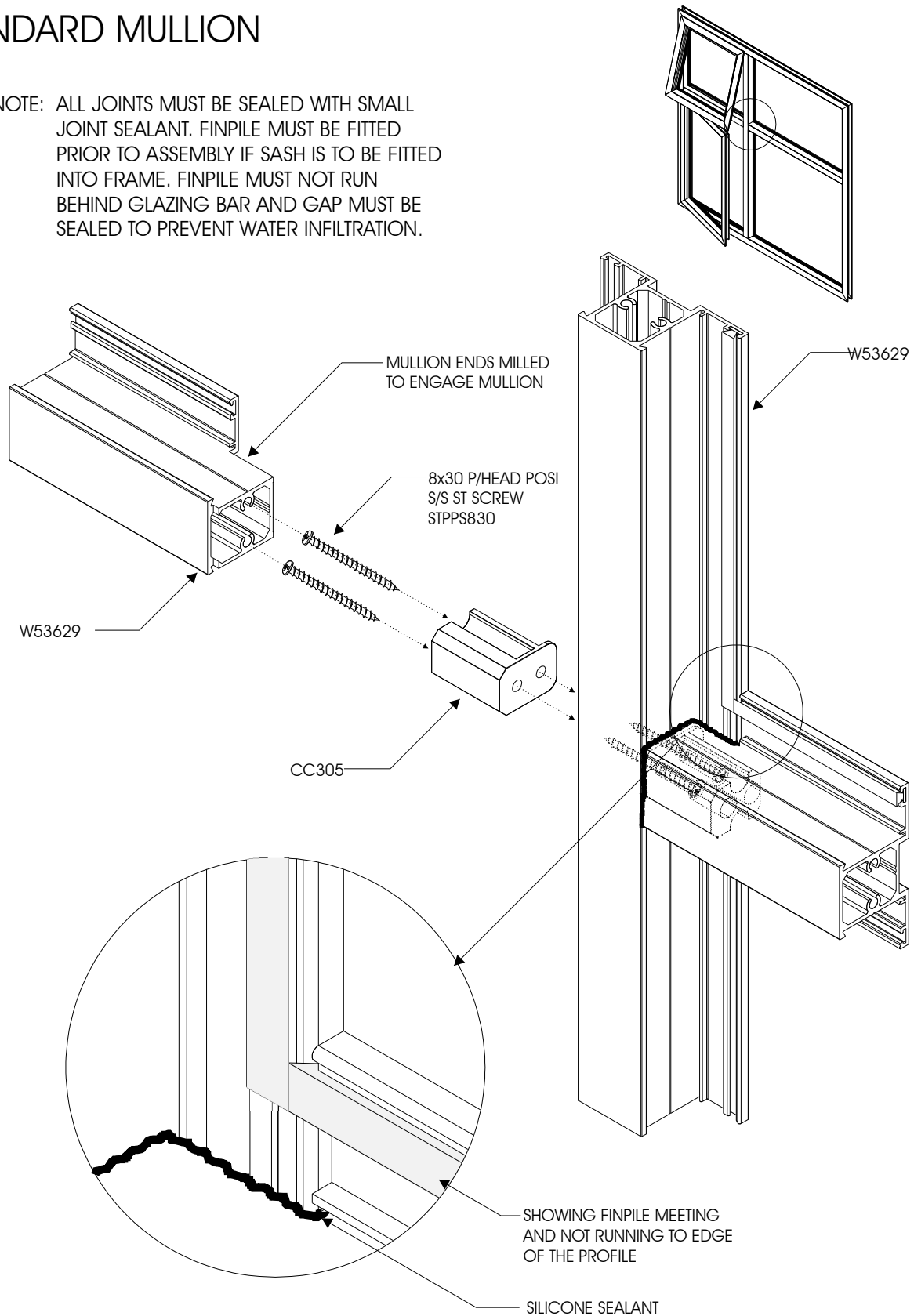

CASEMENT 30.5 WINDOW CROSS JOINT ASSEMBLY DETAIL LITE MULLION



NOTE: ALL JOINTS MUST BE SEALED WITH SMALL JOINT SEALANT. FINPILE MUST BE FITTED PRIOR TO ASSEMBLY IF SASH IS TO BE FITTED INTO FRAME. FINPILE MUST NOT RUN BEHIND GLAZING BAR AND GAP MUST BE SEALED TO PREVENT WATER INFILTRATION.

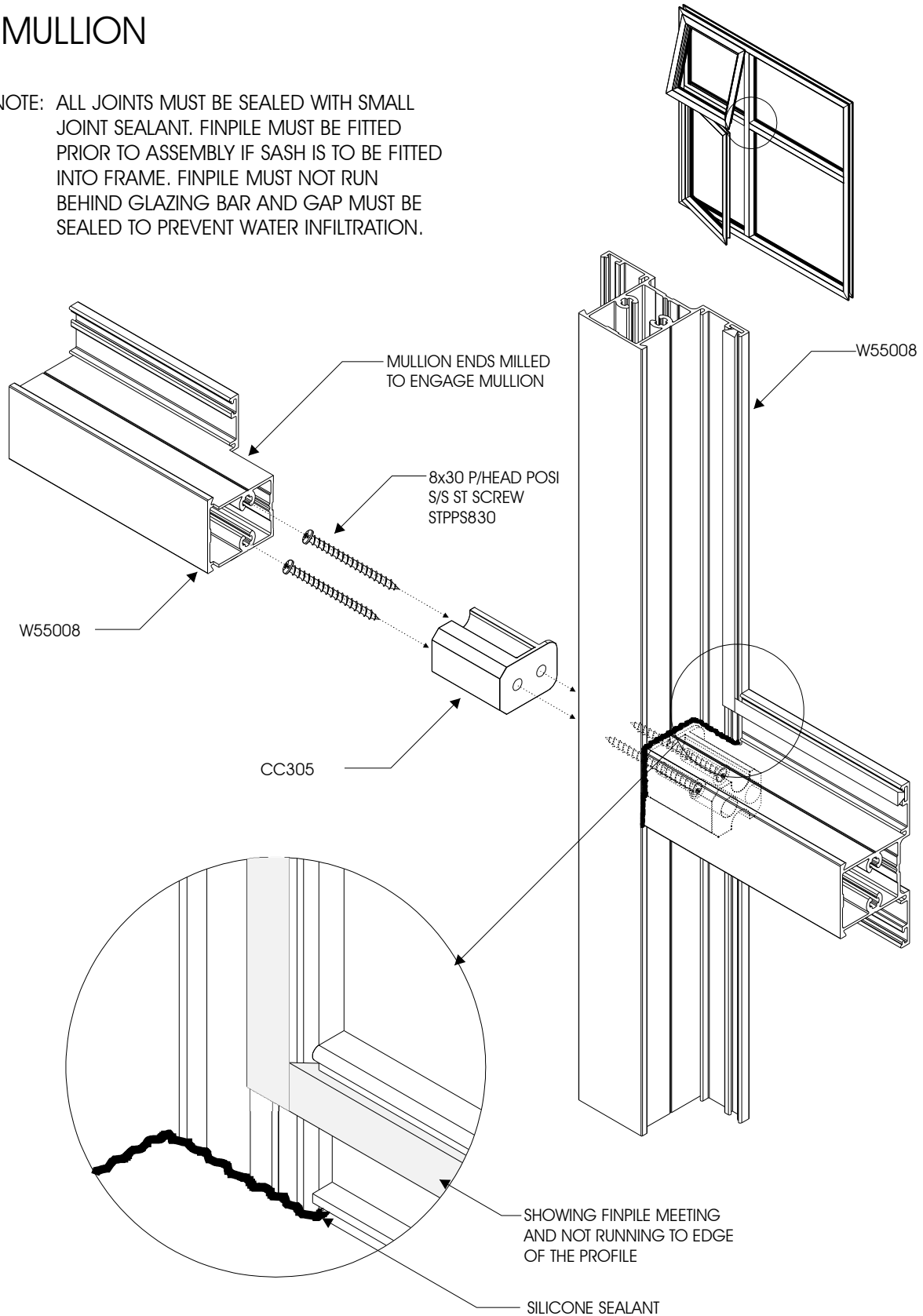

CASEMENT 30.5
 WINDOW
 CROSS JOINT ASSEMBLY DETAIL
 COTTAGE PANE MULLION

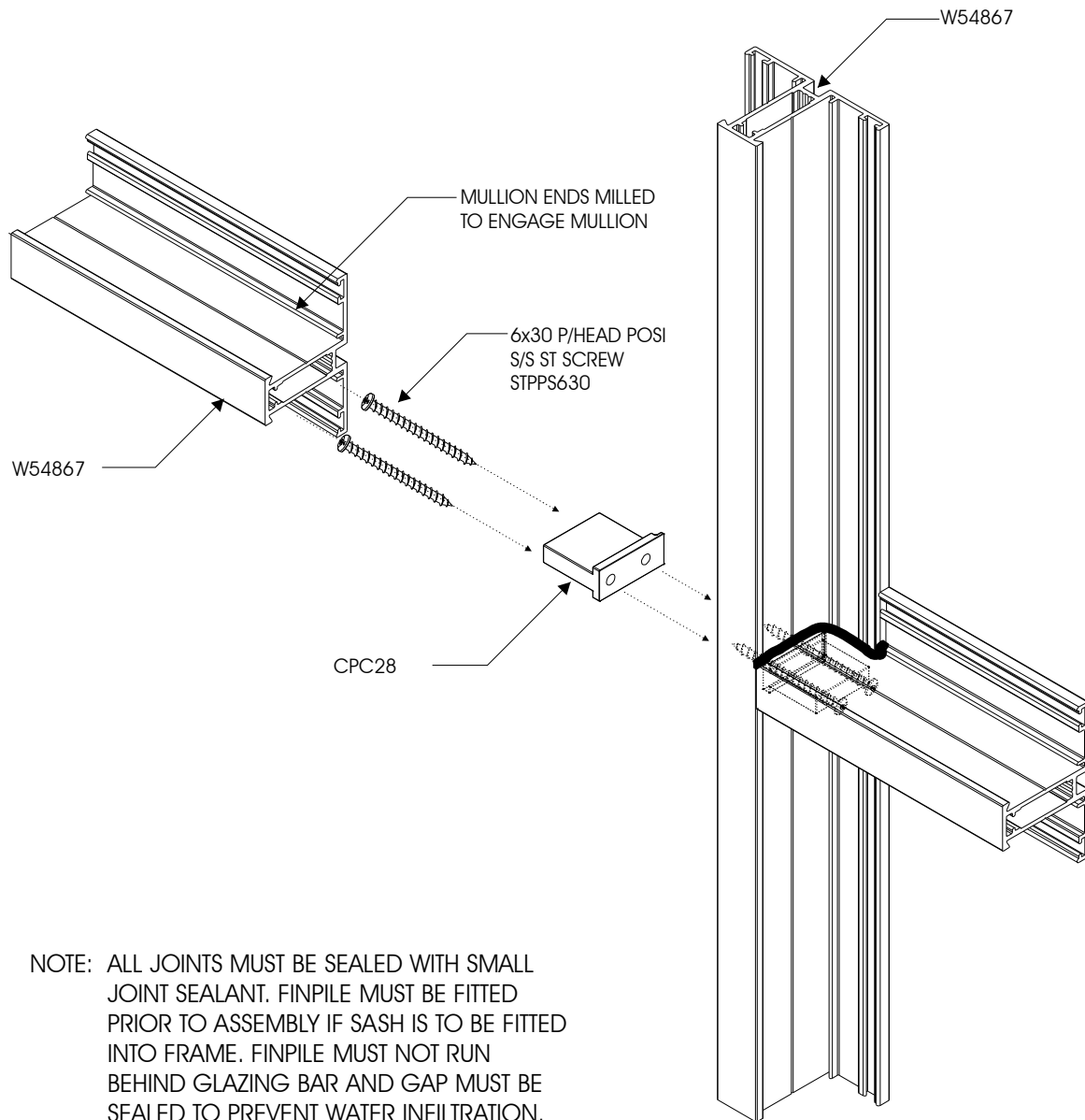

CASEMENT 30.5 WINDOW GLAZING PROCEDURE



Insert the pull-in vinyl gasket into glazing beads by sliding or pressing it into the groove (1). Before cutting gasket, ensure that it has not stretched and cut 6mm longer so that corners are in compression at all times.

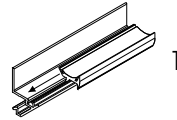

Position bottom glazing bead in glazing bead rebate (2).

Place glass on glazing blocks (3).

Insert top and then side glazing beads ensuring that they are in correctly.

Starting from top centre, insert roll in gasket (4) without stretching it (5). Stop 150mm from corner and partly cut gasket 6mm longer than the edge of the vertical bead. Insert gasket at corner and then roll in remaining 150mm. Repeat this on the other sides. Where gasket ends meet, cut gasket 6mm longer. Insert cut ends first and complete.

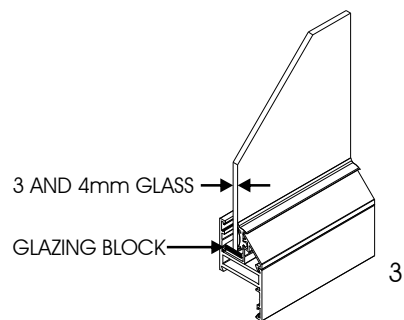
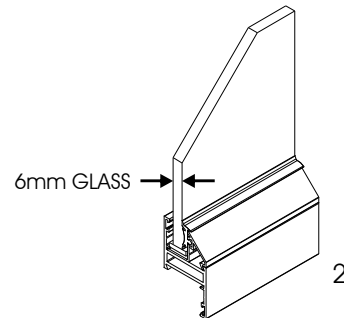

ENSURE GASKETS ARE NOT STRETCHED AT ANY STAGE

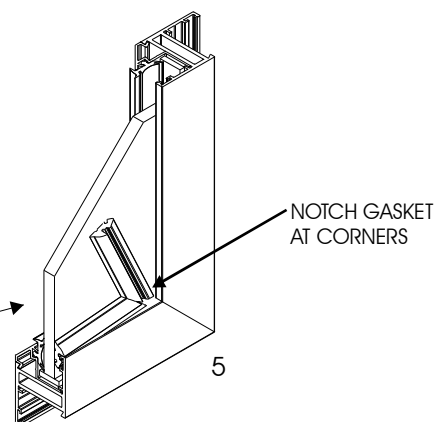
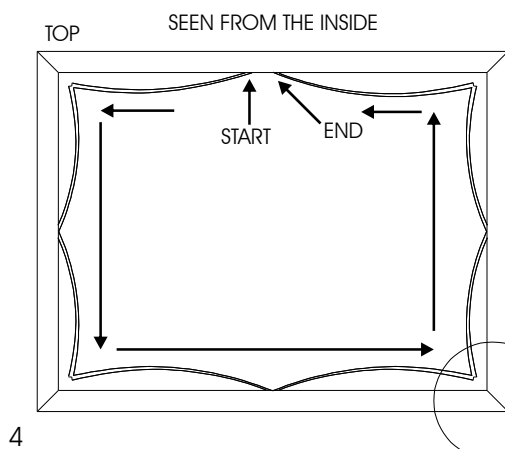

CASEMENT 30.5 WINDOW GLAZING PROCEDURE

GLAZING

1. SELECTION OF GLAZING METHODS

1.1 SETTING AND LOCATION BLOCKS

Glass-to-metal contact must be avoided at all times by using setting and location blocks having a hardness of 50° to 90° shore A durometer. Use only blocks made of Neoprene, EPDM, Silicone or other elastomeric material.

Setting blocks are to have a minimum thickness of 3mm and must be at least 27mm in length per square metre of glass area.

The position of the setting and location blocks is illustrated in Figure 2.

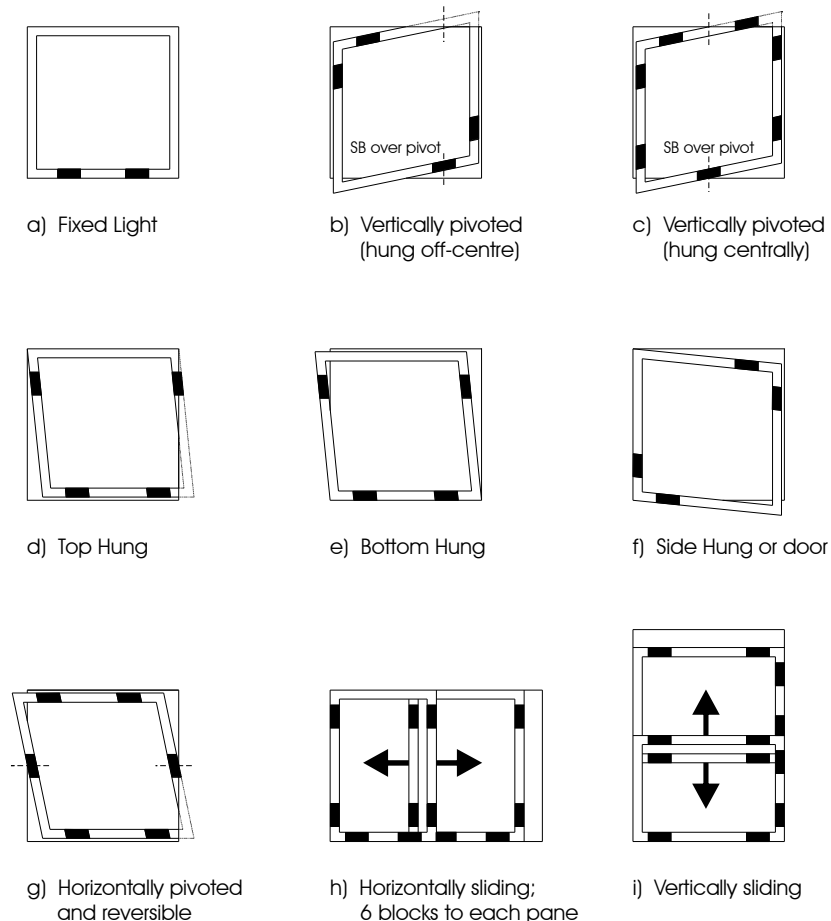
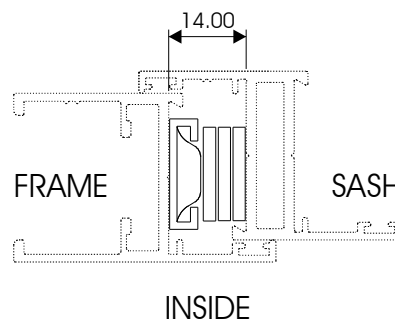
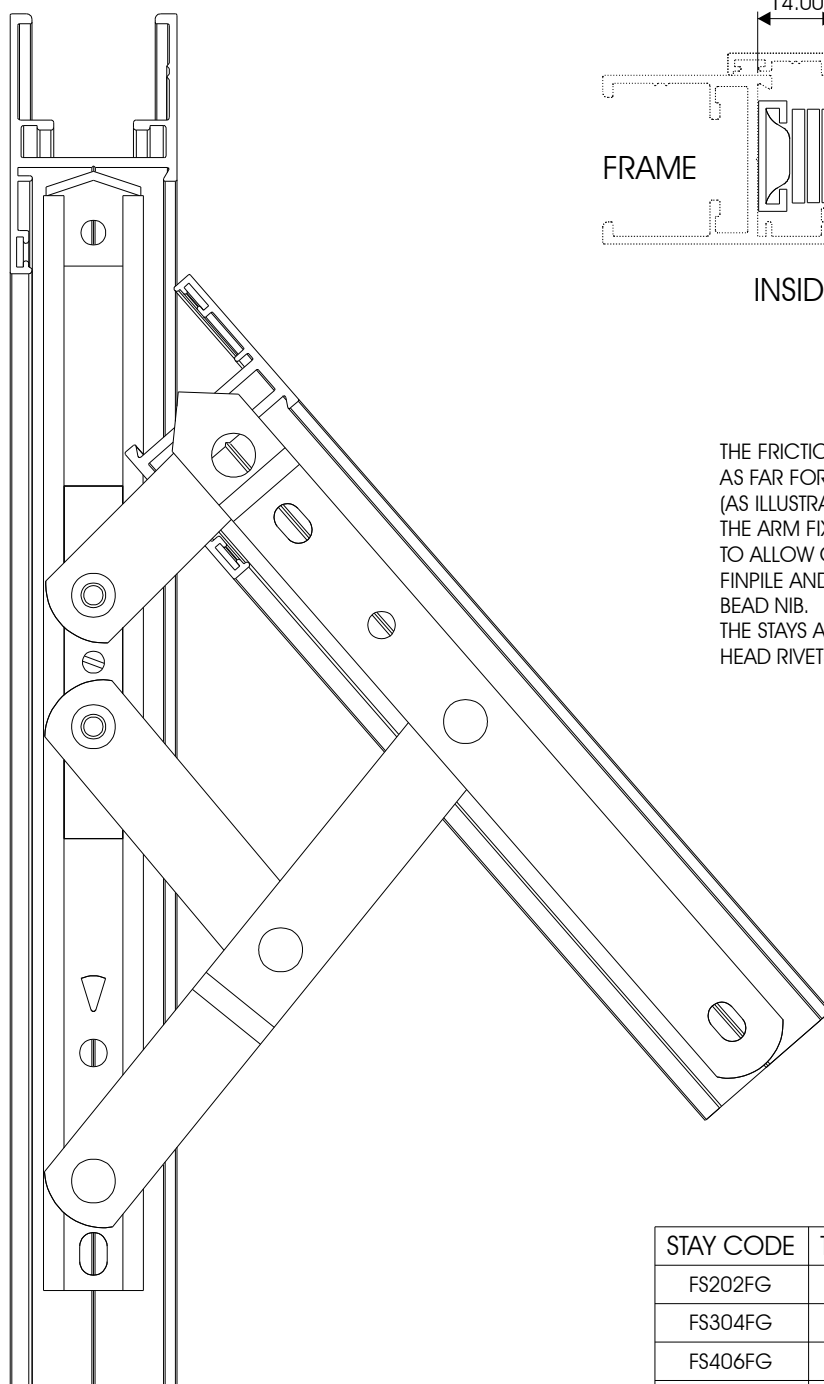

FIGURE 2 - POSITION OF SETTING AND LOCATION BLOCKS

CASEMENT 30.5
 WINDOW
 FRICTION STAY ASSEMBLY DETAIL



THE FRICTION STAY SHOULD ALWAYS BE FITTED AS FAR FORWARD IN THE FRAME AS POSSIBLE. (AS ILLUSTRATED)
 THE ARM FIXED TO THE SASH SHOULD BE FITTED TO ALLOW CORRECT COMPRESSION OF THE FINPILE AND PACKED TO CLEAR GLAZING BEAD NIB.
 THE STAYS ARE SECURED WITH 4.8 x 10 DOME HEAD RIVETS.

STAY CODE	TO BE USED FOR SASH SIZE
FS202FG	LESS THAN OR EQUAL TO 300mm
FS304FG	BETWEEN 301mm AND 450mm
FS406FG	BETWEEN 451mm AND 600mm
FS508FG	BETWEEN 601mm AND 750mm
FS600FG	GREATER THAN 750mm

CASEMENT 30.5 WINDOW HANDLE ASSEMBLY DETAIL

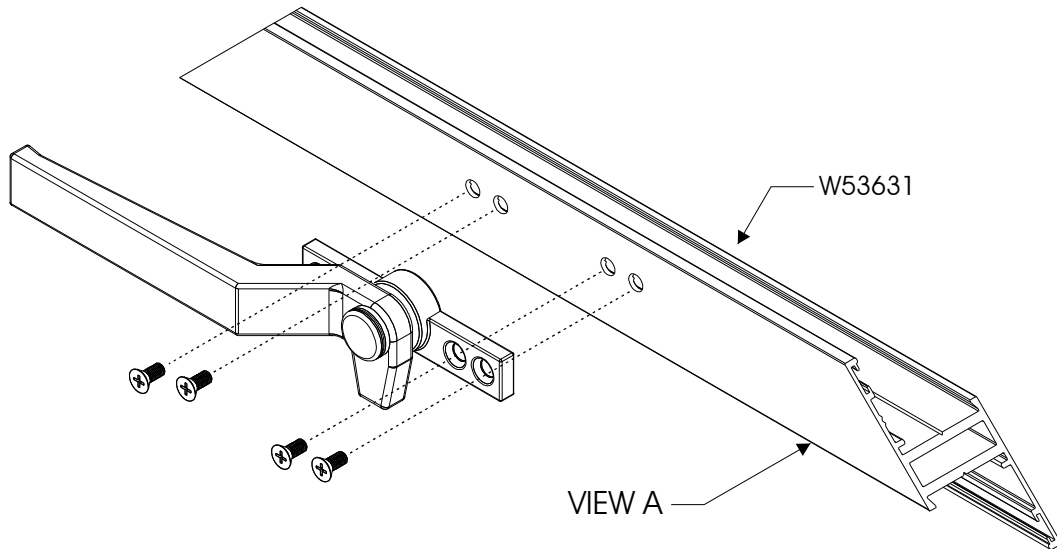

NO 8 x 10 COUNTERSUNK SELF-TAPPING
FLAT END SCREWS

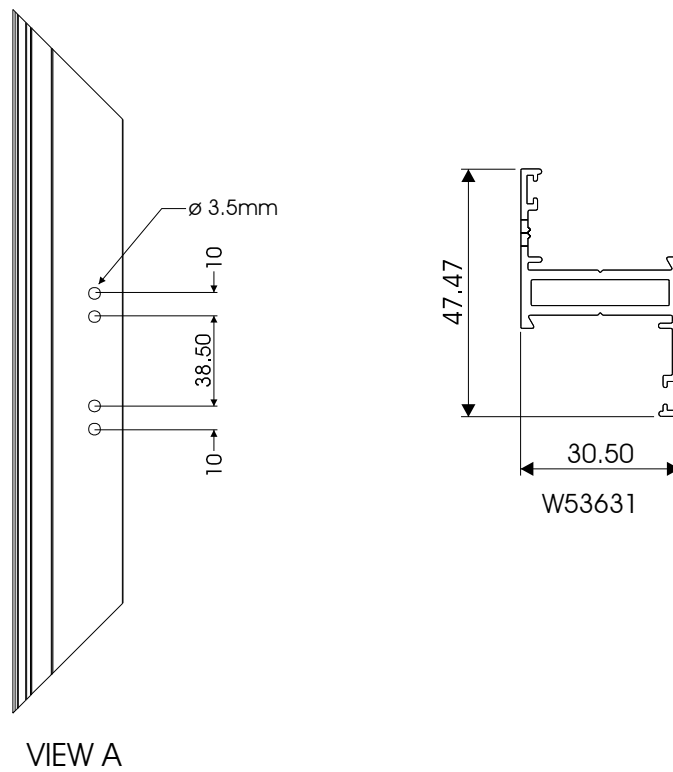

CASEMENT 30.5
WINDOW
FIXING LUG PREPARATION DETAIL

