

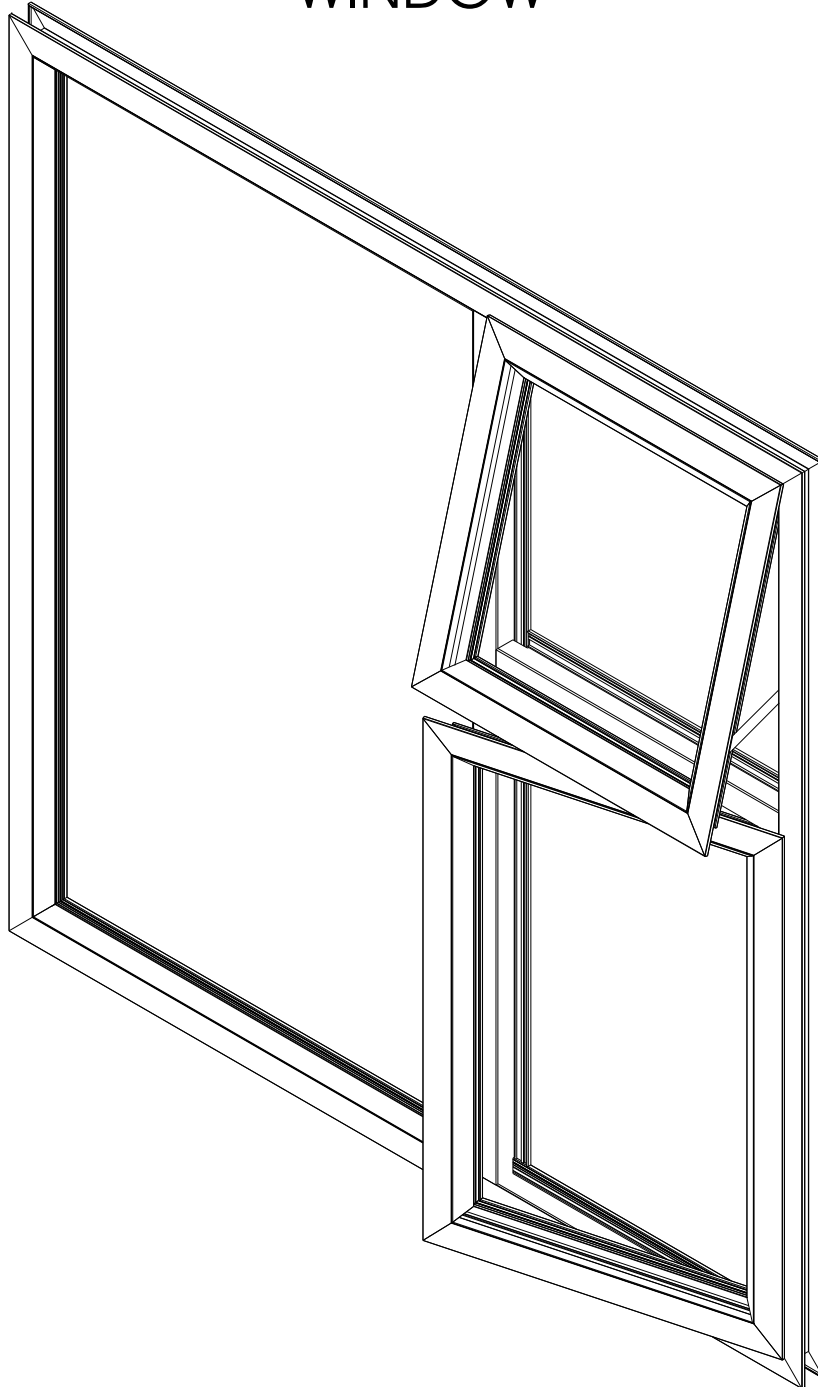

crealco | CASEMENT 28

CASEMENT 28 WINDOW



PRODUCT MANUAL

Disclaimer: The right to make alterations is reserved
© 2013 Wispeco (Pty) Ltd, All Rights Reserved
Revision: October 2013



Index

Legal Disclaimer	5
Profile Identification	6-8
Hardware Identification	9
Butterfly Gasket and Wedge Codes	10
Sash Limitation Charts	11
Standard Top Hung Windows 600Pa Windload	12
Standard Top Hung Windows 1000Pa Windload	13
Standard Top Hung Windows 1500Pa Windload	14
Standard Side Hung Windows 600Pa Windload	15
Standard Side Hung Windows 1000Pa Windload	16
Standard Side Hung Windows 1500Pa Windload	17
Standard Top Hung Window Typical Configurations	18
Standard Side Hung Window Typical Configurations	19
Cottage Pane Window Fixed Panel Typical Configurations	20
Cottage Pane Window Top Hung & Side Hung Typical Configurations	21
Typical Coupling Configurations	22
Fastening Positions	23
Typical Cross Sectional Detail Double Top Hung Over Fixed	24
Typical Cross Sectional Detail Double Side Hung Over Fixed	25
Cottage Pane Typical Cross Section Detail 2 x 2 Hung Over 2 x 1 Fixed Panel	26
Lite Window System Typical Cross Sectional Detail Side Over Fixed	27
Outer Frame Component Assembly Detail	28
Sash Frame Component Assembly Detail	29
Equal Leg Outer Frame Sill Level & Machining Detail	30
Unequal Leg Outer Frame Sill Level & Machining Detail	31
54mm Outer Frame Sill Level & Machining Detail	32
70mm Outer Frame Sill Level & Machining Detail	33
Tubular Equal Leg Outer Frame Sill Level & Machining Detail	34
Standard Mullion Machining Detail for End Milling On Equal Leg Outer Frame	35
Standard Mullion Detail for End Milling On Unequal Leg Outer Frame	36
Standard Mullion Machining Detail for End Milling on 54mm Outer Frame	37
Standard Mullion Machining Detail for End Milling On 70mm Outer Frame	38

This manual must be read in conjunction with the Installation, Cleaning and Maintenance Document, BEE Certificates and the Performance Certificates for the relevant system. The manual must also be used in conjunction with the design and cutting list from the latest version of StarFront.



Index

Standard Mullion Machining Detail for End Milling On Tubular Equal Leg Outer Frame	39
Transom With W/Bar Machining Detail for End Milling On Equal Leg Outer Frame	40
Transom With W/Bar Machining Detail for End Milling On Unequal Leg Outer Frame	41
Transom With W/Bar Machining Detail for End Milling On 54mm Outer Frame	42
Transom With W/Bar Machining Detail for End Milling On 70mm Outer Frame	43
Transom With W/Bar Machining Detail for End Milling On Tubular Equal Leg Outer Frame	44
54mm Mullion Machining Detail for End Milling On Equal Leg Outer Frame	45
54mm Mullion Machining Detail for End Milling On Unequal Leg Outer Frame	46
54mm Mullion Machining Detail for End Milling On 54mm Outer Frame	47
54mm Mullion Machining Detail for End Milling On 70mm Outer Frame	48
54mm Mullion Machining Detail for End Milling On Tubular Equal Leg Outer Frame	49
70mm Mullion Machining Detail for End Milling On Equal Leg Outer Frame	50
70mm Mullion Machining Detail for End Milling On Unequal Leg Outer Frame	51
70mm Mullion Machining Detail for End Milling On 54mm Outer Frame	52
70mm Mullion Machining Detail for End Milling On 70mm Outer Frame	53
70mm Mullion Machining Detail for End Milling On Tubular Equal Leg Outer Frame	54
Cottage Pane Mullion Machining Detail for End Milling On Equal Leg Outer Frame	55

This manual must be read in conjunction with the Installation, Cleaning and Maintenance Document, BEE Certificates and the Performance Certificates for the relevant system. The manual must also be used in conjunction with the design and cutting list from the latest version of StarFront.



Index

Cottage Pane Mullion Machining Detail for End Milling On Unequal Leg Outer Frame	56
Cottage Pane Mullion Machining Detail for End Milling On 54mm Outer Frame	57
Cottage Pane Mullion Machining Detail for End Milling On 70mm Outer Frame	58
Cottage Pane Mullion Machining Detail for End Milling On Tubular Equal Leg Outer Frame	59
Lite Mullion Machining Detail for End Milling On Equal Leg Outer Frame	60
Lite Mullion Machining Detail for End Milling On Unequal Leg Outer Frame	61
Lite Mullion Machining Detail for End Milling On 54 mm Outer Frame	62
Lite Mullion Machining Detail for End Milling On 70 mm Outer Frame	63
Lite Mullion Machining Detail for End Milling On Tubular Equal Leg Outer Frame	64
Corner Cleat Assembly Detail for Tubular Sash	65
Corner Cleat Assembly Detail for Lite Sash	66
Cross Joint Assembly Detail Standard Mullion	67
Cross Joint Assembly Detail Lite Mullion	68
Cross Joint Assembly Detail Cottage Pane Mullion	69
Glazing Procedure	70-71
Friction Stay Assembly Detail	72
Handle Assembly Detail	73
Fixing Lug Preparation Detail	74

This manual must be read in conjunction with the Installation, Cleaning and Maintenance Document, BEE Certificates and the Performance Certificates for the relevant system. The manual must also be used in conjunction with the design and cutting list from the latest version of StarFront.



LEGAL DISCLAIMER

All information, recommendations or advice contained in this documentation is given in good faith to the best of Wispeco's knowledge and is based on current procedures in effect.

Since the actual use of this documentation by the user is beyond the control of Wispeco, such use is within the exclusive responsibility of the user. Wispeco cannot be held responsible for any loss incurred through incorrect or faulty use of this documentation.

Great care has been taken to ensure that the information provided is correct. Wispeco will accept no responsibility for any errors and/or omissions, which may have inadvertently occurred.

All mechanical joints must be sealed with a Wispeco approved joint sealer.

Laminated glass must not stand in water.

All drawings in the Wispeco Documentation are shown NOT to scale.

Wispeco cannot accept responsibility for the use of standard products since Wispeco does not know where these products are being installed.

The use of anti-magnetic stainless steel screws and pop rivets is recommended to reduce galvanic corrosion in harsh environments.

The hardware recommended in this documentation is suitable for use in most atmospheric environments. When hardware is used in severe coastal environments the manufacturer of the hardware must be consulted.

Fixing lugs on frames must be positioned as per the user manual and used in accordance to the AAAMSA specifications. When profiles are screwed together the screw centers must also be according to the user manual.

All glass used within Wispeco products must comply with SAGGA regulations.

All glazing above 10m from ground level must be signed off by a competent person (Glazing) in accordance with the national building regulations

By continuing to use this documentation you acknowledge that you understand and accept the legal disclaimer.

CASEMENT 28 WINDOW PROFILE IDENTIFICATION

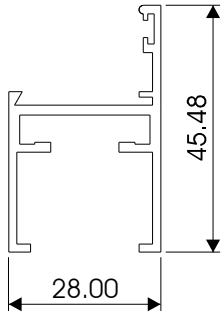

CAS28 FRAME 28mm
EQUAL LEG STD
W52692

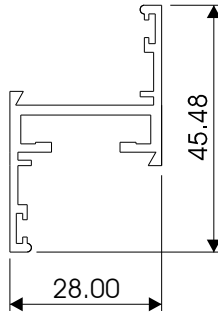

CAS28 FRAME 28mm
UNEQL LEG STD
W52694

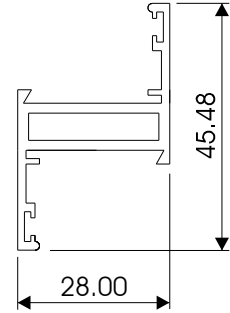

CAS28 SASH STANDARD
W52699

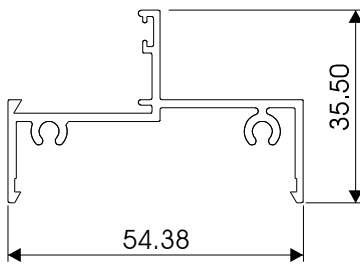

CAS28 FRAME 54mm
W52007

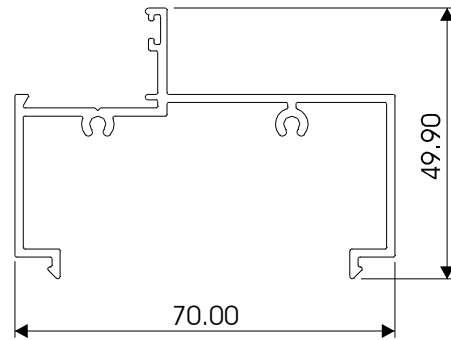

CAS28 FRAME 70mm
W70963

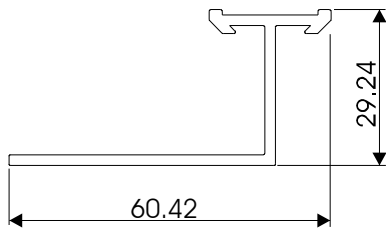

CAS28 FIXING LUG
TWIST IN
W24052

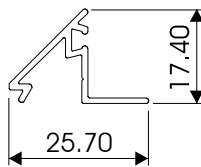

CAS28 BEAD
4mm
W52693

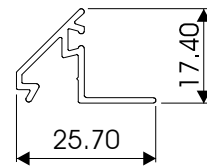

CAS28 BEAD MULTI
12mm GAP
W29697

CASEMENT 28 WINDOW PROFILE IDENTIFICATION

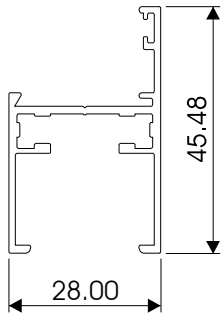

CAS28 FRAME 28mm
EQUAL LEG
W32026

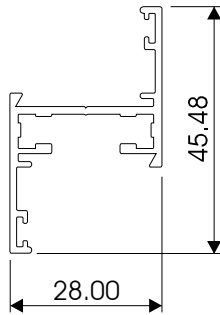

CAS28 FRAME 28mm
UNEQUAL LEG
W32025

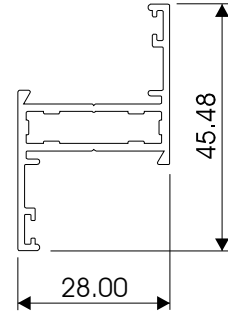

CAS28 SASH TUBULAR
W55682

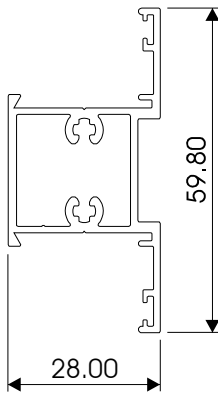

CAS28 MULLION 28mm
W55683

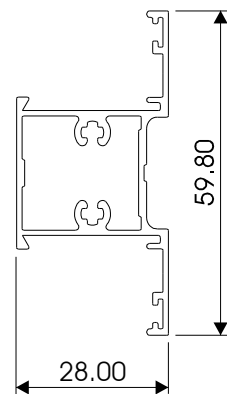

CAS28 MULLION 28mm
ECONO
W50957

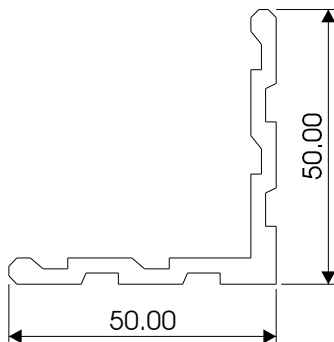

CAS28 CORNER CLEAT
50mm
W52695

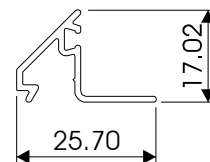

CAS28 BEAD MULTI
13mm GAP
W31137

CASEMENT 28 WINDOW PROFILE IDENTIFICATION

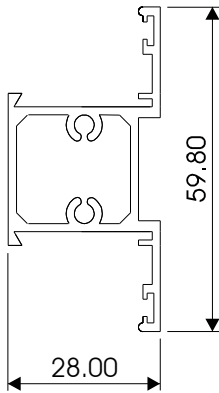

CAS28 MULLION 28mm
STANDARD
W52697

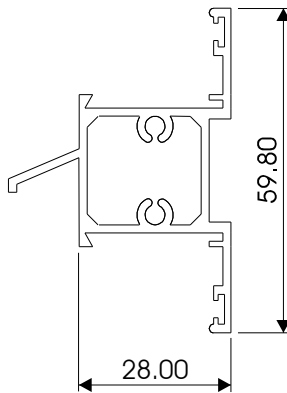

CAS28 MULLION 28mm
WEATHER BAR
W13142

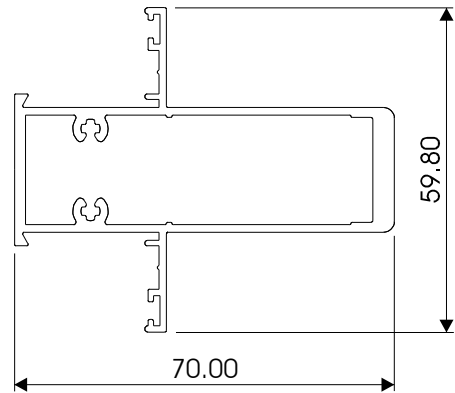

CAS28 MULLION 70mm
W54329

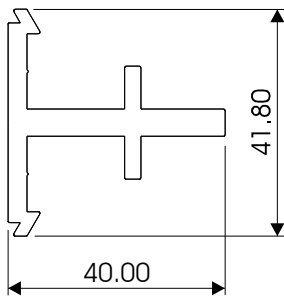

CAS28 COUPLING
MULLION
W52696

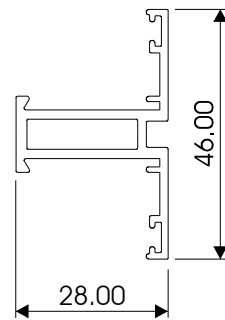

CAS28 MULLION 28mm
COTTAGE PANE
W53283

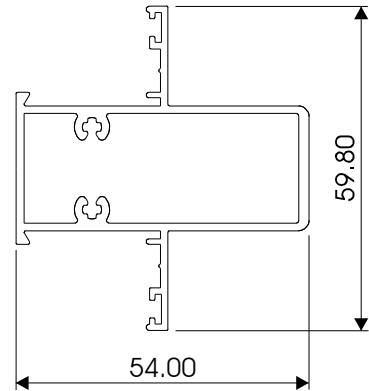

CAS28 MULLION 54mm
W54348

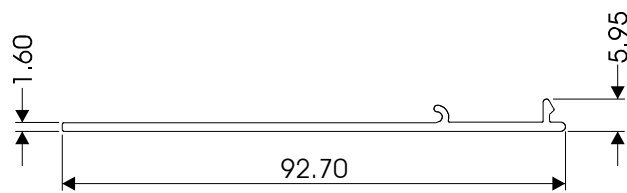

CAS28 FIXING LUG (NEW)
W29499

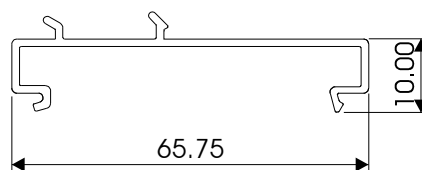

CAS28 ADAPTOR SIDELIGHT
W26780

CASEMENT 28 WINDOW HARDWARE IDENTIFICATION

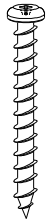

8x30 P/HEAD POSI
S/S SCREW
STPPS830



6x30 P/HEAD POSI
S/S SCREW
STPPS630

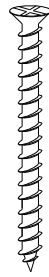

8x40 COUNTERSUNK
POSI S/S SCREW
STCPS840



8x9 C/S
HANDLE SCREW
BLUNT POINT
STPPS895

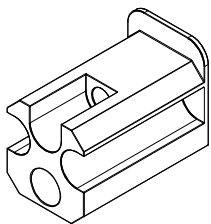

28 CROSS
CONNECTOR PVC
CC28

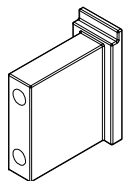

28 COTTAGE PANE
CROSS CONNECTOR 28mm (BLACK)
CPC28

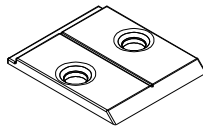

CASEMENT 28
GLAZING BAR
PACKER (RED)
MP28

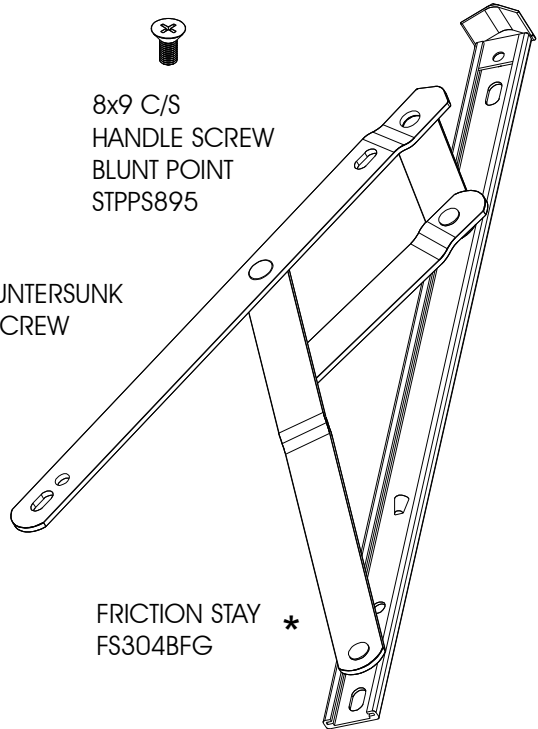

FRICITION STAY
FS304BFG *

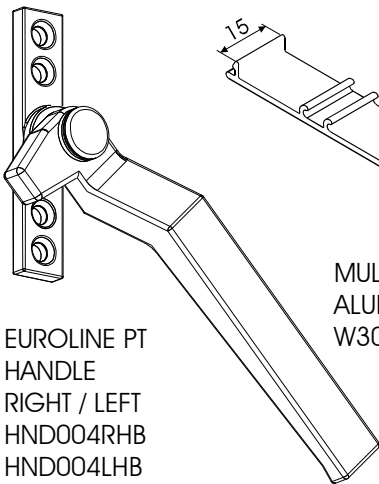

EUROLINE PT
HANDLE
RIGHT / LEFT
HND004RHB
HND004LHB

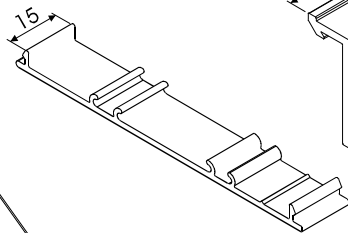

MULTI FIXING LUG
ALUM 15mm
W30607

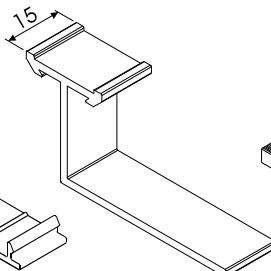

28 FIXING LUG
ALUM 15mm
W13142

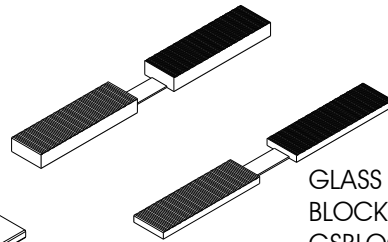

GLASS SETTING
BLOCKS
GSBLOCKS

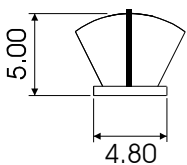

FINPILE
WP48500FG

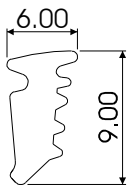

WEDGE H1
VR313FG

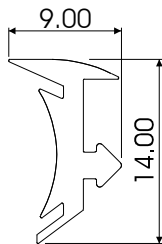

BUTTERFLY H20
VP300FG

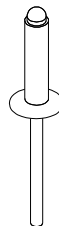

4x10
C/SUNK RIVET
CSKR410



4.8x10
DOME RIVET
DPR4810

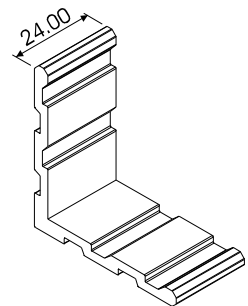

28 CASELITE
CORNER CLEAT
CL52695

*** MAINTENANCE OF STAINLESS STEEL FRICTION STAYS**

To preserve the appearance and prevent corrosion, wipe down Friction Stays with warm water and a mild detergent. For stubborn dirt or stains, use a non corrosive cleaner, for more aggressive stains add a small amount of vinegar to water. Carbon steel brushes and steel wool should be avoided as they may leave particles embedded in the surface which may lead to rusting. After cleaning rinse with hot water and dry using a clean cloth. Cleaning is recommended once a month or more frequently when subjected to regular use or heavy soiling.

CASEMENT 28
 WINDOW
 BUTTERFLY GASKET AND
 WEDGE CODES



BUTTERFLY GASKET

●-B01O

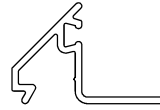

W31137 BEAD



●-W01G

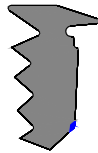

●-W02B

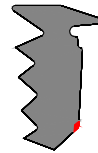

●-W03R



●-W04Y

WEDGES

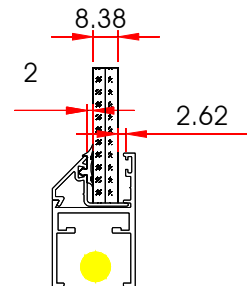
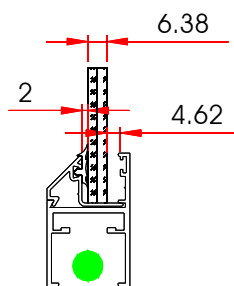
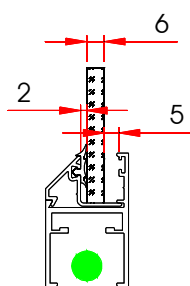
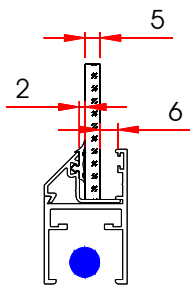
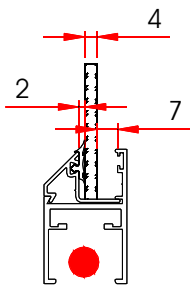

CASEMENT 28 WITH W31137 BEAD

CASEMENT 28
 WINDOW
 SASH LIMITATION CHARTS



		Maximum Vent Width in mm	Maximum Vent Height in mm
Top Hung	W52699	900	600

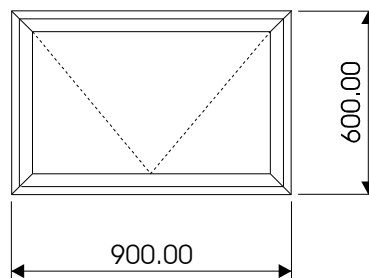

		Maximum Vent Width in mm	Maximum Vent Height in mm
Side Hung	W52699	600	1200

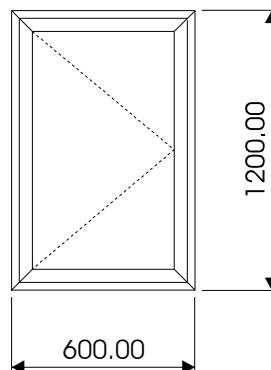

CASEMENT 28
WINDOW
STANDARD TOP HUNG
600Pa WINDLOAD



NOTE: 1. Opening sizes shown in red.
2. Actual window sizes shown in black and brackets.

	600 (590)	900 (890)	1200 (1 190)	1500 (1 490)	1800 (1 790)	2400 (2 390)
600 (590)	28-0606T	28-0906T	28-1206T	28-1506T	28-1806TT	28-2406TT
900 (890)	28-0609T	28-0909T	28-1209T	28-1509T	28-1809TT	28-2409TT
1200 (1 190)	28-0612T	28-0912T	28-1212DT	28-1512DT	28-1812DT	28-2412DT
1500 (1 490)	28-0615DT	28-0915DT	28-1215DT	28-1515DT	28-1815DT	28-2415DT
1800 (1 790)	28-0618DT	28-0918DT	28-1218DT	28-1518DT	28-1818DT	28-2418DT



Econo Mullion
Code: W50957
Inertia Ix: 2.55

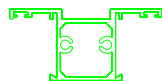

Standard Mullion
Code: W52697
Inertia Ix: 2.62

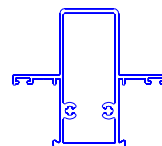

54 mm Mullion
Code: W54348
Inertia Ix: 9.48

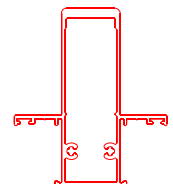

70 mm Mullion
Code: W54329
Inertia Ix: 24.86

SASH LIMITATIONS: Width 900 Max Height 600 Max

Disclaimer: The right to make alterations is reserved
© 2012 Wispeco (Pty) Ltd, All Rights Reserved



CASEMENT 28 WINDOW STANDARD TOP HUNG 1000Pa WINDLOAD



NOTE: 1. Opening sizes shown in red.
2. Actual window sizes shown in black and brackets.

	600 (590)	900 (890)	1200 (1 190)	1500 (1 490)	1800 (1 790)	2400 (2 390)
600 (590)	 28-0606T	 28-0906T	 28-1206T	 28-1506T	 28-1806TT	 28-2406TT
900 (890)	 28-0609T	 28-0909T	 28-1209T	 28-1509T	 28-1809TT	 28-2409TT
1200 (1 190)	 28-0612T	 28-0912T	 28-1212DT	 28-1512DT	 28-1812DT	 28-2412DT
1500 (1 490)	 28-0615DT	 28-0915DT	 28-1215DT	 28-1515DT	 28-1815DT	 28-2415DT
1800 (1 790)	 28-0618DT	 28-0918DT	 28-1218DT	 28-1518DT	 28-1818DT	 28-2418DT



Econo Mullion
Code: W50957
Inertia Ix: 2.55

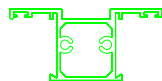

Standard Mullion
Code: W52697
Inertia Ix: 2.62

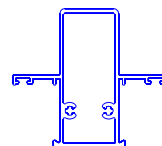

54 mm Mullion
Code: W54348
Inertia Ix: 9.48

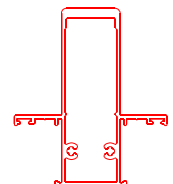

70 mm Mullion
Code: W54329
Inertia Ix: 24.86

SASH LIMITATIONS: Width 900 Max Height 600 Max

Disclaimer: The right to make alterations is reserved
© 2012 Wispeco (Pty) Ltd, All Rights Reserved



CASEMENT 28 WINDOW STANDARD TOP HUNG 1500Pa WINDLOAD



NOTE: 1. Opening sizes shown in red.
2. Actual window sizes shown in black and brackets.

	600 (590)	900 (890)	1200 (1 190)	1500 (1 490)	1800 (1 790)	2400 (2 390)
600 (590)	 28-0606T	 28-0906T	 28-1206T	 28-1506T	 28-1806TT	 28-2406TT
900 (890)	 28-0609T	 28-0909T	 28-1209T	 28-1509T	 28-1809TT	 28-2409TT
1200 (1 190)	 28-0612T	 28-0912T	 28-1212DT	 28-1512DT	 28-1812DT	 28-2412DT
1500 (1 490)	 28-0615DT	 28-0915DT	 28-1215DT	 28-1515DT	 28-1815DT	 28-2415DT
1800 (1 790)	 28-0618DT	 28-0918DT	 28-1218DT	 28-1518DT	 28-1818DT	



Econo Mullion
Code: W50957
Inertia Ix: 2.55

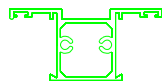

Standard Mullion
Code: W52697
Inertia Ix: 2.62

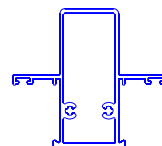

54 mm Mullion
Code: W54348
Inertia Ix: 9.48

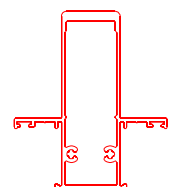

70 mm Mullion
Code: W54329
Inertia Ix: 24.86

SASH LIMITATIONS: Width 900 Max Height 600 Max

Disclaimer: The right to make alterations is reserved
© 2012 Wispeco (Pty) Ltd, All Rights Reserved



CASEMENT 28 WINDOW STANDARD SIDE HUNG 600Pa WINDLOAD



NOTE: 1. Opening sizes shown in red.
2. Actual window sizes shown in black and brackets.

	600 (590)	900 (890)	1200 (1 190)	1500 (1 490)	1800 (1 790)	2400 (2 390)
600 (590)						
900 (890)	 28-0609S	 28-0909S	 28-1209S	 28-1509S	 28-1809SS	 28-2409SS
1200 (1 190)	 28-0612S	 28-0912S	 28-1212S	 28-1512S	 28-1812SS	 28-2412SS
1500 (1 490)	 28-0615S	 28-0915S	 28-1215S	 28-1515S	 28-1815SS	 28-2415SS
1800 (1 790)	 28-0618S	 28-0918S	 28-1218S	 28-1518S	 28-1818SS	 28-2418SS



Econo Mullion
Code: W50957
Inertia Ix: 2.55

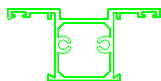

Standard Mullion
Code: W52697
Inertia Ix: 2.62

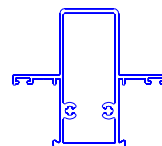

54 mm Mullion
Code: W54348
Inertia Ix: 9.48

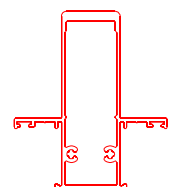

70 mm Mullion
Code: W54329
Inertia Ix: 24.86

SASH LIMITATIONS: Width 600 Max Height 1200 Max

Disclaimer: The right to make alterations is reserved
© 2012 Wispeco (Pty) Ltd, All Rights Reserved



CASEMENT 28 WINDOW STANDARD SIDE HUNG 1000Pa WINDLOAD



NOTE: 1. Opening sizes shown in red.
2. Actual window sizes shown in black and brackets.

	600 (590)	900 (890)	1200 (1 190)	1500 (1 490)	1800 (1 790)	2400 (2 390)
600 (590)						
900 (890)	 28-0609S	 28-0909S	 28-1209S	 28-1509S	 28-1809SS	 28-2409SS
1200 (1 190)	 28-0612S	 28-0912S	 28-1212S	 28-1512S	 28-1812SS	 28-2412SS
1500 (1 490)	 28-0615S	 28-0915S	 28-1215S	 28-1515S	 28-1815SS	 28-2415SS
1800 (1 790)	 28-0618S	 28-0918S	 28-1218S	 28-1518S	 28-1818SS	 28-2418SS



Econo Mullion
Code: W50957
Inertia Ix: 2.55

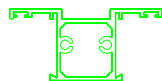

Standard Mullion
Code: W52697
Inertia Ix: 2.62

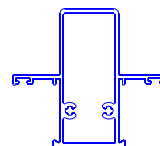

54 mm Mullion
Code: W54348
Inertia Ix: 9.48

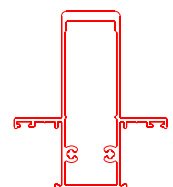

70 mm Mullion
Code: W54329
Inertia Ix: 24.86

SASH LIMITATIONS: Width 600 Max Height 1200 Max

Disclaimer: The right to make alterations is reserved
© 2012 Wispeco (Pty) Ltd, All Rights Reserved



CASEMENT 28 WINDOW STANDARD SIDE HUNG 1500Pa WINDLOAD



NOTE: 1. Opening sizes shown in red.
2. Actual window sizes shown in black and brackets.

	600 (590)	900 (890)	1200 (1 190)	1500 (1 490)	1800 (1 790)	2400 (2 390)
600 (590)						
900 (890)	 28-0609S	 28-0909S	 28-1209S	 28-1509S	 28-1809SS	 28-2409SS
1200 (1 190)	 28-0612S	 28-0912S	 28-1212S	 28-1512S	 28-1812SS	 28-2412SS
1500 (1 490)	 28-0615S	 28-0915S	 28-1215S	 28-1515S	 28-1815SS	 28-2415SS
1800 (1 790)	 28-0618S	 28-0918S	 28-1218S	 28-1518S	 28-1818SS	 28-2418SS



Econo Mullion
Code: W50957
Inertia Ix: 2.55

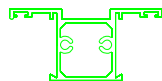

Standard Mullion
Code: W52697
Inertia Ix: 2.62

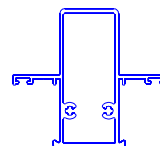

54 mm Mullion
Code: W54348
Inertia Ix: 9.48

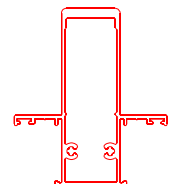

70 mm Mullion
Code: W54329
Inertia Ix: 24.86

SASH LIMITATIONS: Width 600 Max Height 1200 Max

Disclaimer: The right to make alterations is reserved
© 2012 Wispeco (Pty) Ltd, All Rights Reserved



CASEMENT 28
WINDOW
STANDARD TOP HUNG WINDOW
TYPICAL CONFIGURATIONS

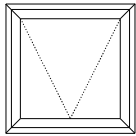

A
SINGLE TOP HUNG

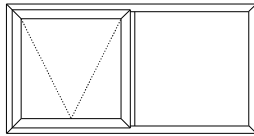

BB
TOP HUNG
NEXT TO FIXED

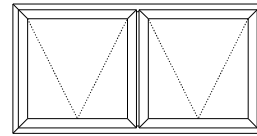

CC
TOP HUNG NEXT
TO TOP HUNG

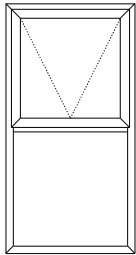

B
TOP HUNG
OVER FIXED

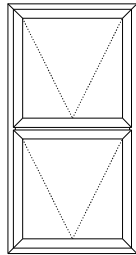

C
TOP HUNG
OVER TOP HUNG

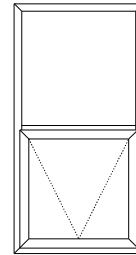

E
FIXED OVER
TOP HUNG

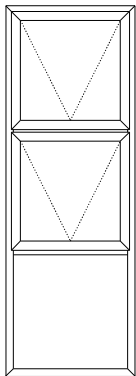

D
DOUBLE TOP HUNG
OVER FIXED

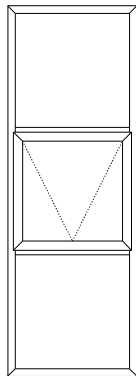

DD
FIXED OVER
TOP HUNG
OVER FIXED

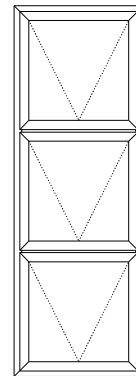

EE
TRIPLE TOP HUNG

CASEMENT 28
WINDOW
STANDARD SIDE HUNG WINDOW
TYPICAL CONFIGURATIONS

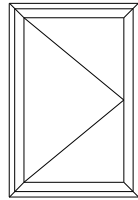

A
SINGLE SIDE HUNG

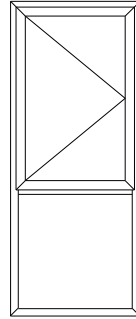

B
SIDE HUNG
OVER FIXED

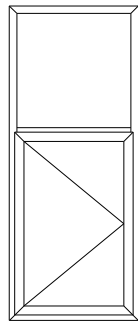

C
FIXED OVER
SIDE HUNG

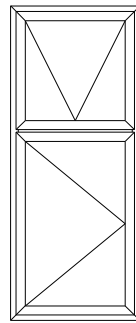

D
TOP HUNG
OVER SIDE HUNG

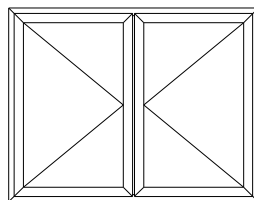

CC
SIDE HUNG NEXT
TO SIDE HUNG

CASEMENT 28
WINDOW
COTTAGE PANE WINDOW FIXED
PANEL TYPICAL CONFIGURATIONS

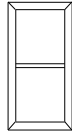

A

1 x 2 FIXED PANEL

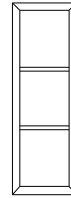

B

1 x 3 FIXED PANEL

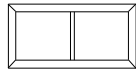

C

2 x 1 FIXED PANEL

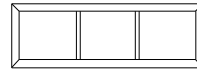

D

3 x 1 FIXED PANEL

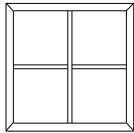

E

2 x 2 FIXED PANEL

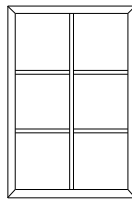

F

2 x 3 FIXED PANEL

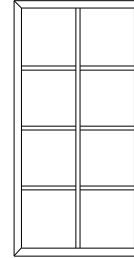

G

2 x 4 FIXED PANEL

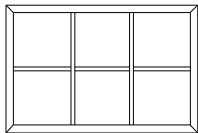

H

3 x 2 FIXED PANEL

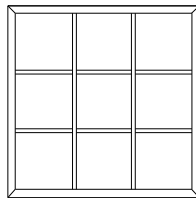

I

3 x 3 FIXED PANEL

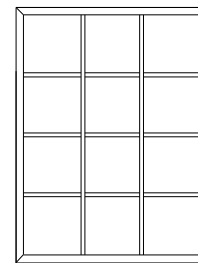

J

3 x 4 FIXED PANEL

CASEMENT 28
WINDOW
COTTAGE PANE WINDOW
TOP HUNG & SIDE HUNG
TYPICAL CONFIGURATIONS



TOP HUNG

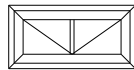

P

2 x 1 PANE
SINGLE TOP HUNG

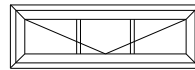

R

3 x 1 PANE
SINGLE TOP HUNG

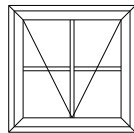

Q

2 x 2 PANE
SINGLE TOP HUNG

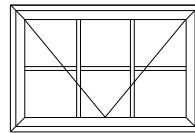

S

3 x 2 PANE
SINGLE TOP HUNG

SIDE HUNG

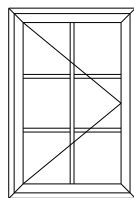

P

2 x 3 PANE
SINGLE SIDE HUNG

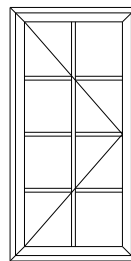

Q

2 x 4 PANE
SINGLE SIDE HUNG

CASEMENT 28 WINDOW TYPICAL COUPLING CONFIGURATIONS



MULLION COUPLING DETAIL
UNEQUAL LEG OUTER FRAME &
COUPLING MULLION
(W52696 + W52694)

MAXIMUM HEIGHT: 1500mm

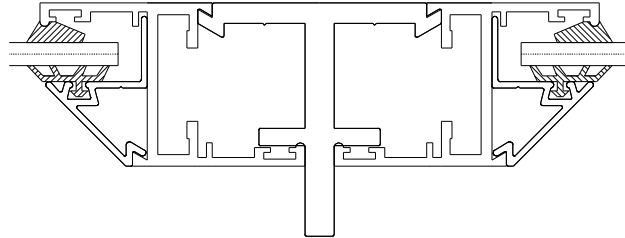

MULLION COUPLING DETAIL
EQUAL LEG OUTER FRAME &
SMALL T COUPLING MULLION
(W11019 + W52692)

MAXIMUM HEIGHT: 1500mm

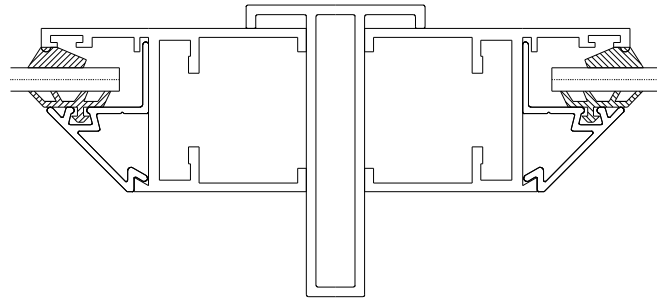

MULLION COUPLING DETAIL
TUBULAR EQUAL LEG OUTER
FRAME & SMALL T COUPLING
MULLION (W11019 + W50958)

MAXIMUM HEIGHT: 1500mm

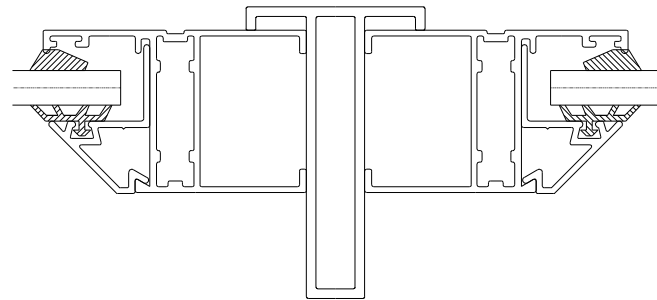

MULLION COUPLING DETAIL
54mm OUTER FRAME &
COUPLING MULLION
(W24497 + W52007)

MAXIMUM HEIGHT: 1500mm

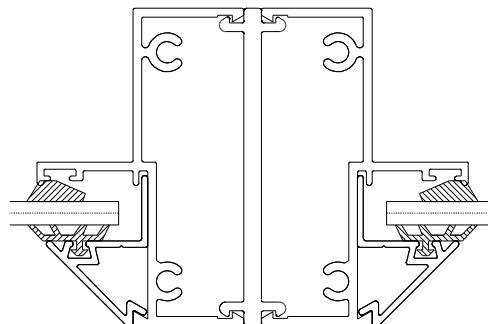

CASEMENT 28 WINDOW FASTENING POSITIONS

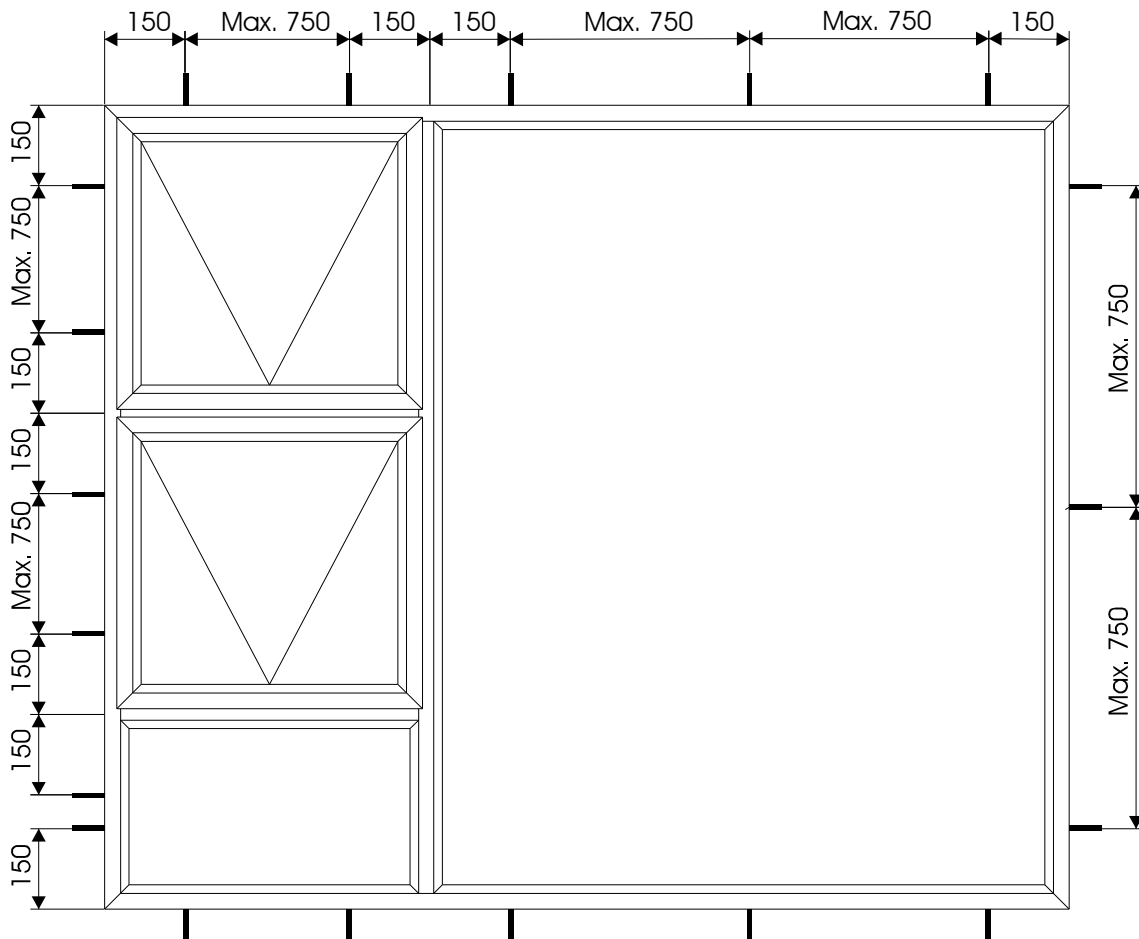
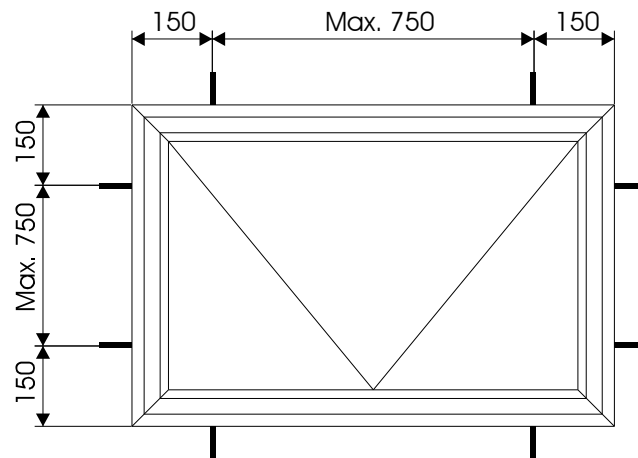

General:

The window is fixed into position - the sill is then built at a later stage - the bottom lugs can be left in place but it is often found that most times the mason either bends them out of its way or breaks them off. This practically means that most windows are only secured on 3 sides.

CASEMENT 28
 WINDOW
 TYPICAL CROSS SECTIONAL DETAIL
 DOUBLE TOP HUNG OVER FIXED

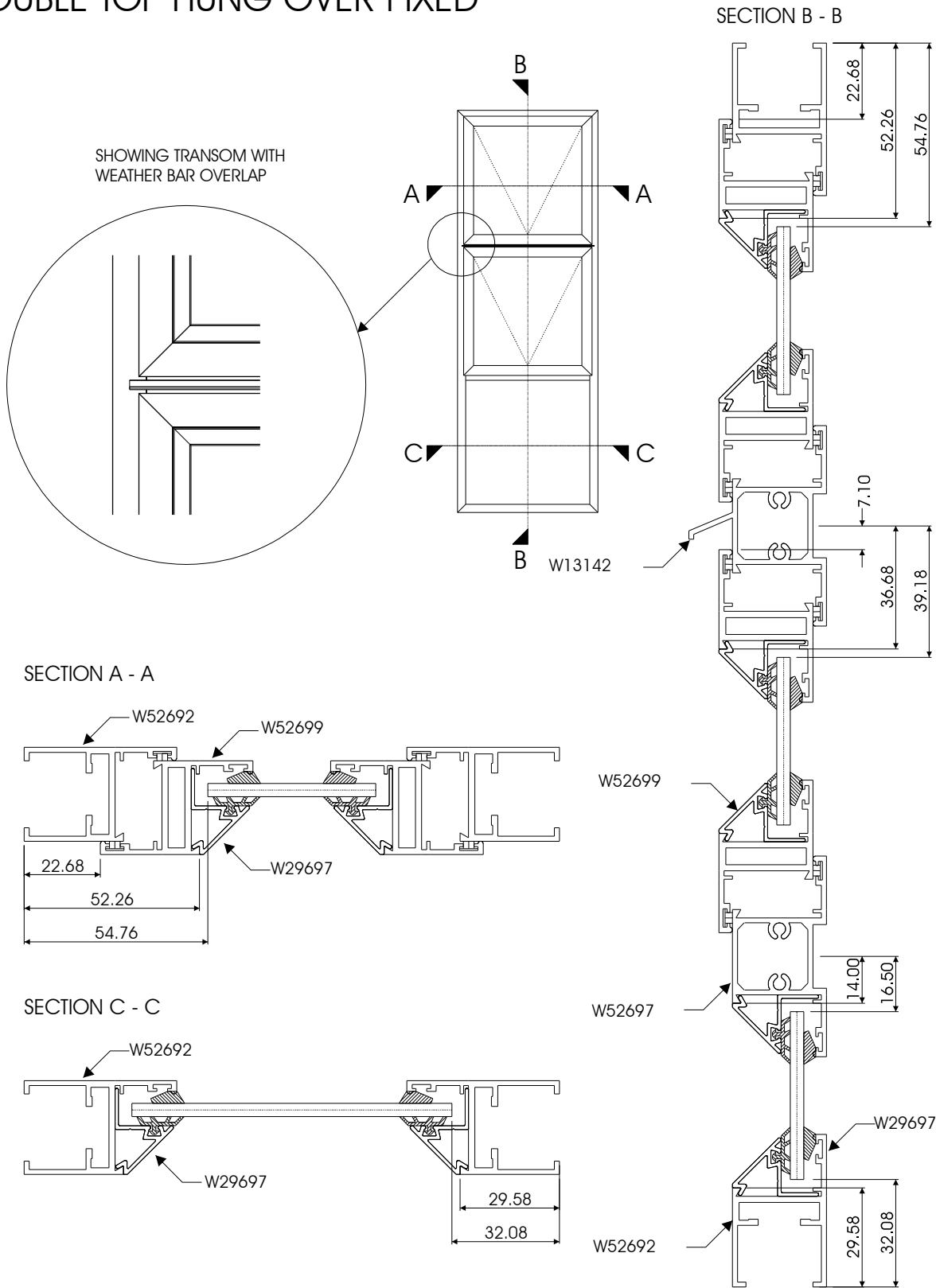

CASEMENT 28
 WINDOW
 TYPICAL CROSS SECTIONAL DETAIL
 SIDE HUNG OVER FIXED

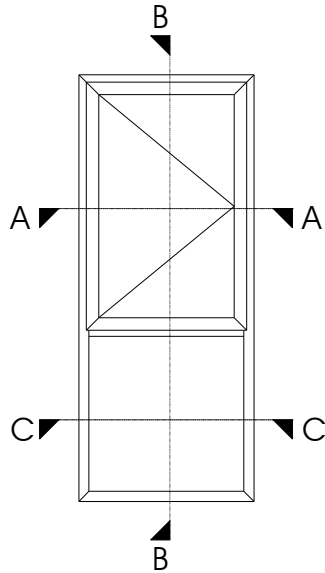

SECTION B - B

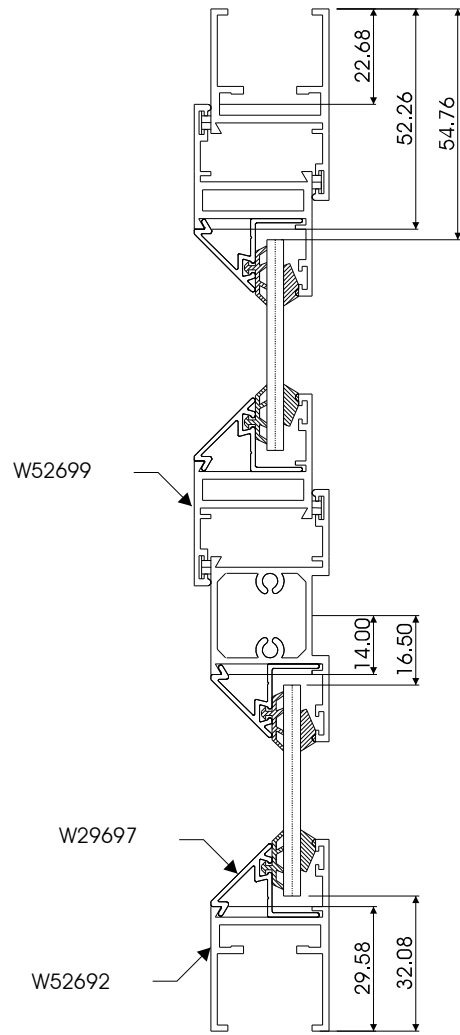

SECTION A - A

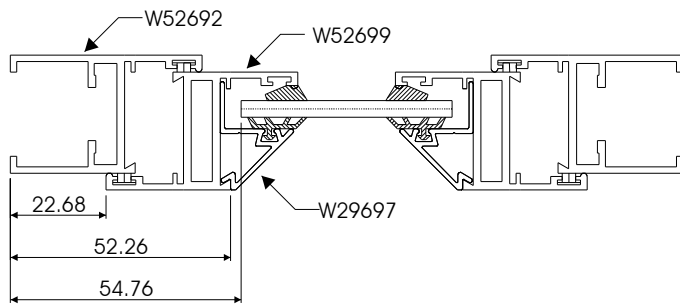

SECTION C - C

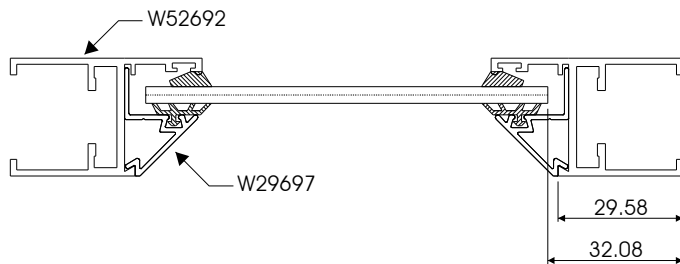

CASEMENT 28
 WINDOW
 COTTAGE PANE TYPICAL
 CROSS SECTIONAL DETAIL
 2 x 2 TOP HUNG OVER
 2 x 1 FIXED PANEL

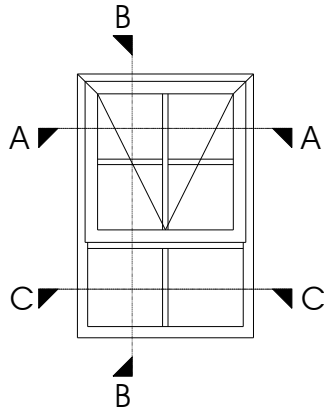

SECTION B - B

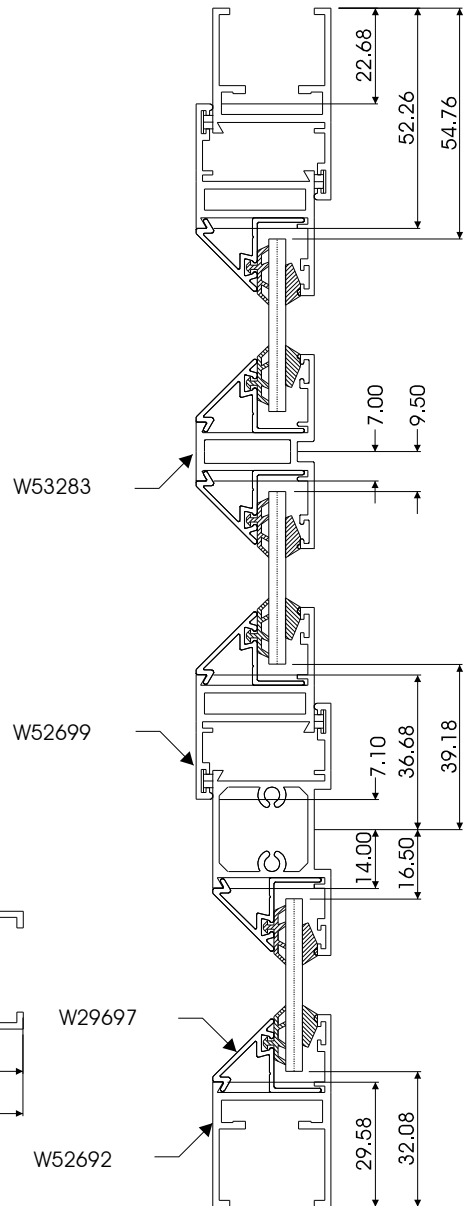

SECTION C - C

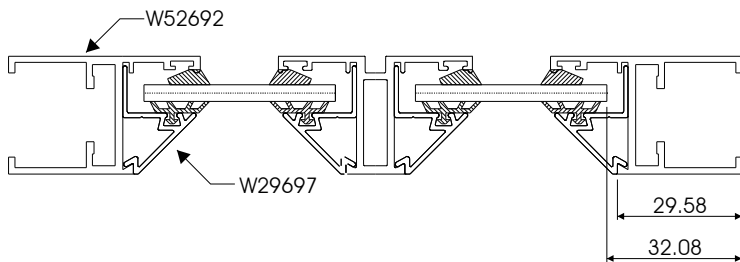

SECTION A - A

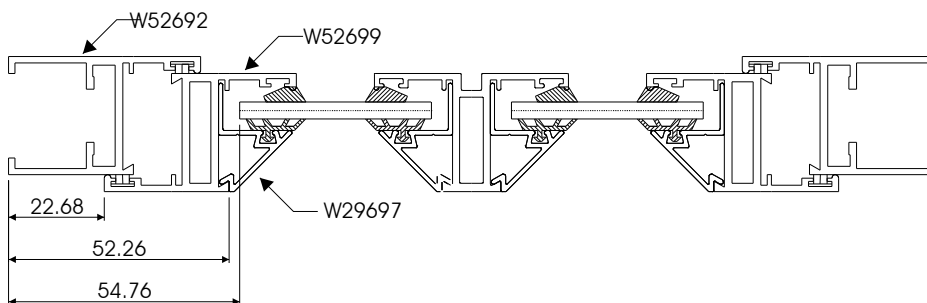

CASEMENT 28
 WINDOW
 LITE TYPICAL CROSS SECTIONAL DETAIL
 SIDE OVER FIXED

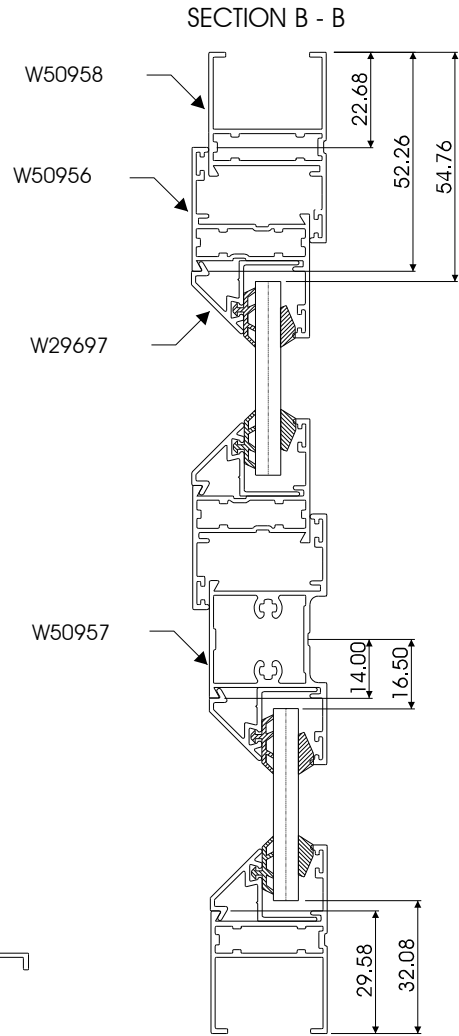
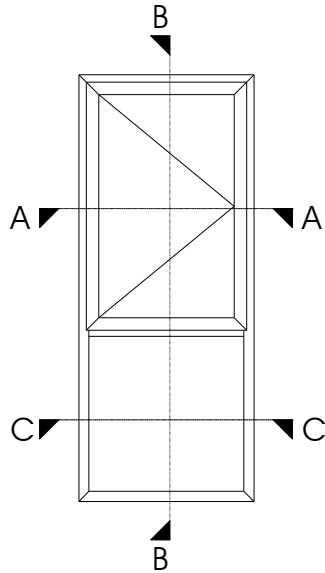

SECTION A - A

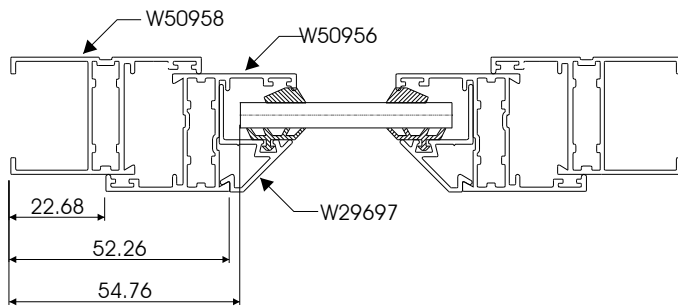

SECTION C - C

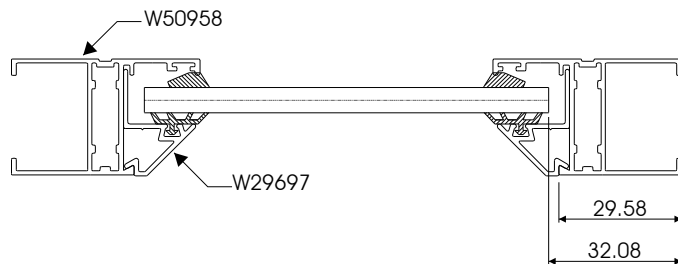

CASEMENT 28 WINDOW OUTER FRAME COMPONENT ASSEMBLY DETAIL

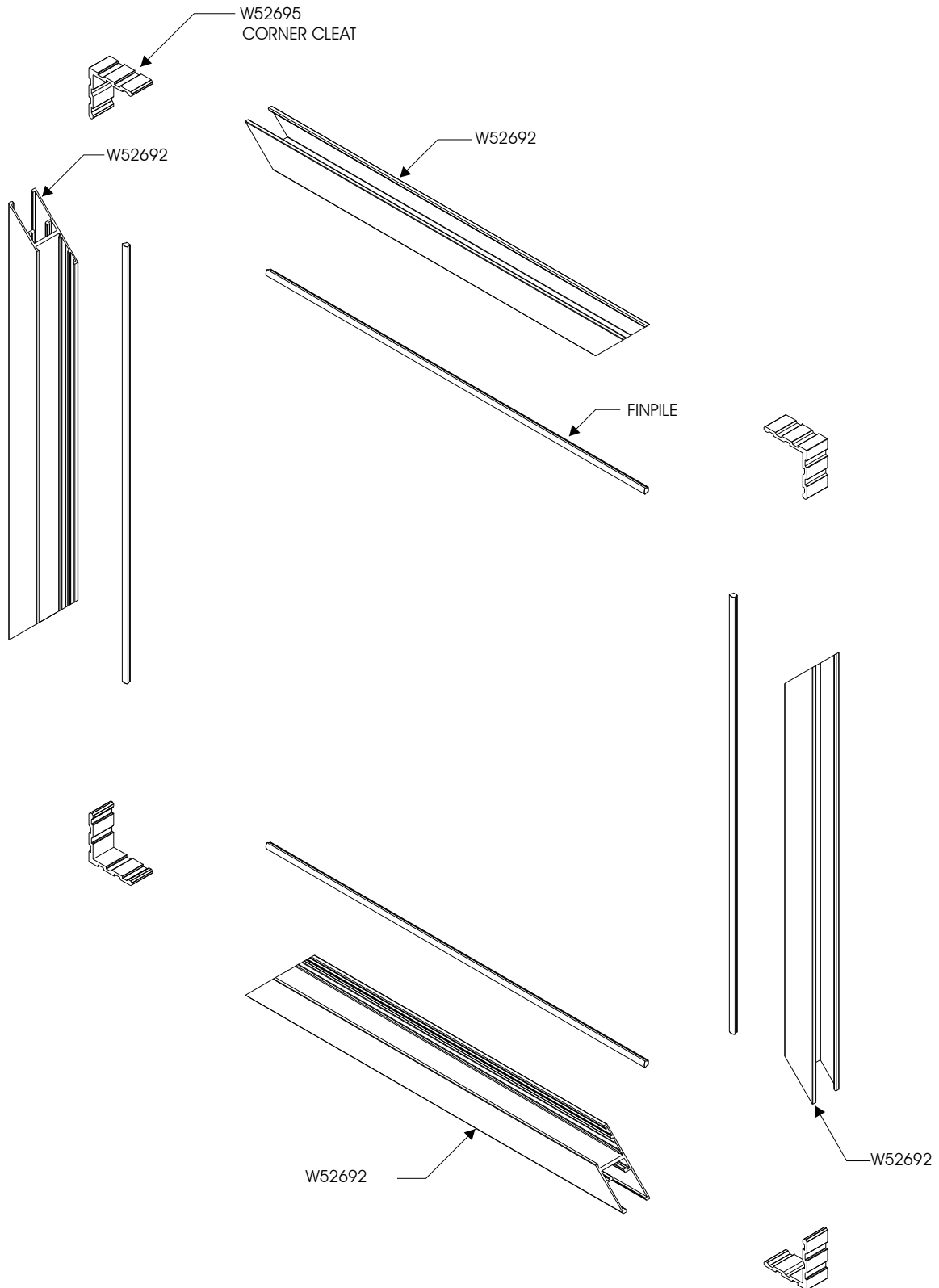

CASEMENT 28
WINDOW
SASH FRAME COMPONENT
ASSEMBLY DETAIL

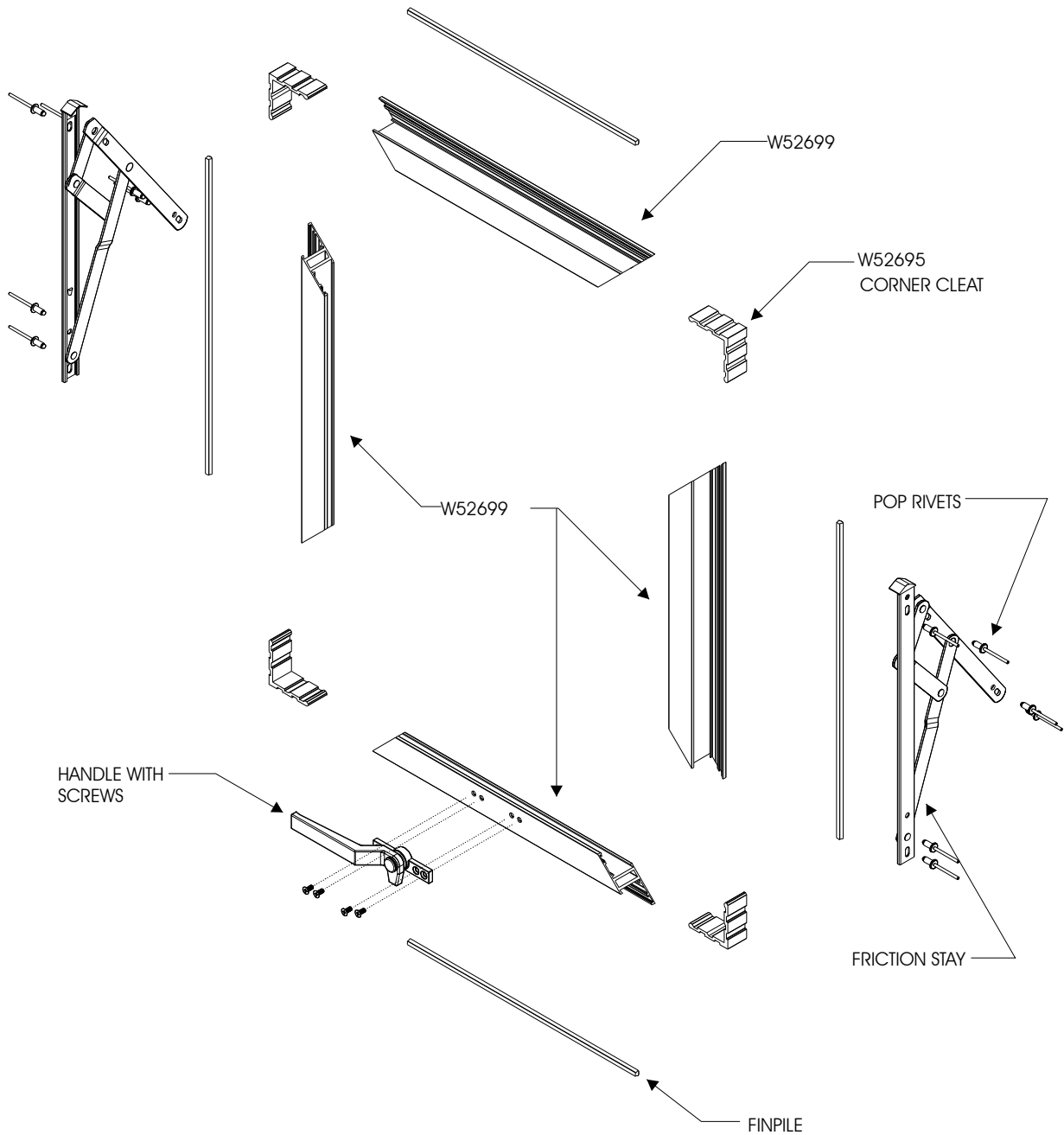

CASEMENT 28
WINDOW
EQUAL LEG OUTER FRAME
SILL LEVEL & MACHINING DETAIL

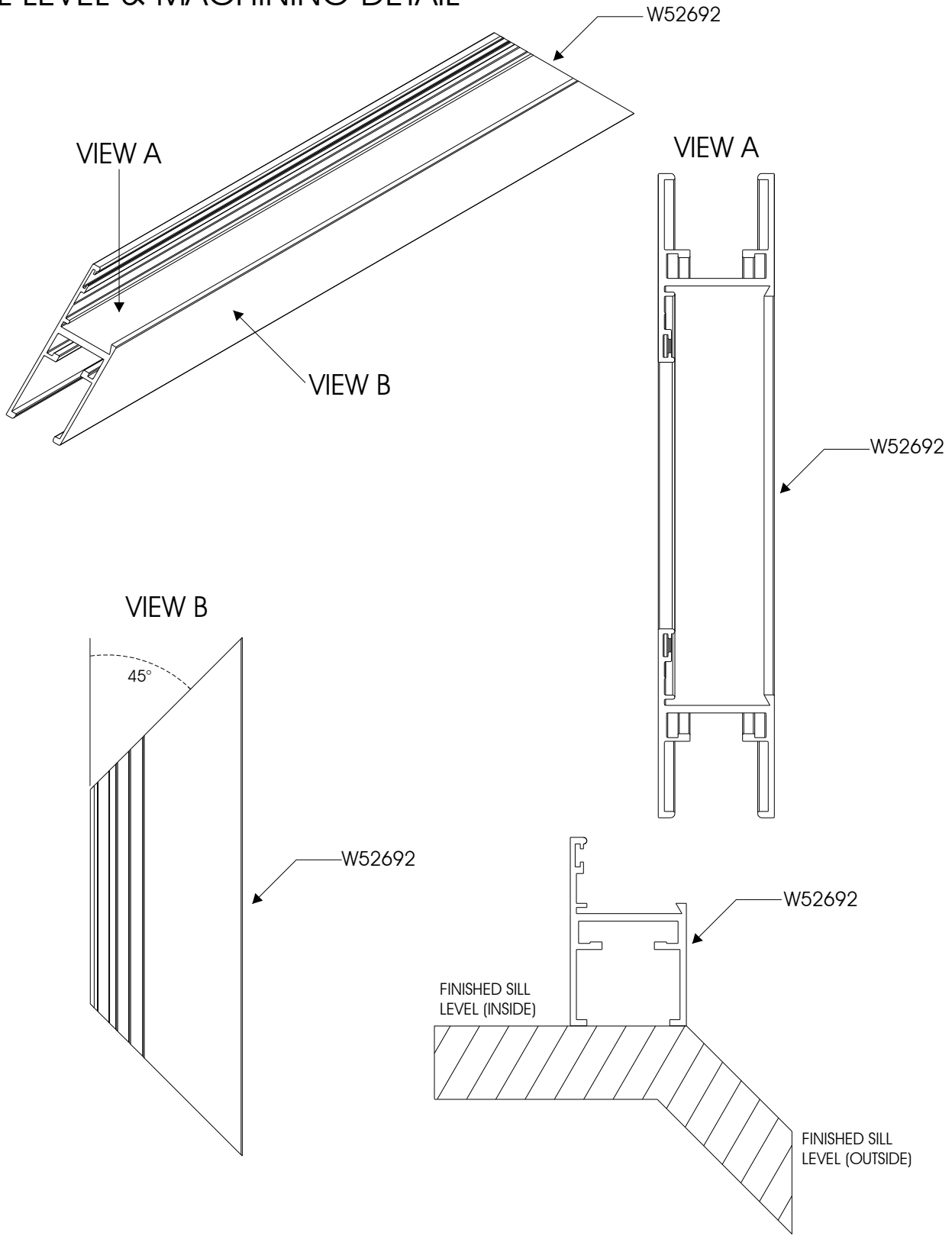

CASEMENT 28
 WINDOW
 UNEQUAL LEG OUTER FRAME
 SILL LEVEL & MACHINING DETAIL

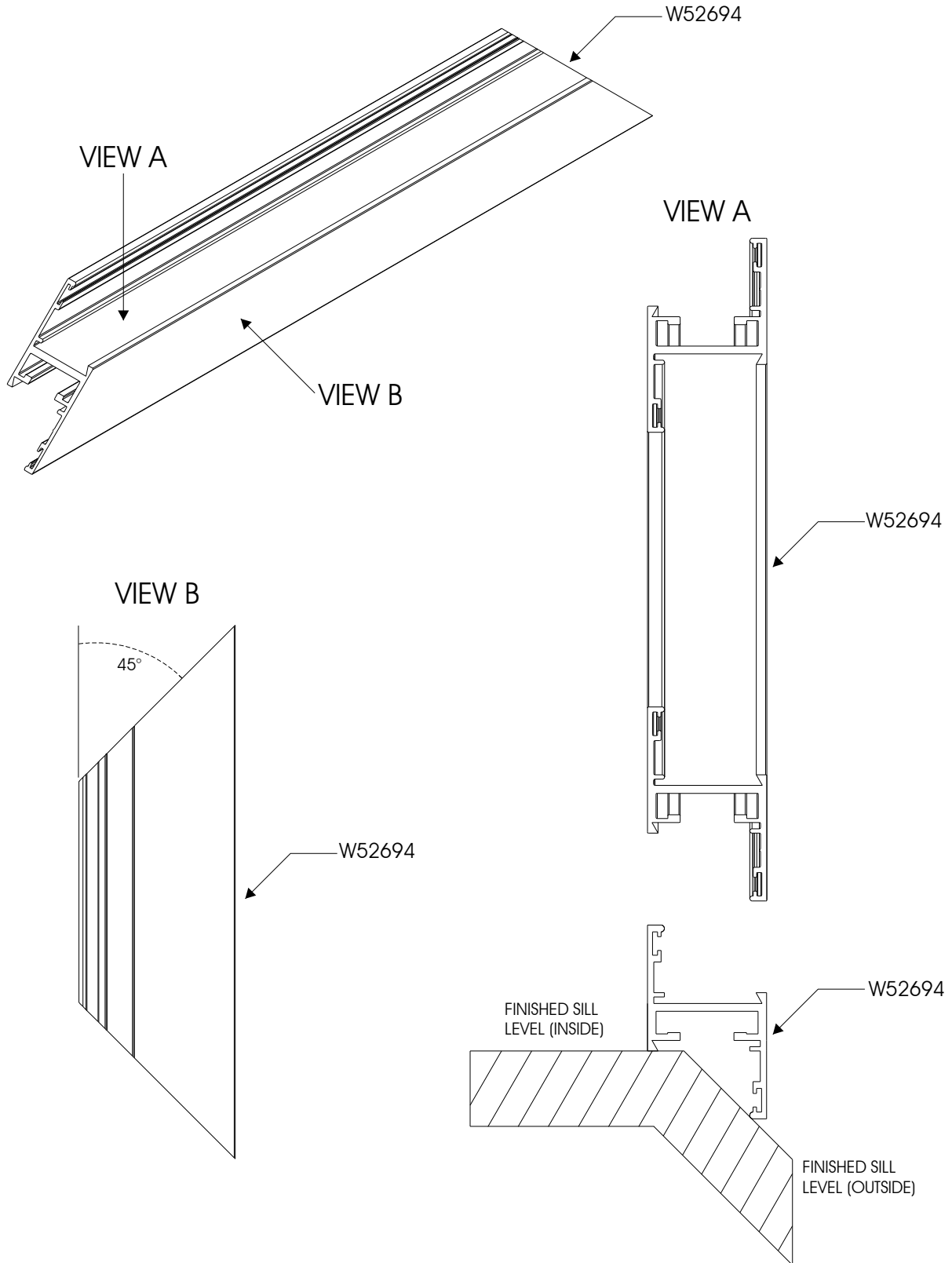

CASEMENT 28
 WINDOW
 54mm OUTER FRAME
 SILL LEVEL & MACHINING DETAIL

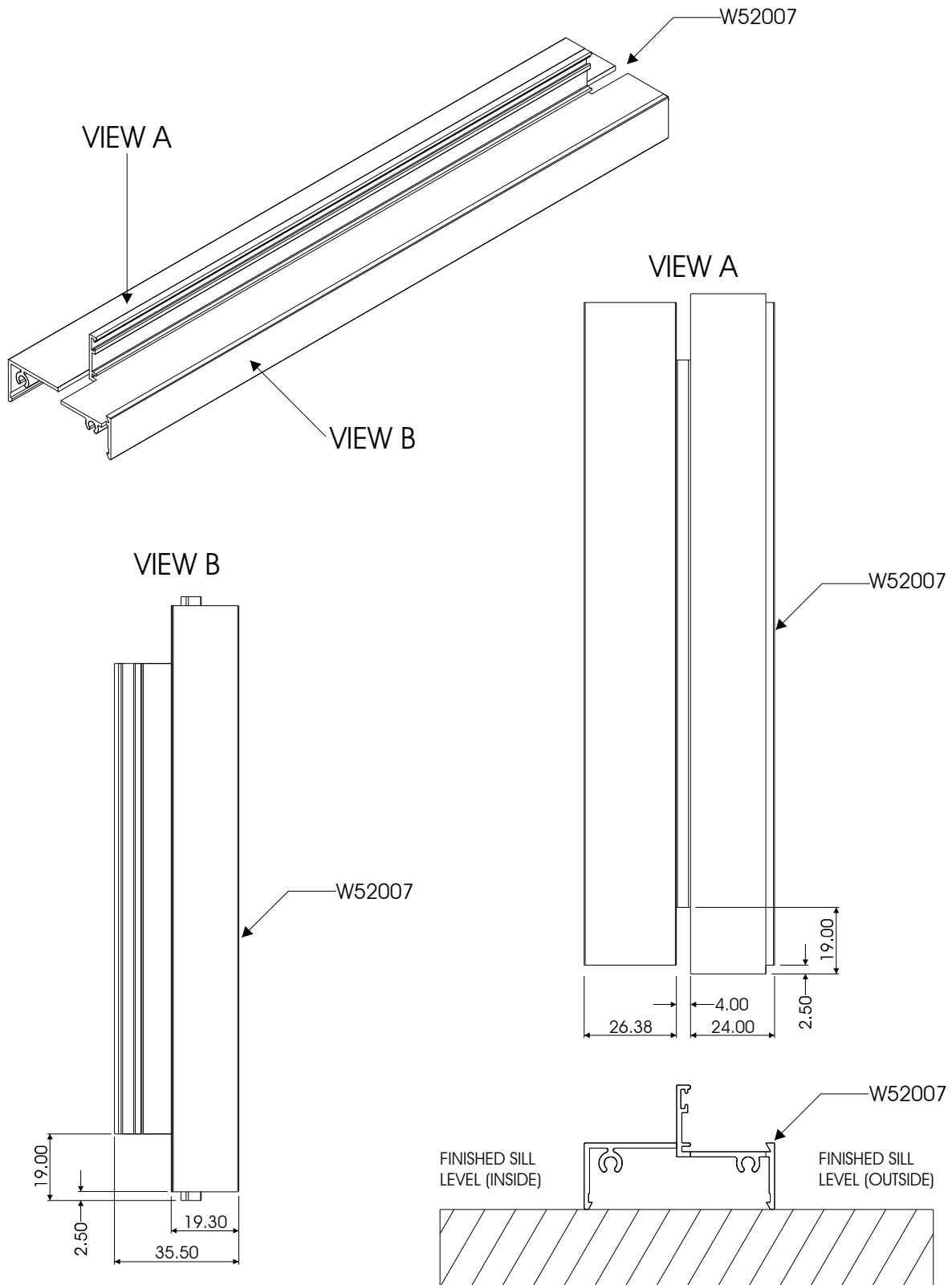

CASEMENT 28
 WINDOW
 70mm OUTER FRAME
 SILL LEVEL & MACHINING DETAIL

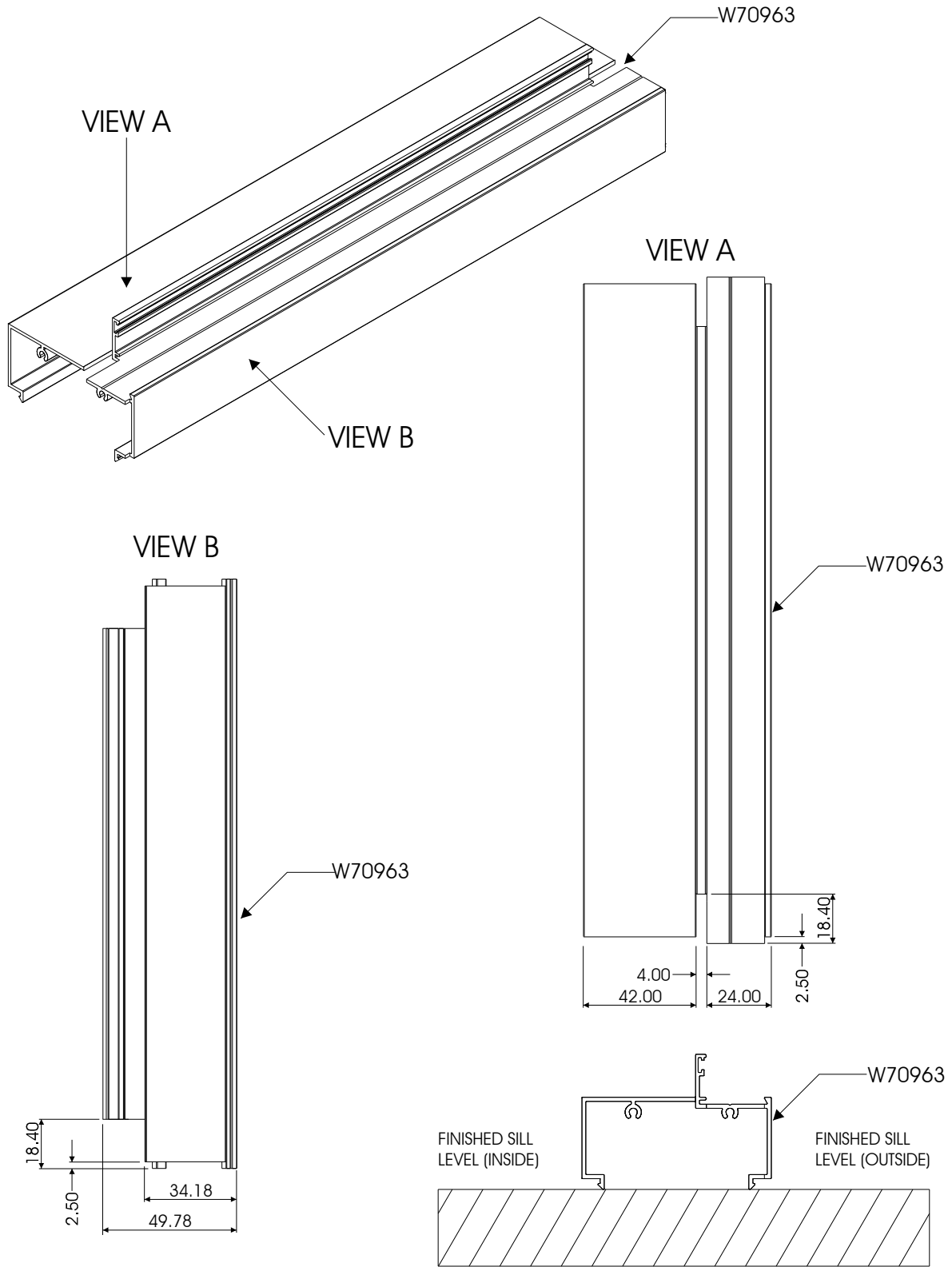

CASEMENT 28
WINDOW
TUBULAR EQUAL LEG OUTER FRAME
SILL LEVEL & MACHINING DETAIL

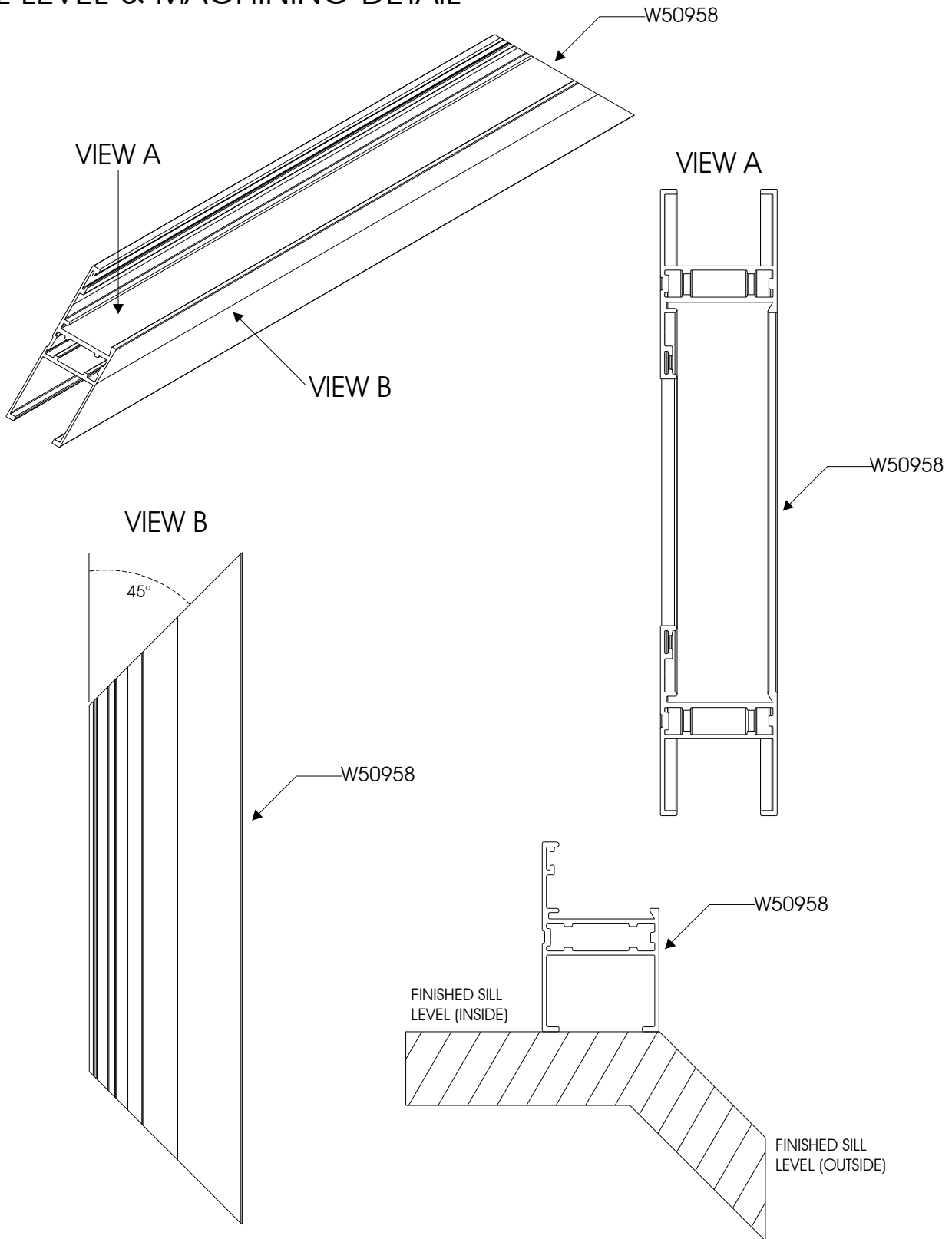

CASEMENT 28
 WINDOW
 STANDARD MULLION
 MACHINING DETAIL FOR END MILLING
 ON EQUAL LEG OUTER FRAME

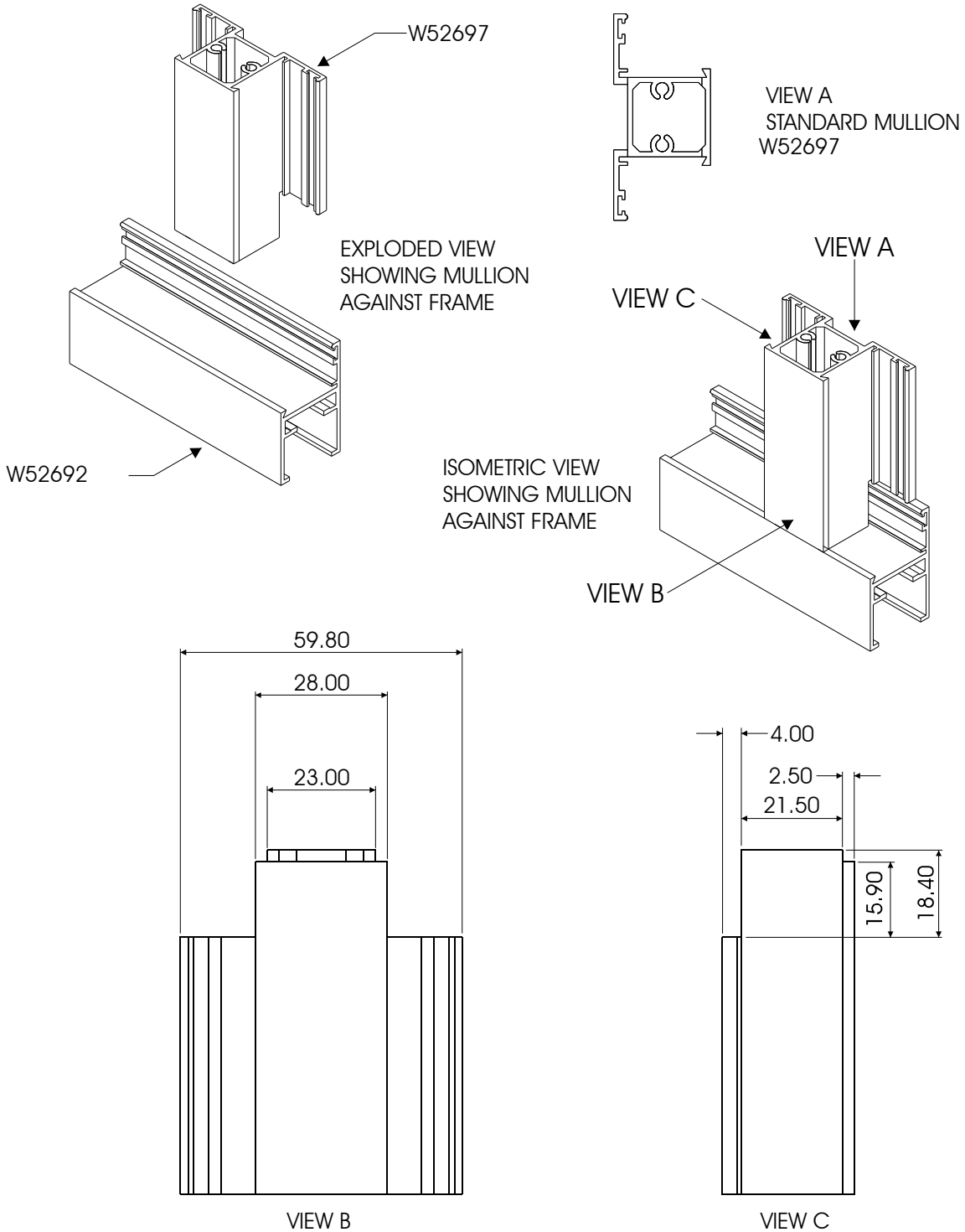

CASEMENT 28
 WINDOW
 STANDARD MULLION
 MACHINING DETAIL FOR END MILLING
 ON UNEQUAL LEG OUTER FRAME

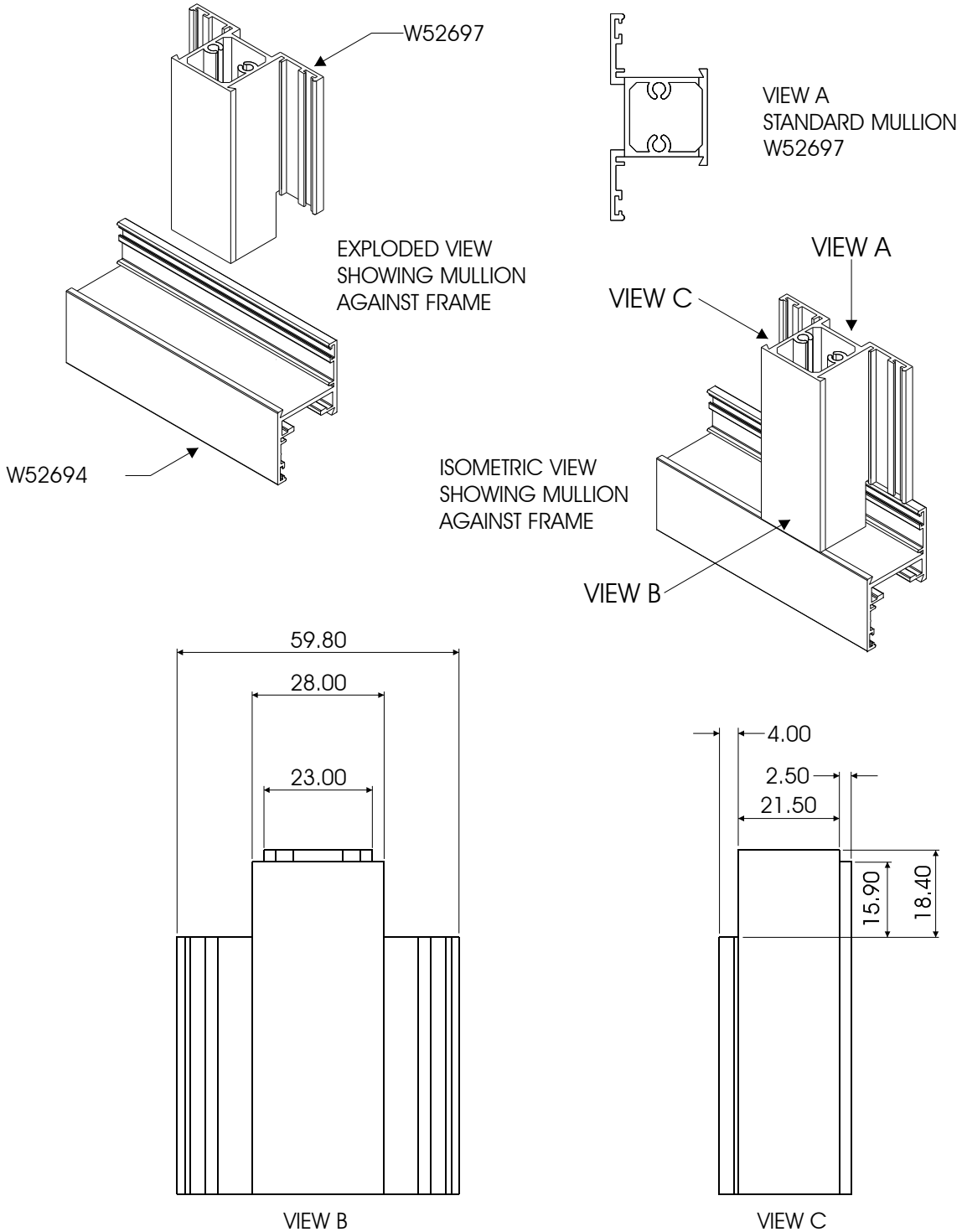

CASEMENT 28
 WINDOW
 STANDARD MULLION
 MACHINING DETAIL FOR END MILLING
 ON 54mm OUTER FRAME

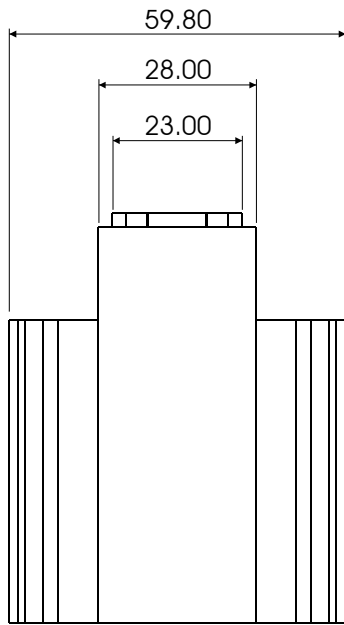
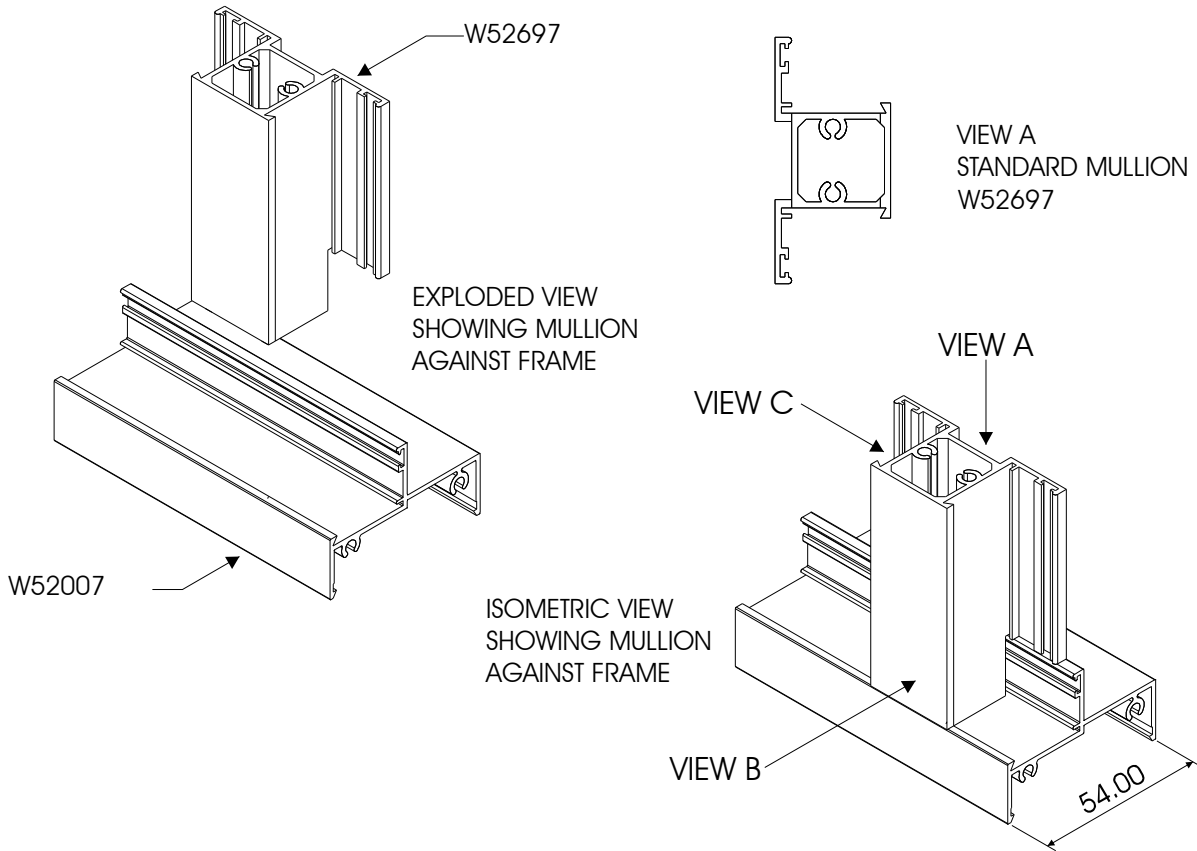

VIEW B

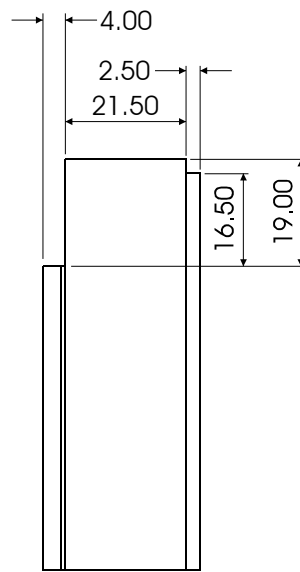

VIEW C

CASEMENT 28
 WINDOW
 STANDARD MULLION
 MACHINING DETAIL FOR END MILLING
 ON 70mm OUTER FRAME

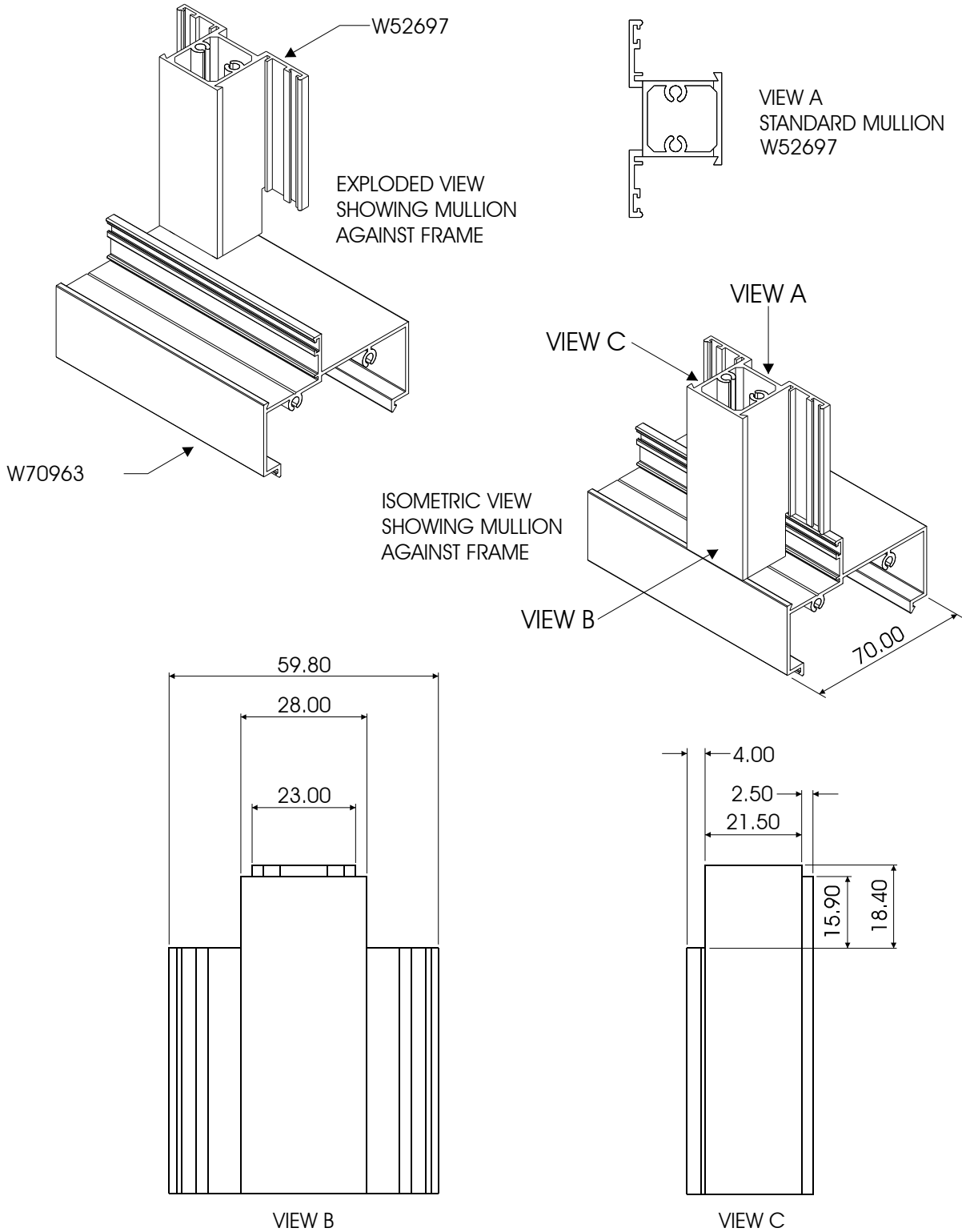

CASEMENT 28
 WINDOW
 STANDARD MULLION
 MACHINING DETAIL FOR END MILLING
 ON TUBULAR EQUAL LEG OUTER FRAME

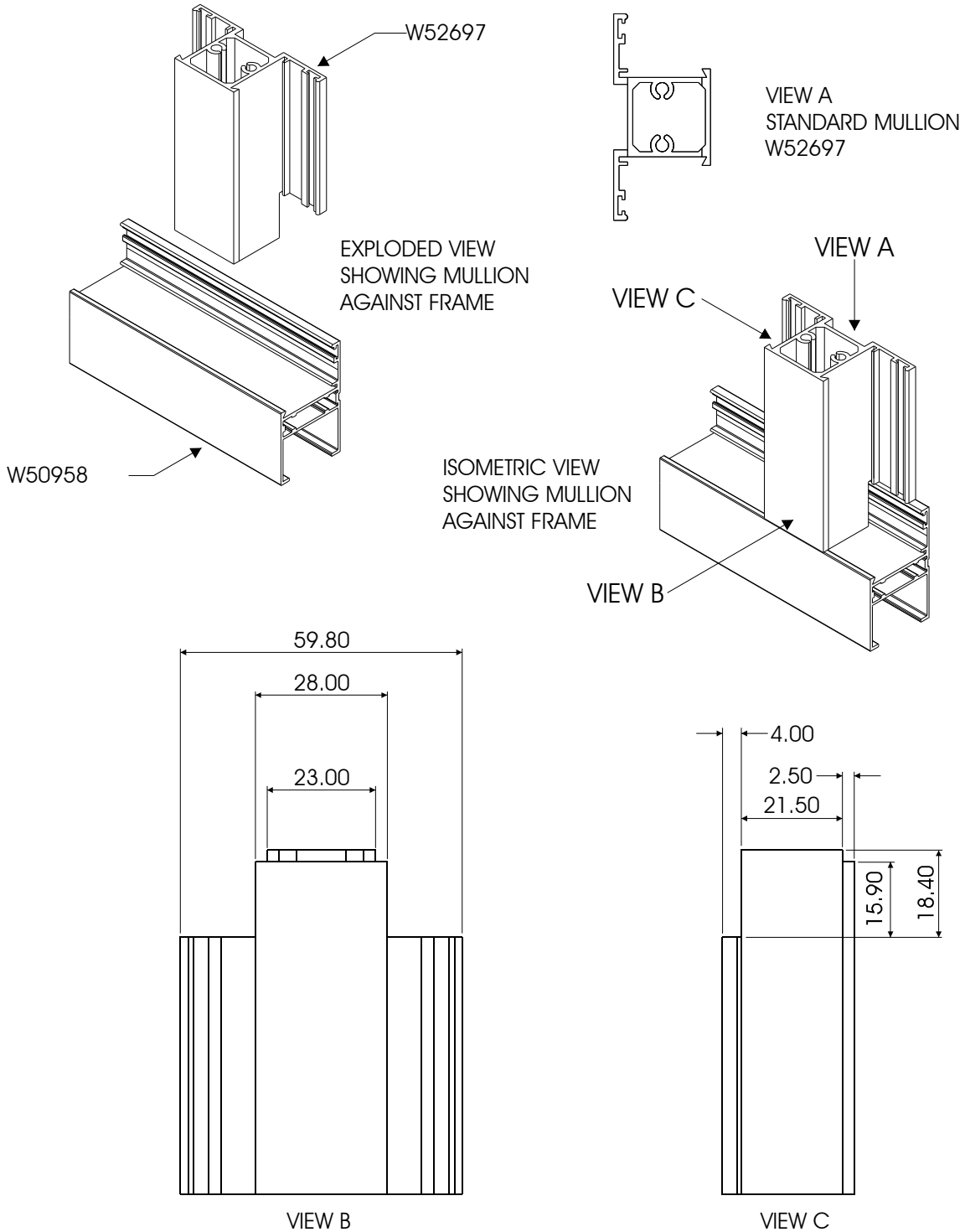

CASEMENT 28
 WINDOW
 TRANSOM WITH W/BAR
 MACHINING DETAIL FOR END MILLING
 ON EQUAL LEG OUTER FRAME

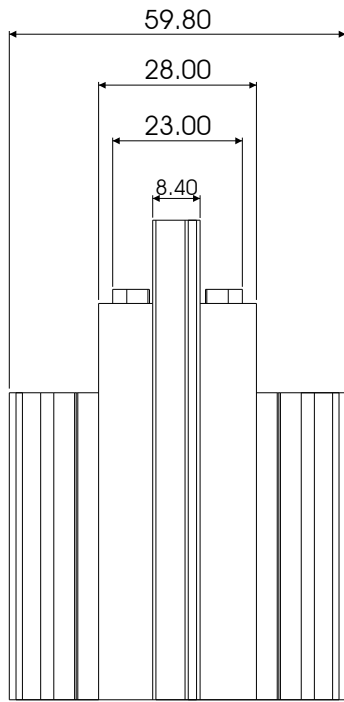
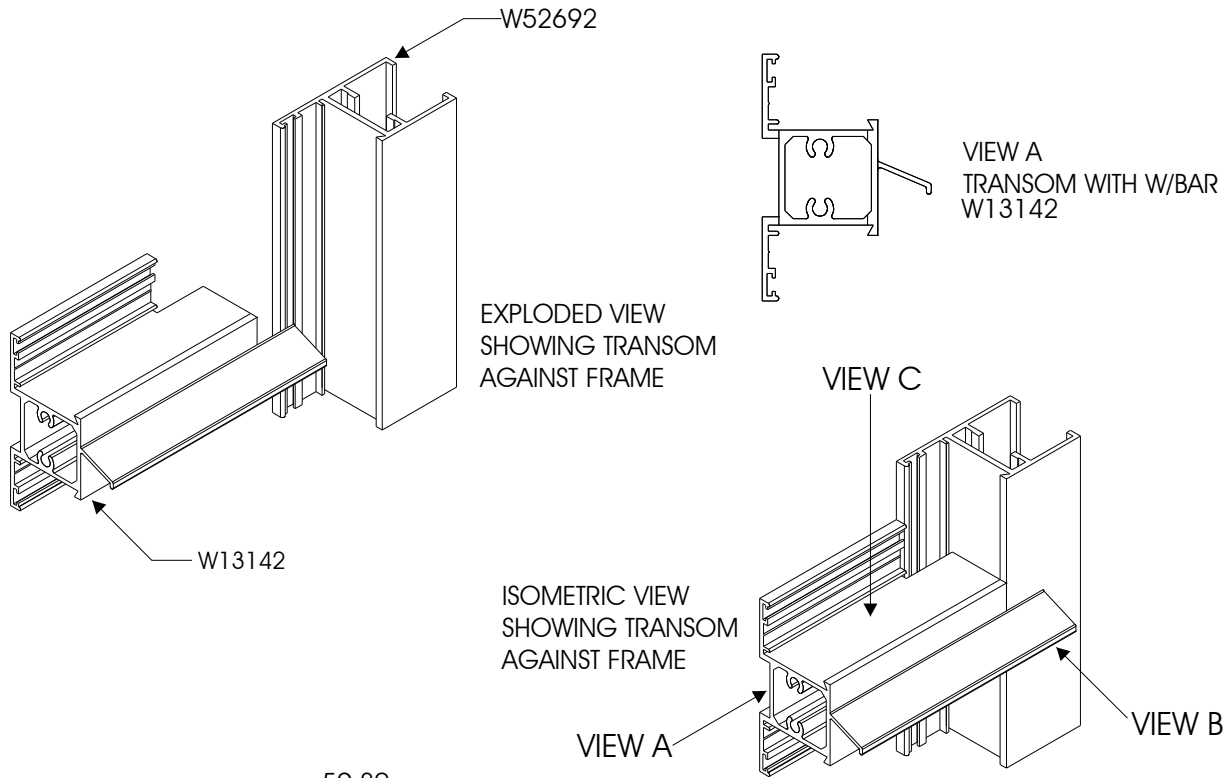

VIEW B

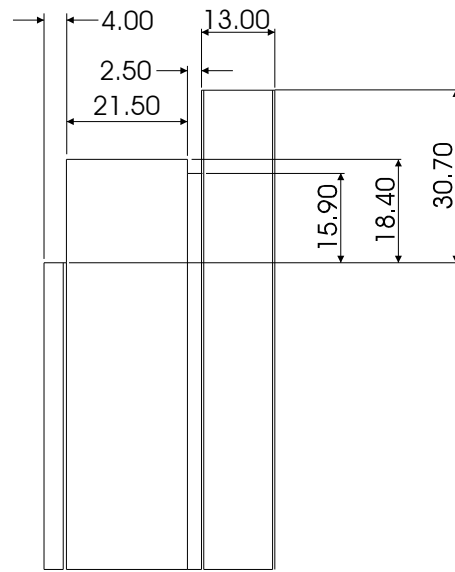

VIEW C

CASEMENT 28
 WINDOW
 TRANSOM WITH W/BAR
 MACHINING DETAIL FOR END MILLING
 ON UNEQUAL LEG OUTER FRAME

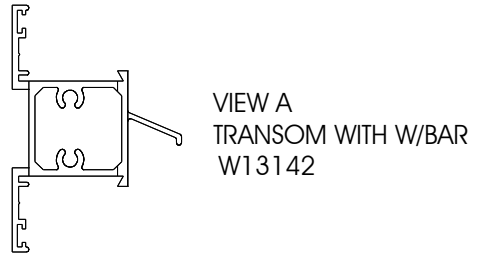
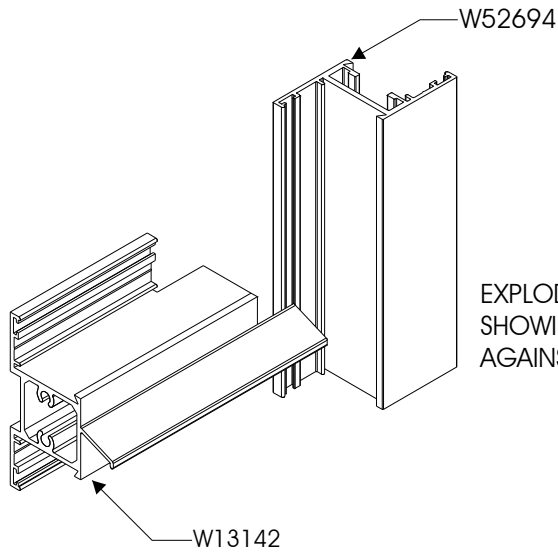

ISOMETRIC VIEW
 SHOWING TRANSOM
 AGAINST FRAME

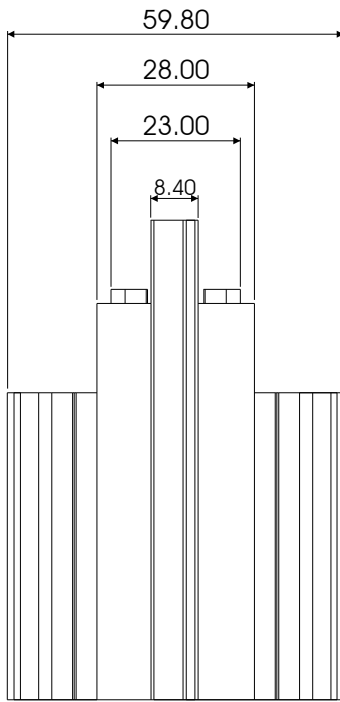
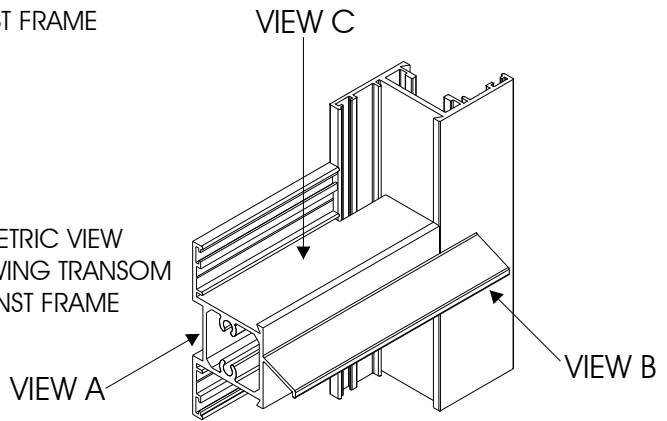

VIEW B

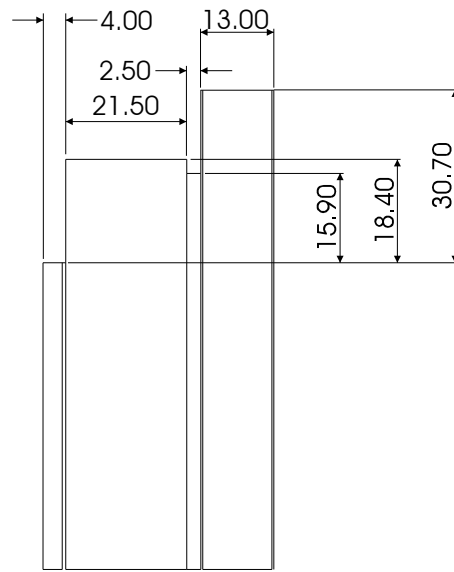

VIEW C

CASEMENT 28
 WINDOW
 TRANSOM WITH W/BAR
 MACHINING DETAIL FOR END MILLING
 ON 54mm OUTER FRAME

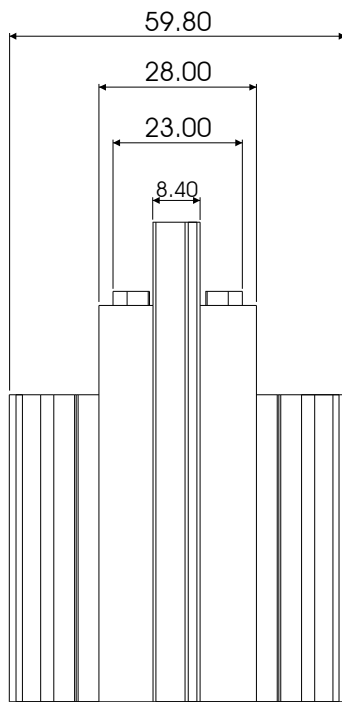
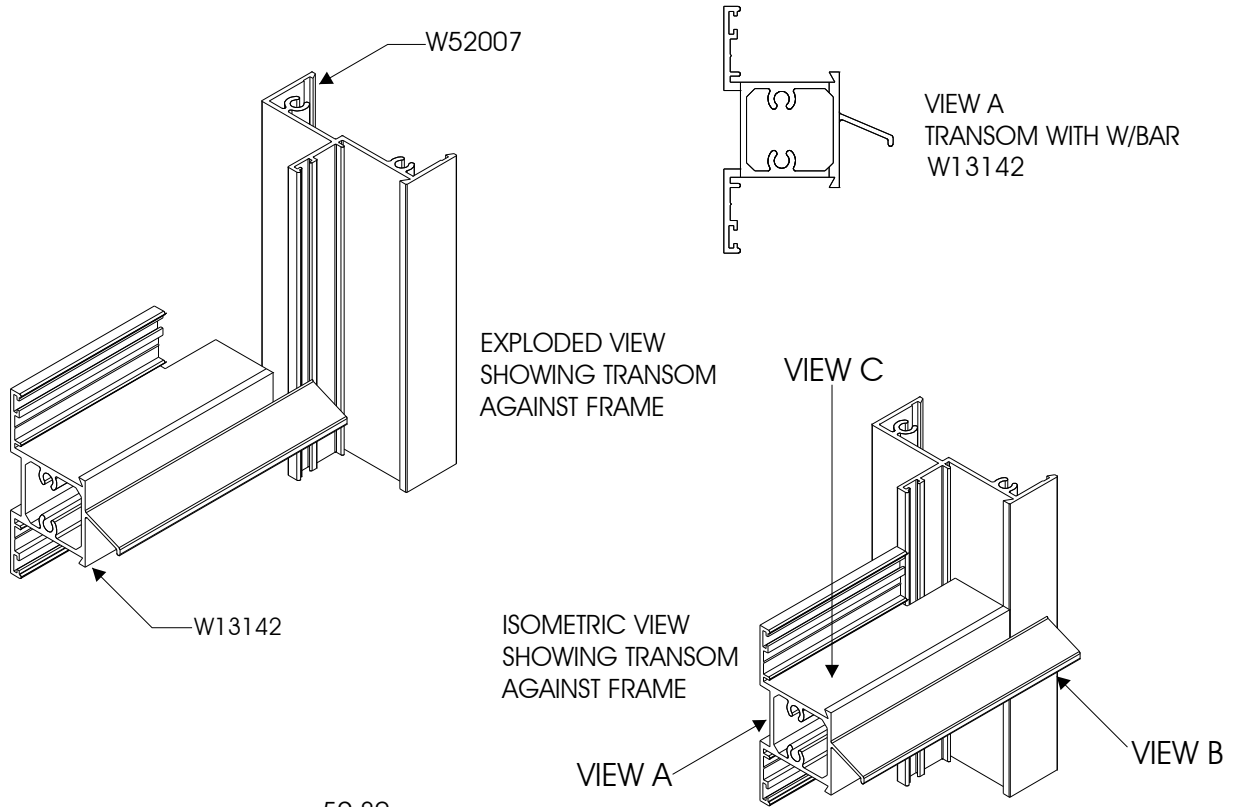

VIEW B

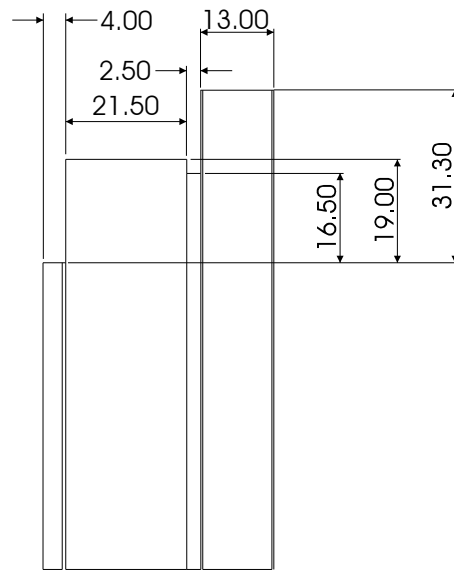

VIEW C

CASEMENT 28
 WINDOW
 TRANSOM WITH W/BAR
 MACHINING DETAIL FOR END MILLING
 ON 70mm OUTER FRAME

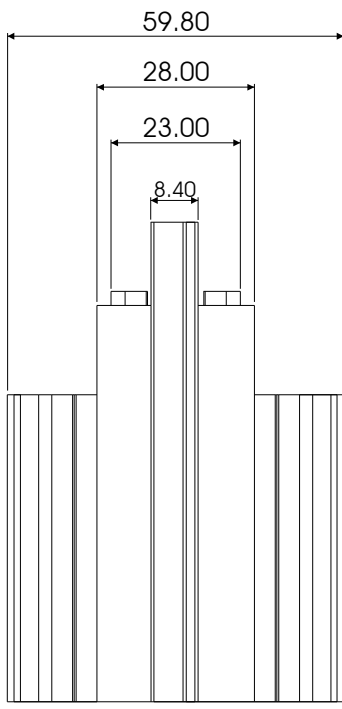
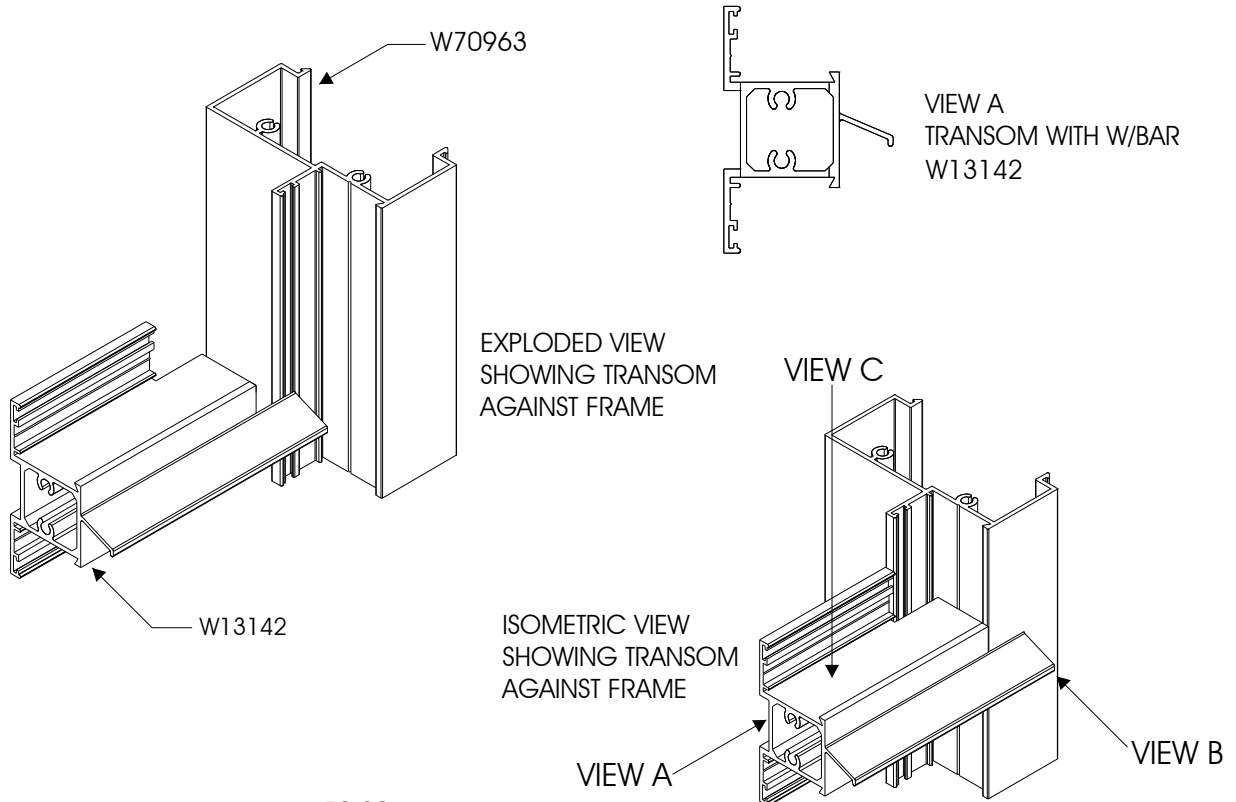

VIEW B

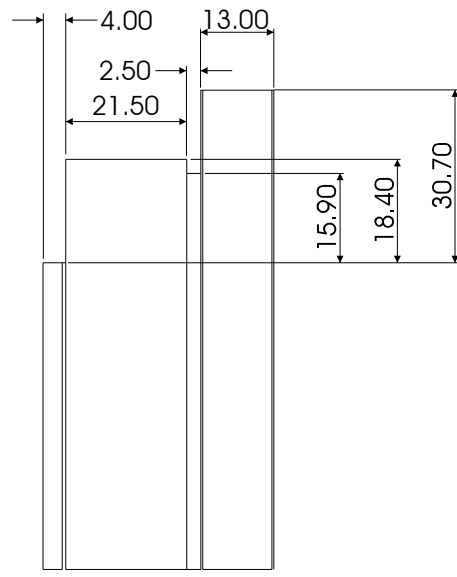

VIEW C

CASEMENT 28
 WINDOW
 TRANSOM WITH W/BAR
 MACHINING DETAIL FOR END MILLING
 ON TUBULAR EQUAL LEG OUTER FRAME

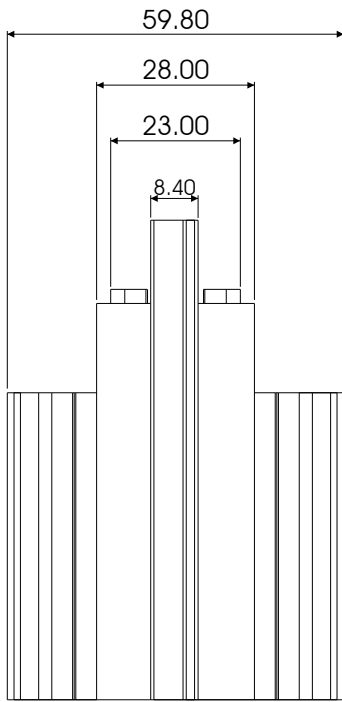
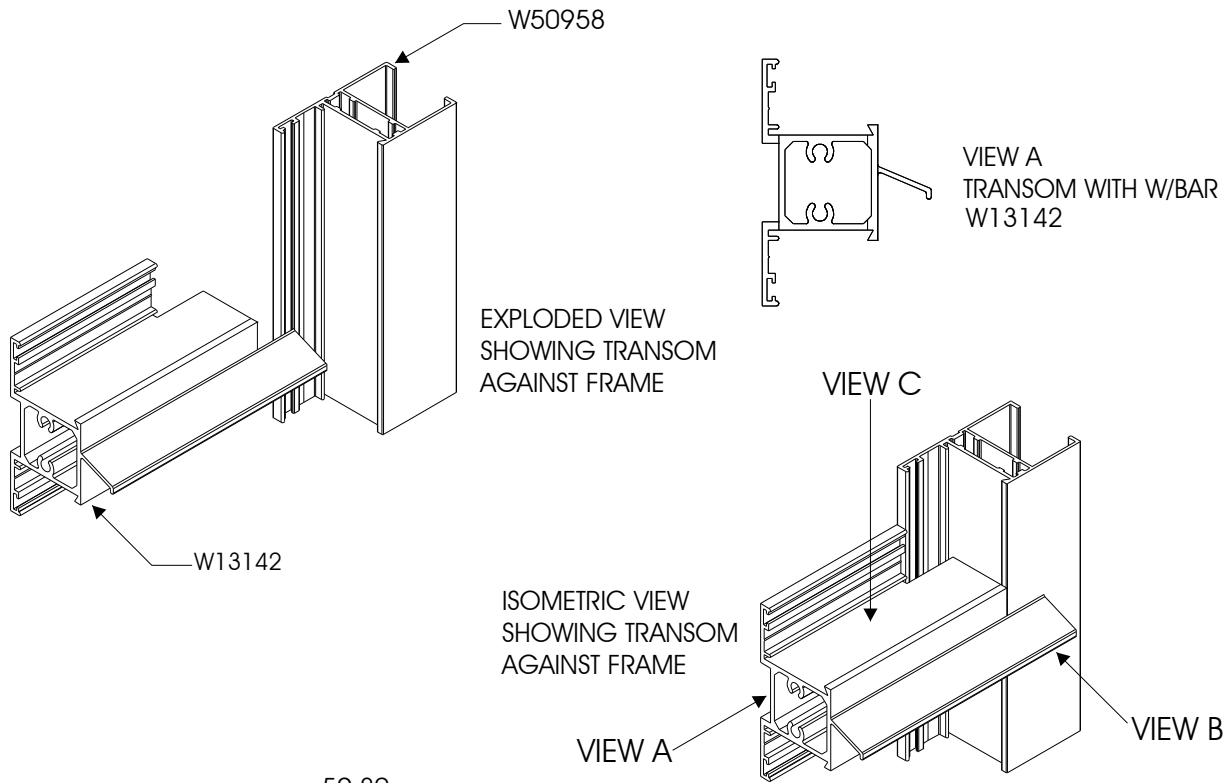

VIEW B

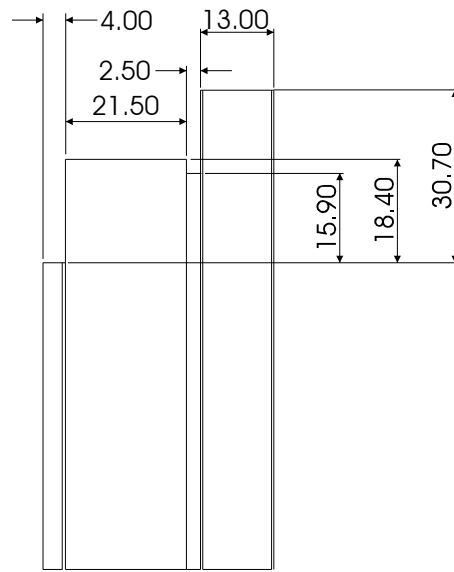

VIEW C

CASEMENT 28
 WINDOW
 54mm MULLION MACHINING
 DETAIL FOR END MILLING
 ON EQUAL LEG OUTER FRAME

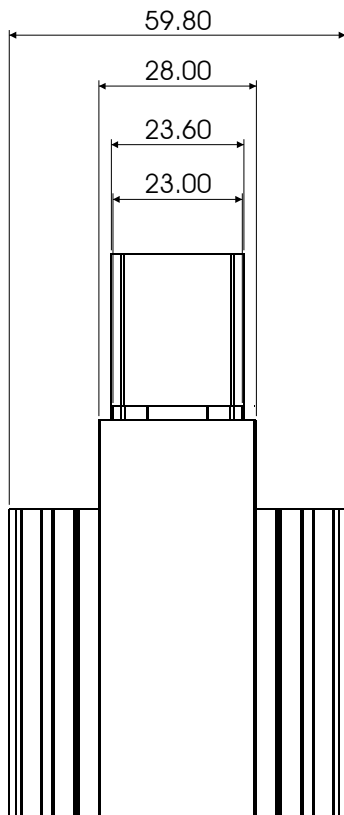
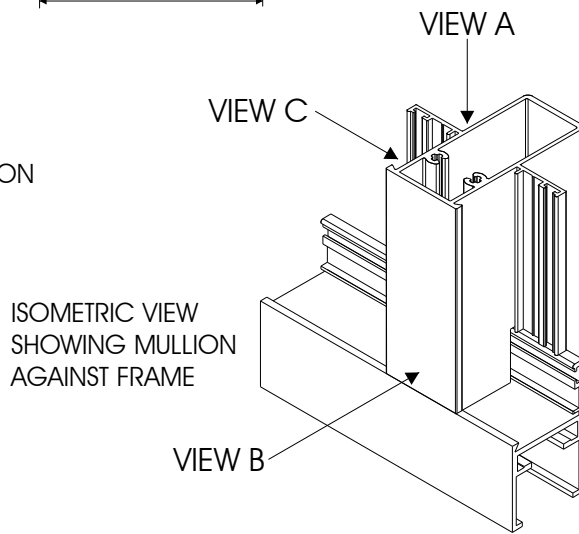
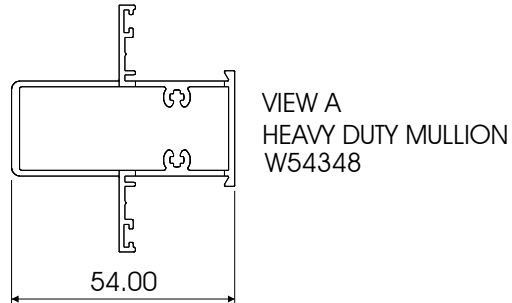
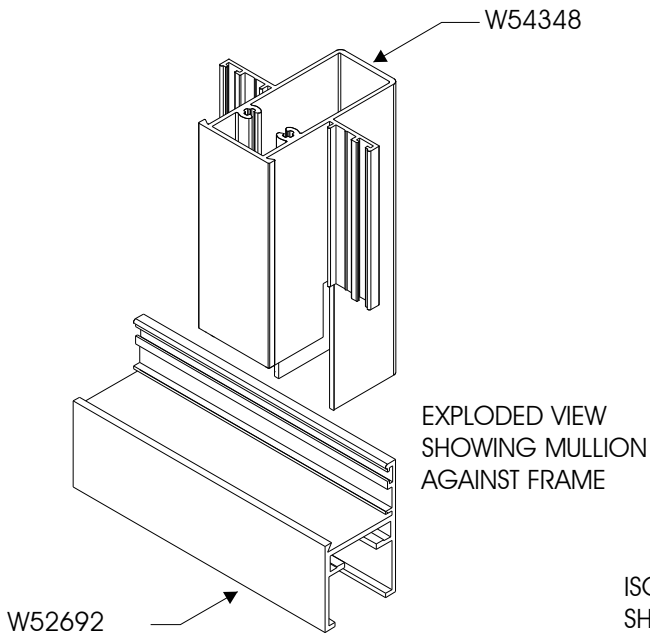

VIEW B

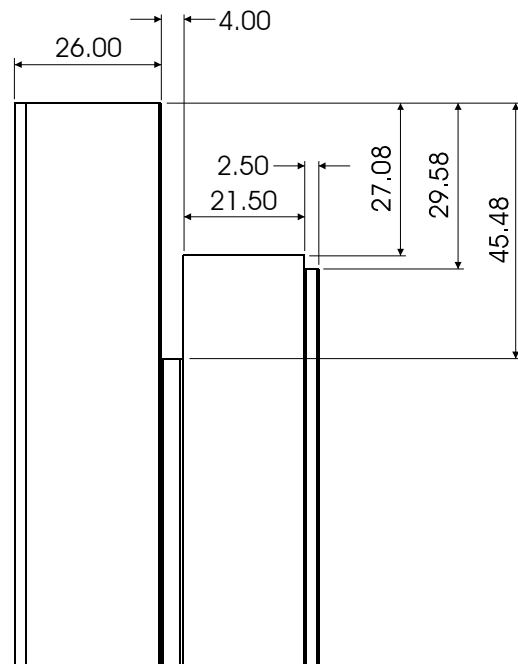

VIEW C

CASEMENT 28
 WINDOW
 54mm MULLION MACHINING
 DETAIL FOR END MILLING
 ON UNEQUAL LEG OUTER FRAME

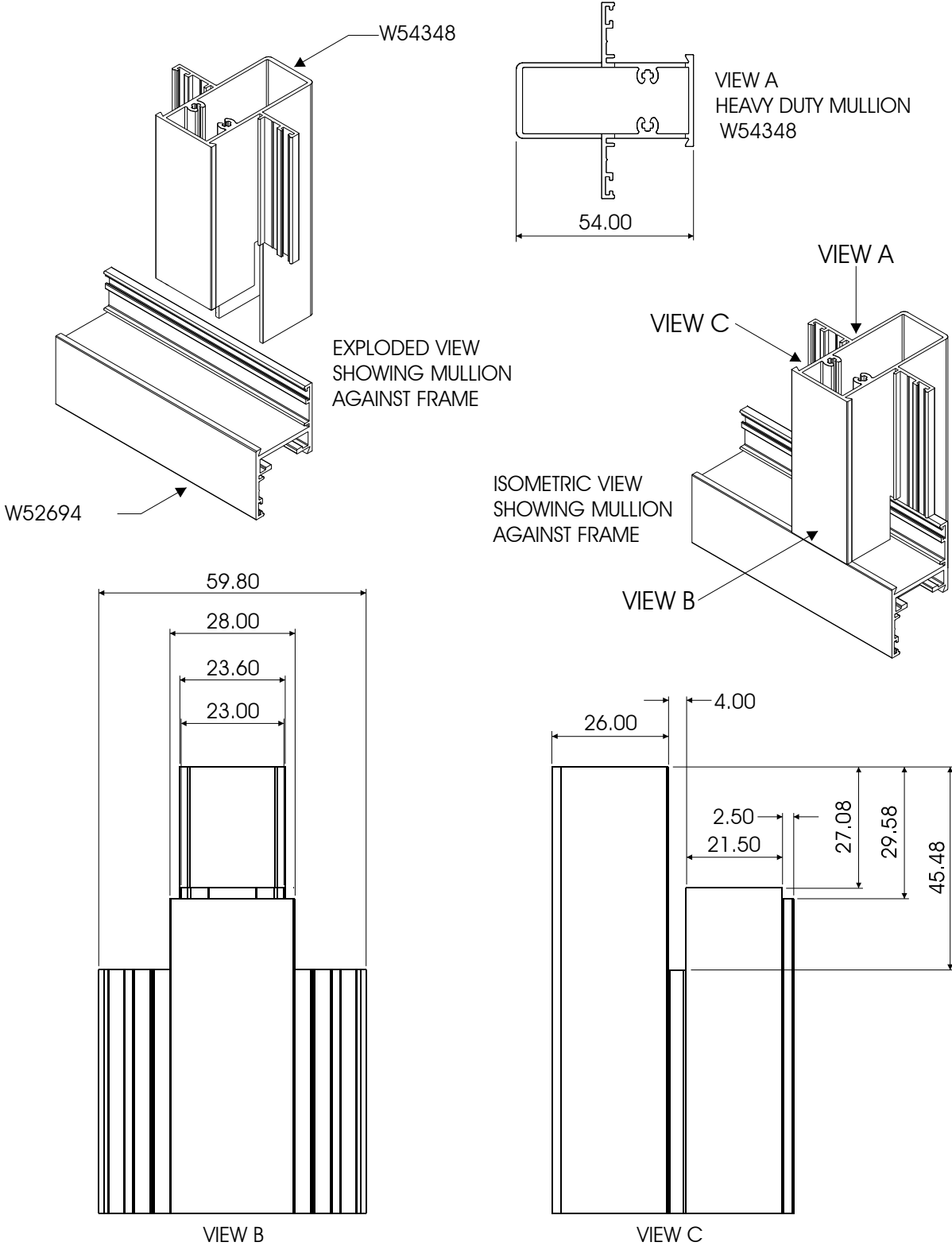

CASEMENT 28
 WINDOW
 54mm MULLION MACHINING
 DETAIL FOR END MILLING
 ON 54mm OUTER FRAME

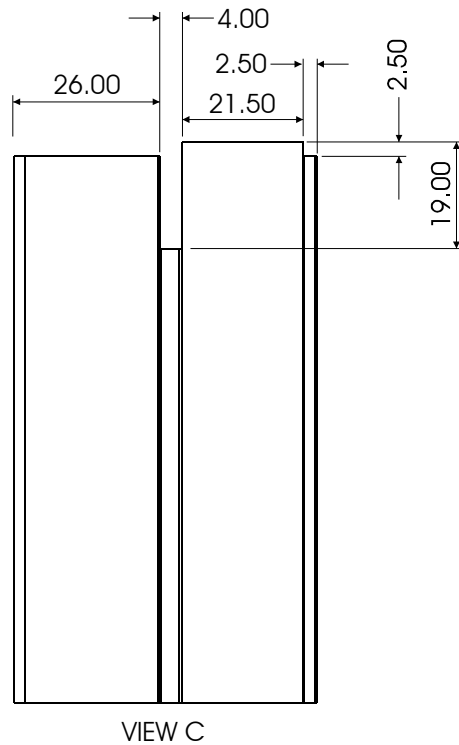
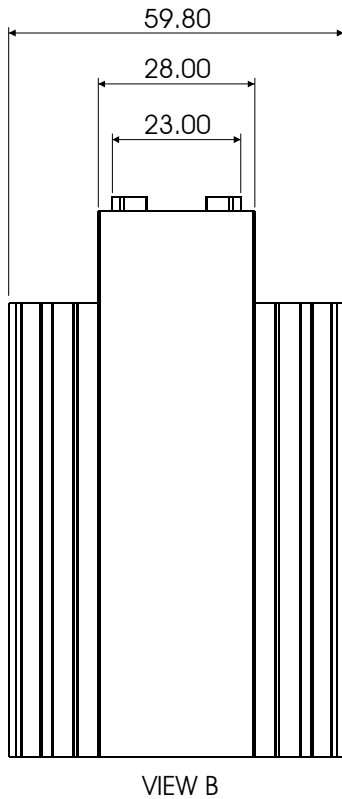
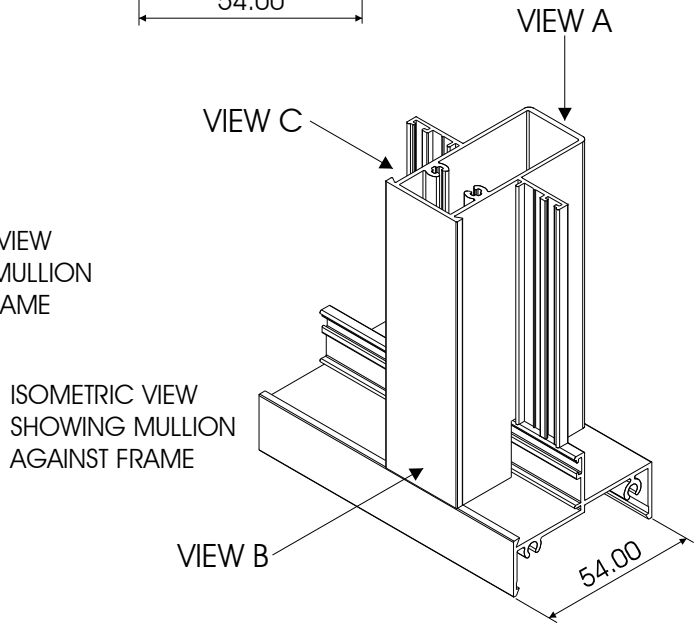
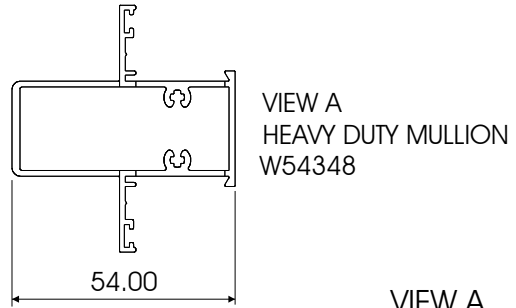
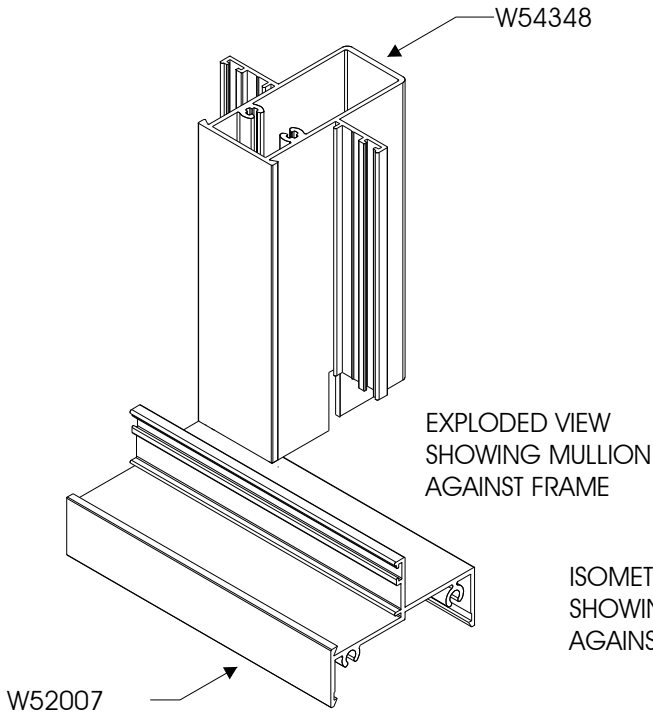

CASEMENT 28
 WINDOW
 54mm MULLION MACHINING
 DETAIL FOR END MILLING
 ON 70mm OUTER FRAME

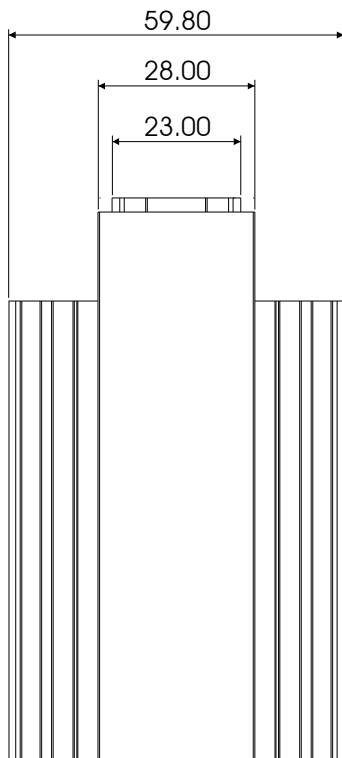
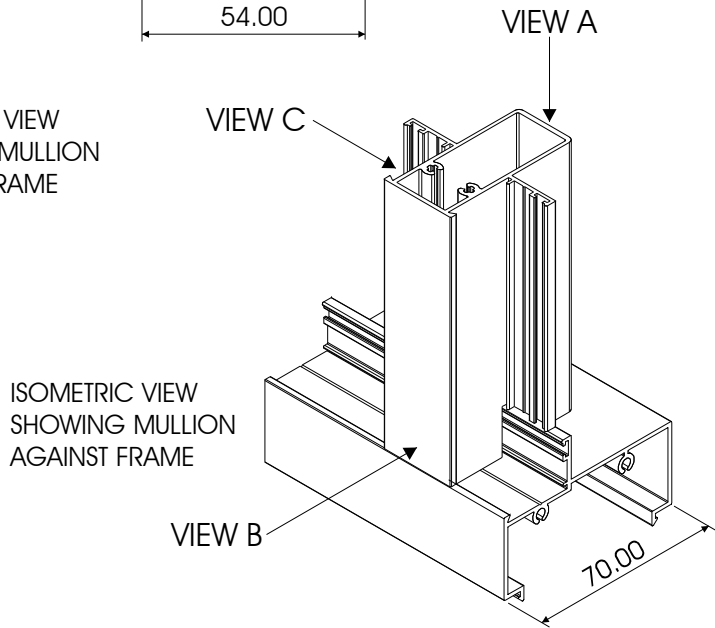
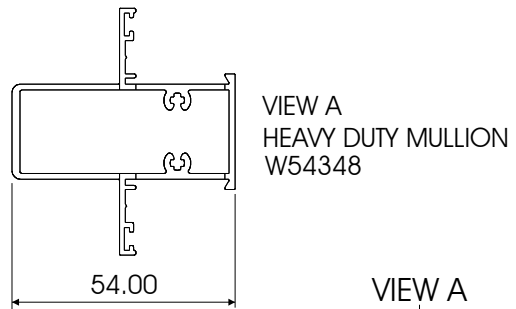
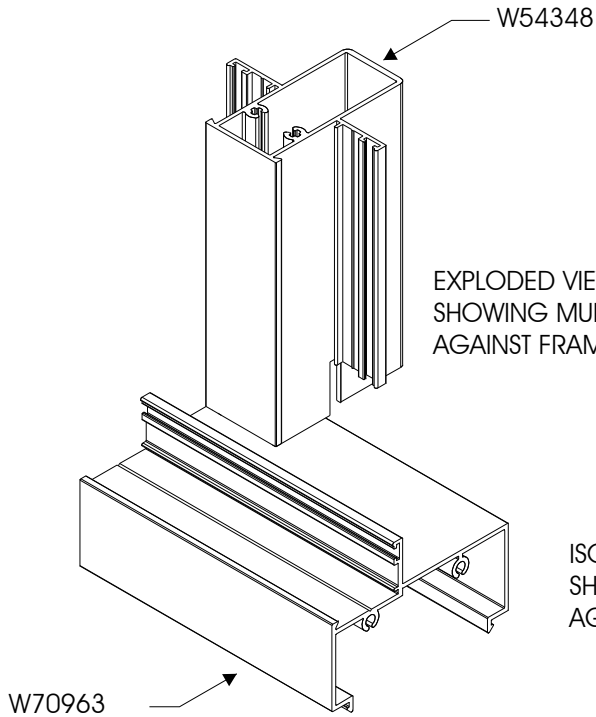

VIEW B

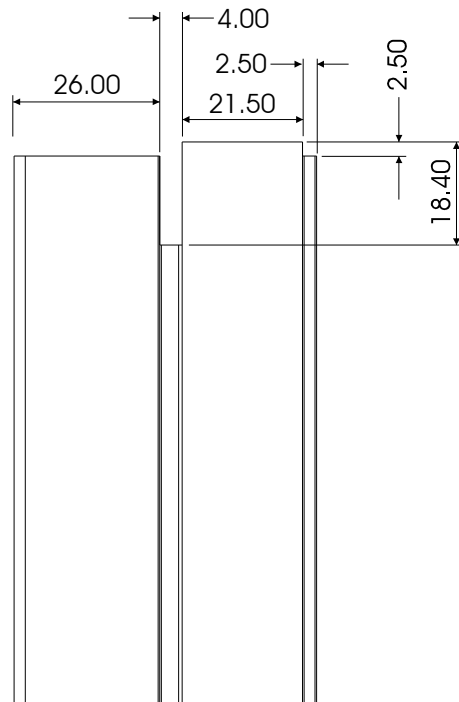

VIEW C

CASEMENT 28
 WINDOW
 54mm MULLION MACHINING
 DETAIL FOR END MILLING ON
 TUBULAR EQUAL LEG OUTER FRAME

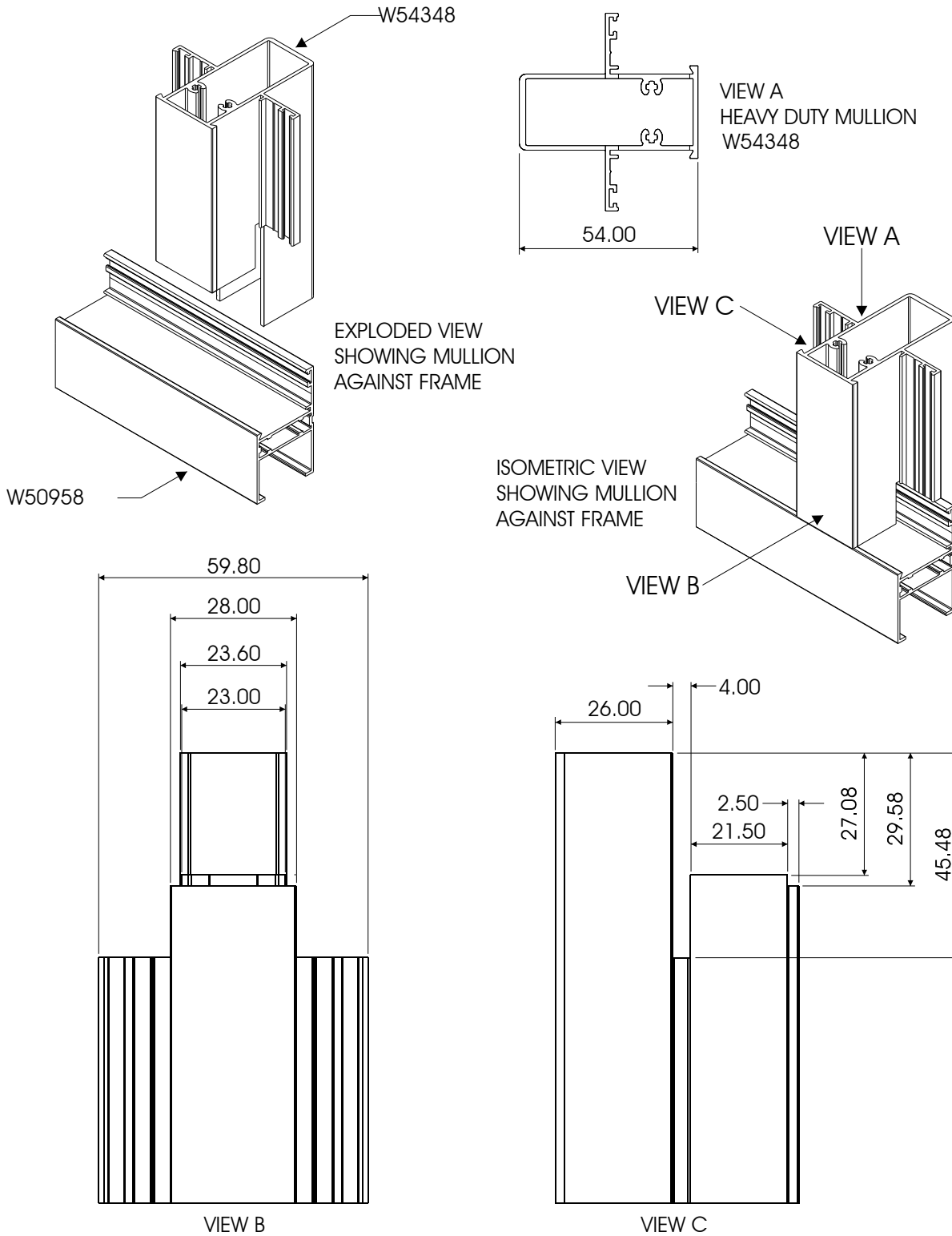

CASEMENT 28
 WINDOW
 70mm MULLION MACHINING
 DETAIL FOR END MILLING
 ON EQUAL LEG OUTER FRAME

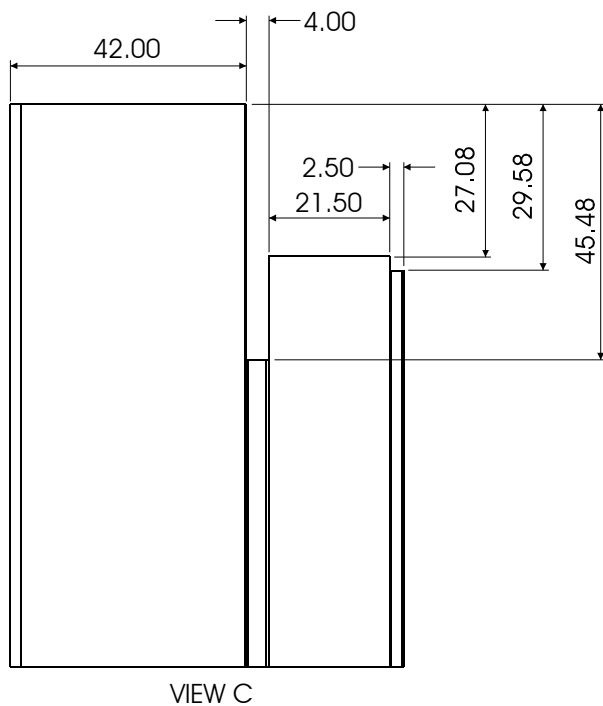
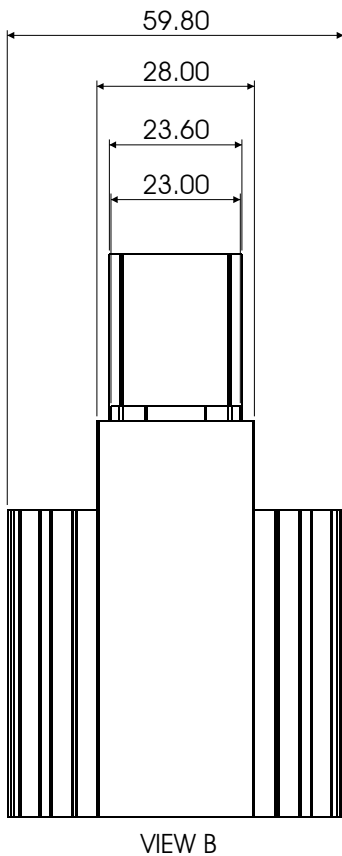
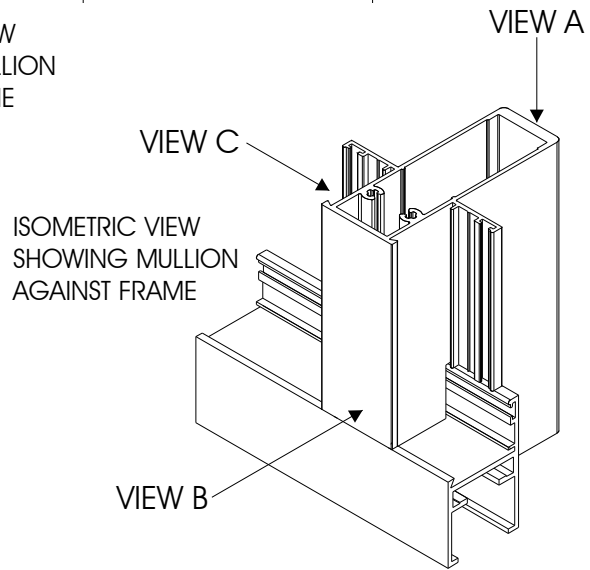
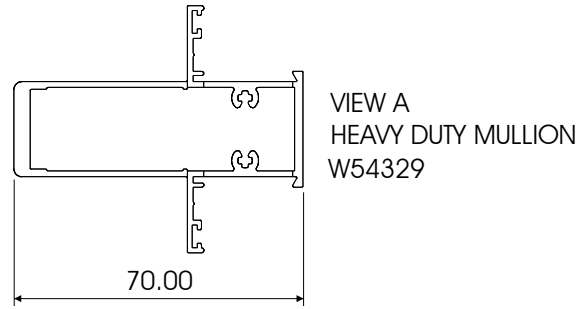
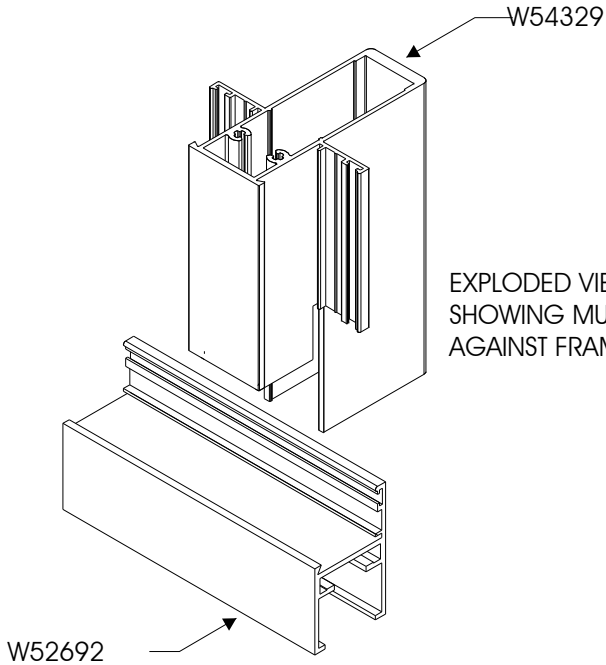

CASEMENT 28
 WINDOW
 70mm MULLION MACHINING
 DETAIL FOR END MILLING
 ON UNEQUAL LEG OUTER FRAME

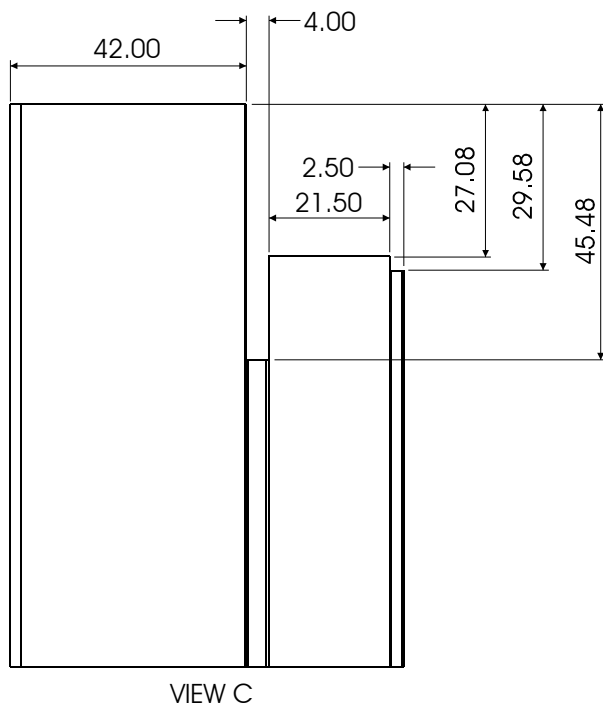
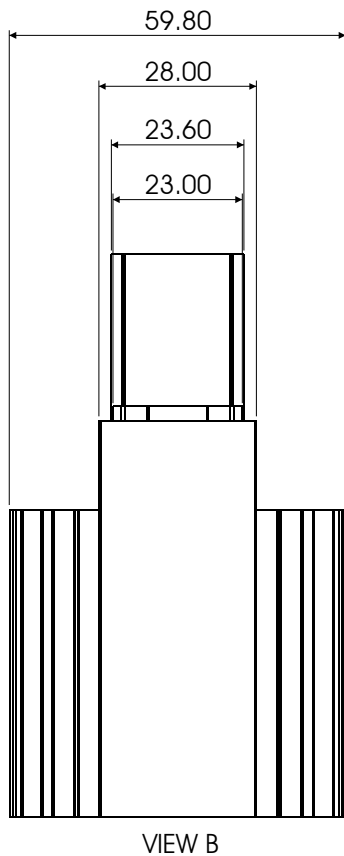
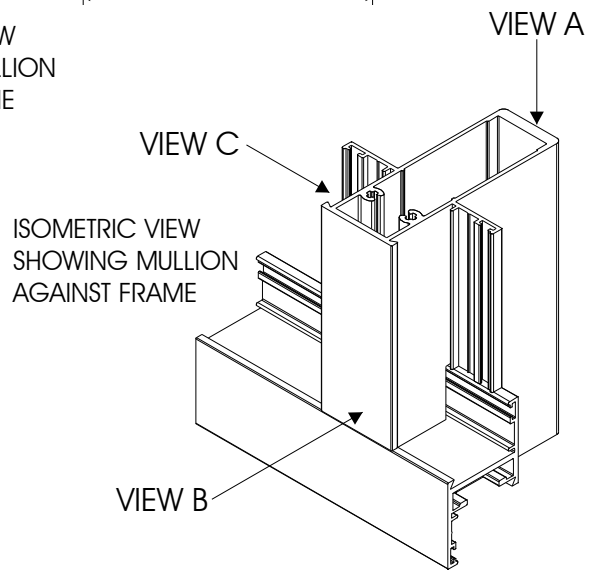
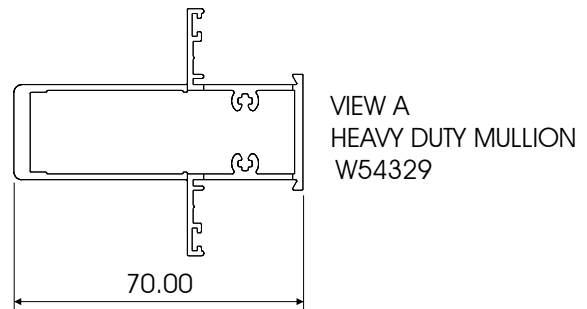
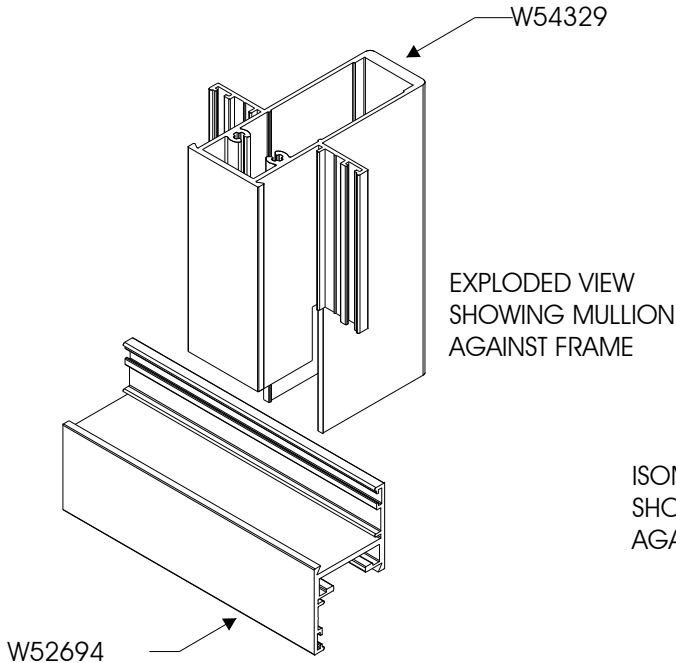

CASEMENT 28
 WINDOW
 70mm MULLION MACHINING
 DETAIL FOR END MILLING
 ON 54mm OUTER FRAME

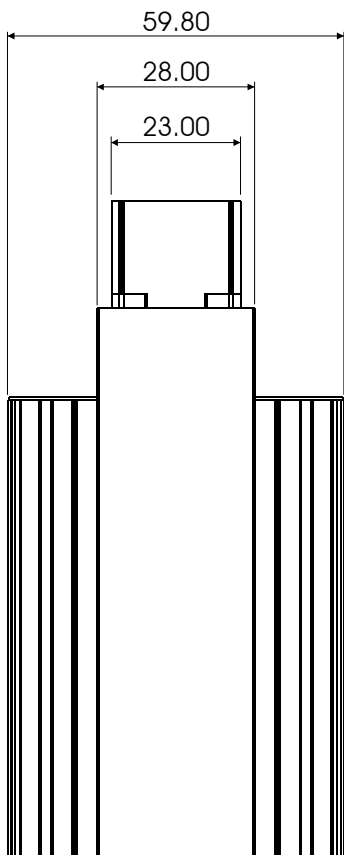
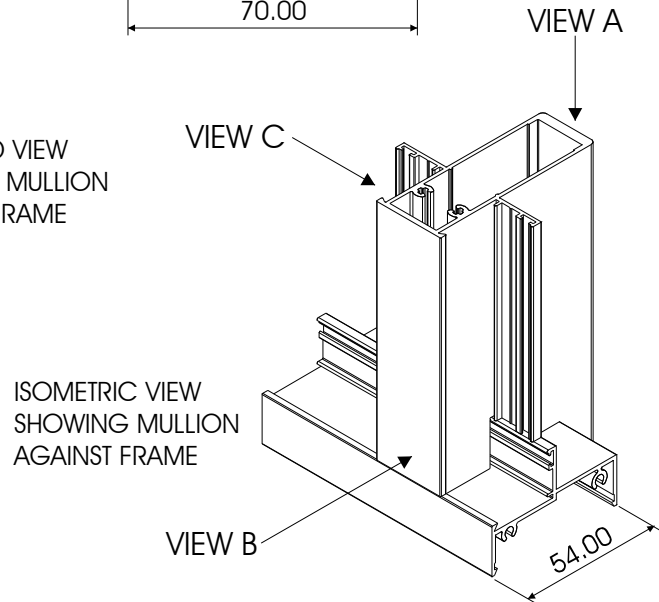
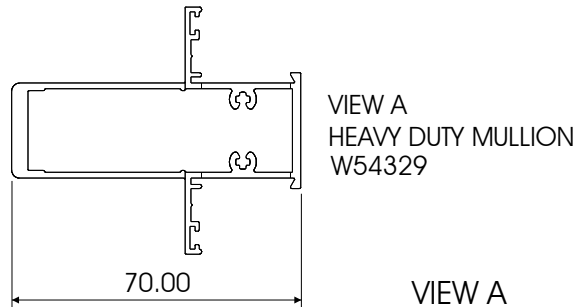
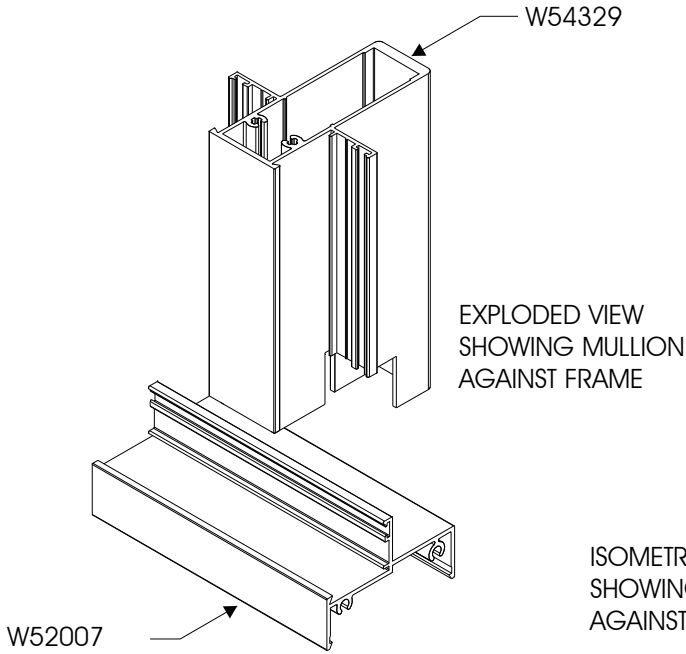

VIEW B

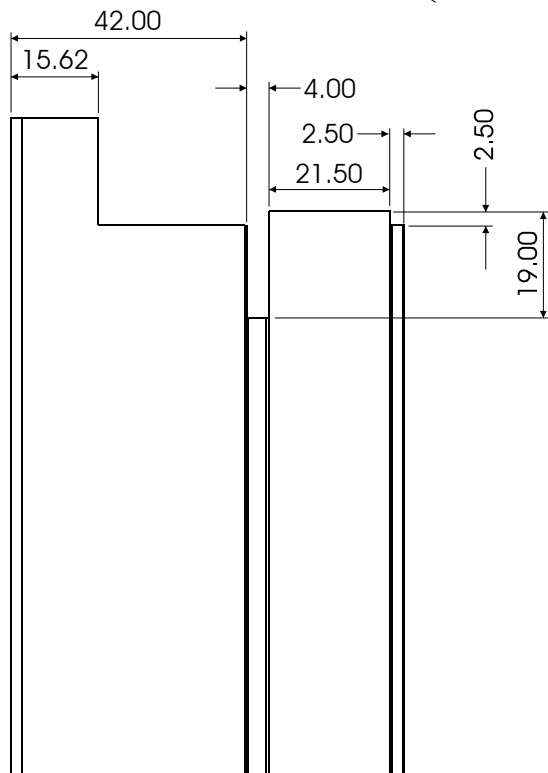

VIEW C

CASEMENT 28
 WINDOW
 70mm MULLION MACHINING
 DETAIL FOR END MILLING
 ON 70mm OUTER FRAME

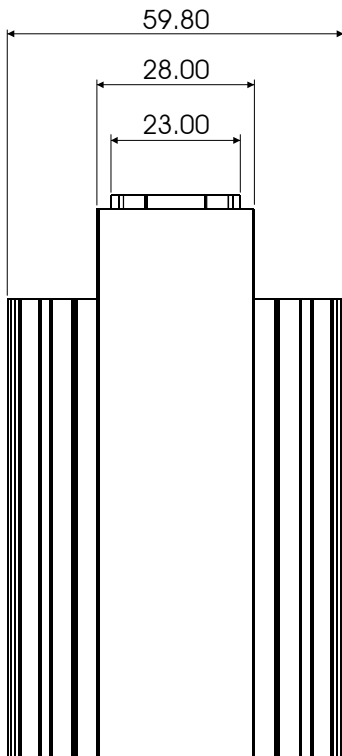
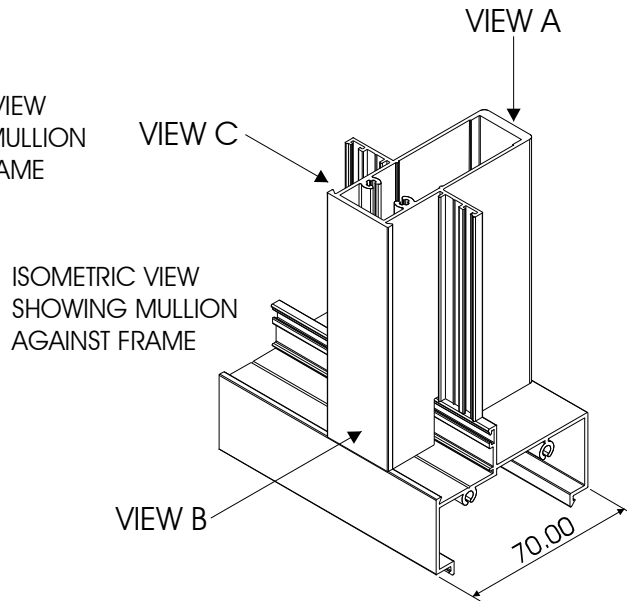
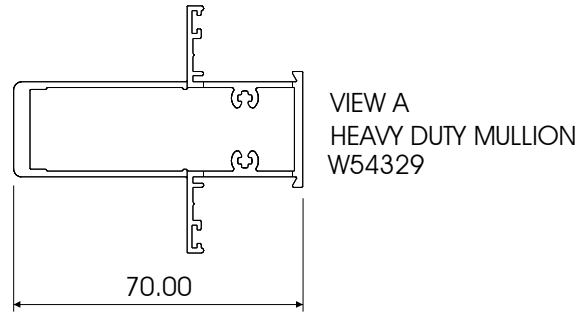
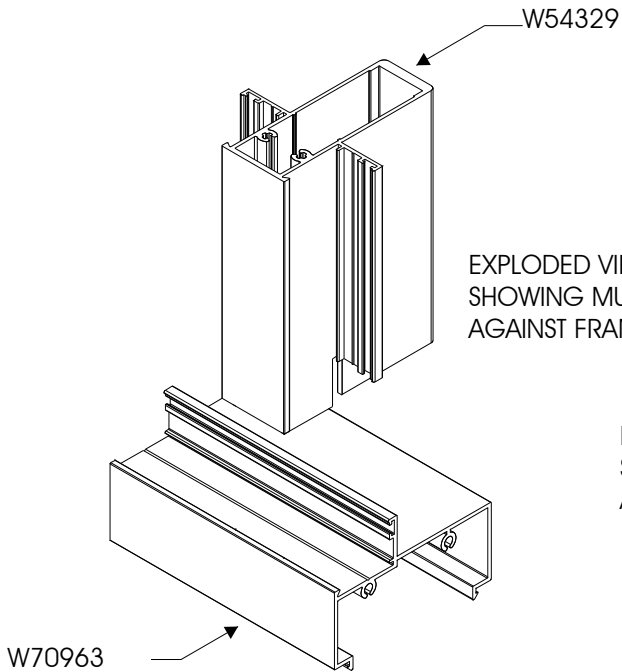

VIEW B

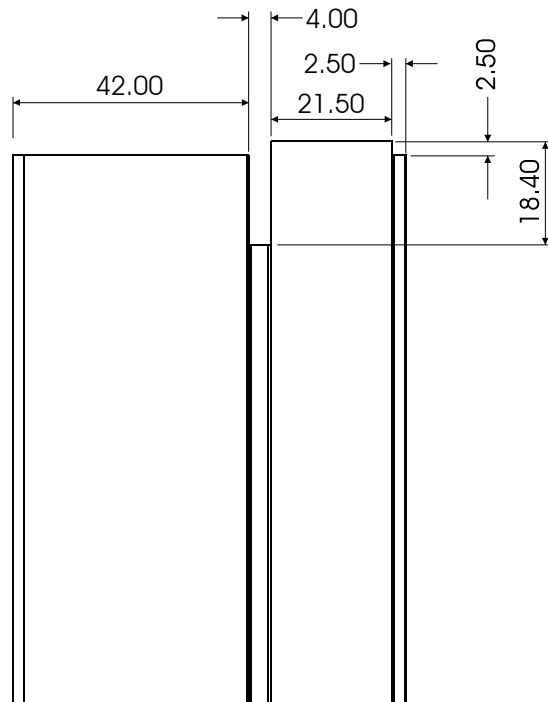

VIEW C

CASEMENT 28
 WINDOW
 70mm MULLION MACHINING
 DETAIL FOR END MILLING
 ON TUBULAR EQUAL LEG OUTER FRAME

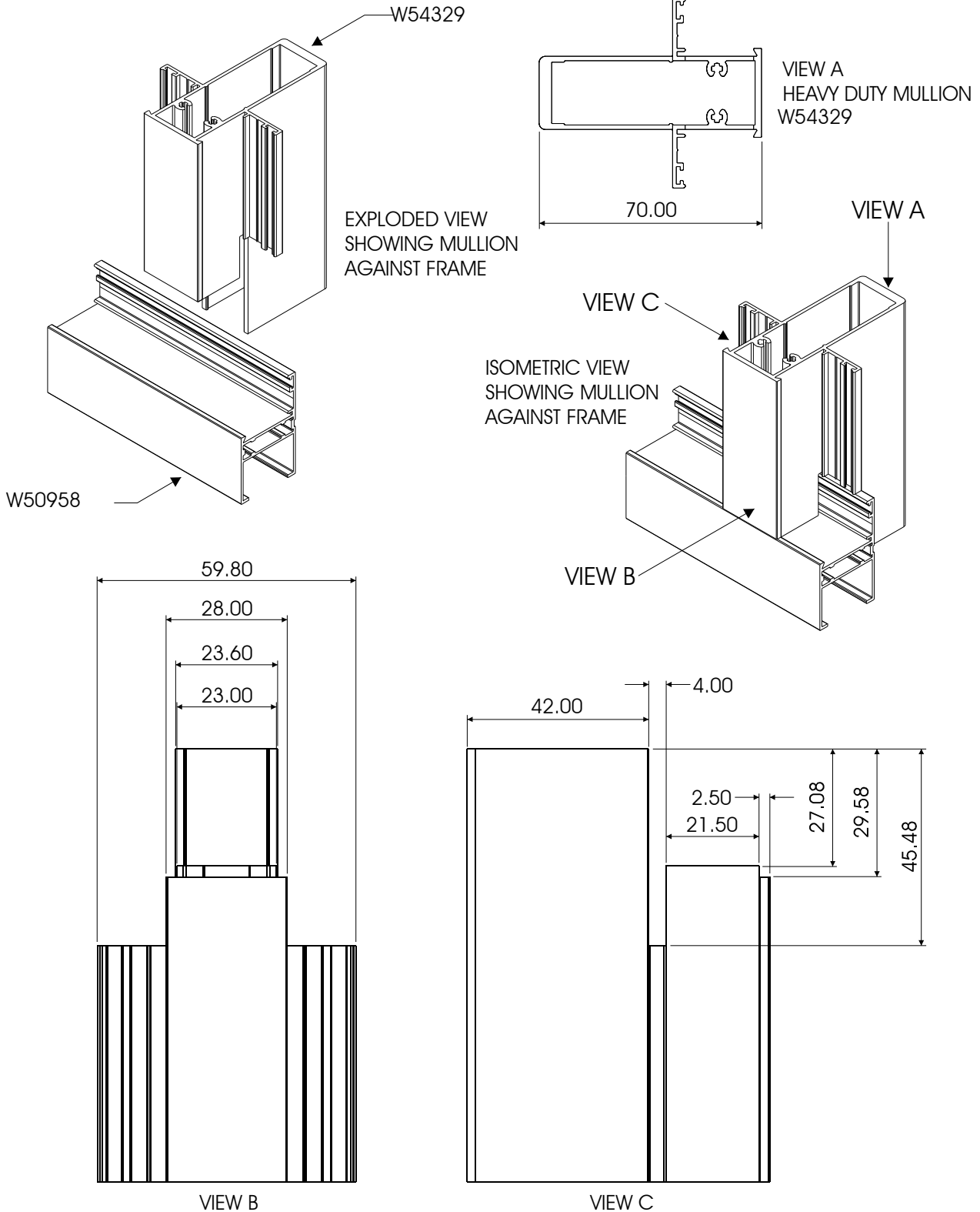

CASEMENT 28
 WINDOW
 COTTAGE PANE MULLION
 MACHINING DETAIL FOR END MILLING
 ON EQUAL LEG OUTER FRAME

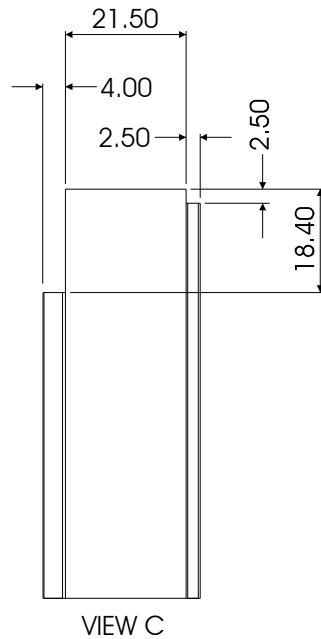
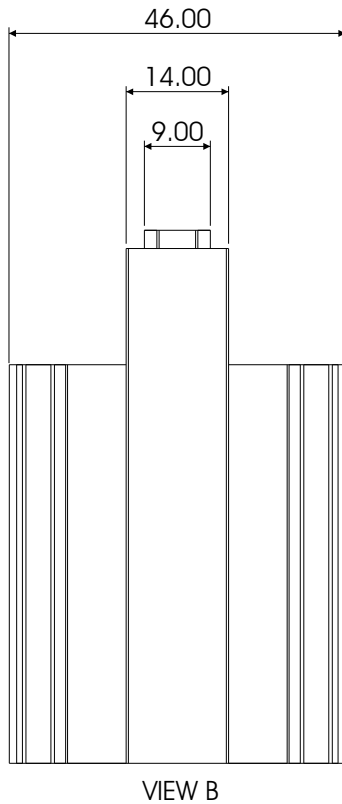
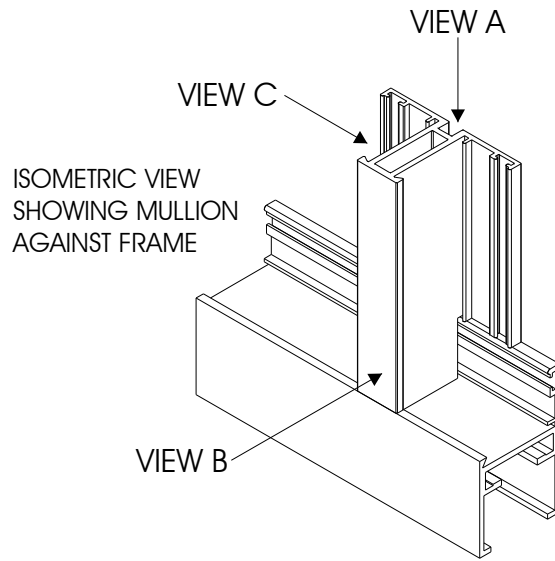
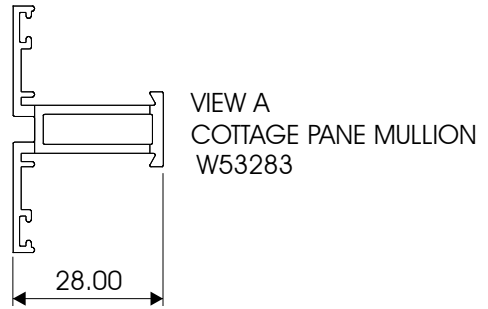
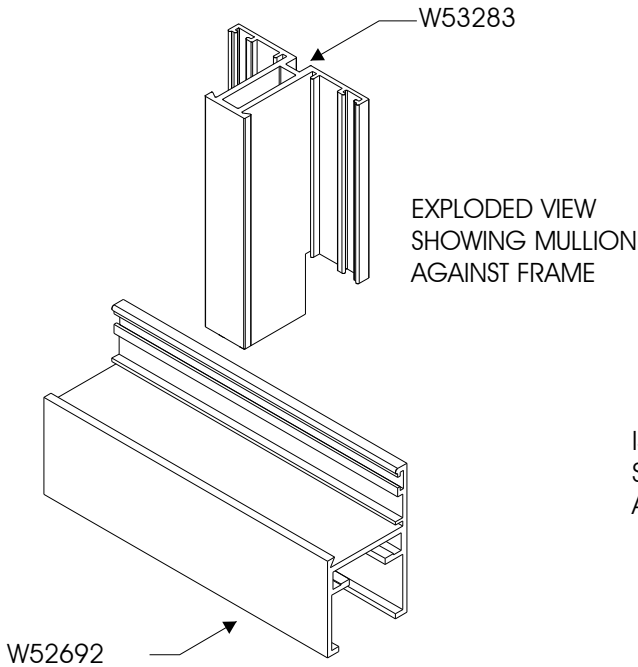

CASEMENT 28
 WINDOW
 COTTAGE PANE MULLION
 MACHINING DETAIL FOR END MILLING
 ON UNEQUAL LEG OUTER FRAME

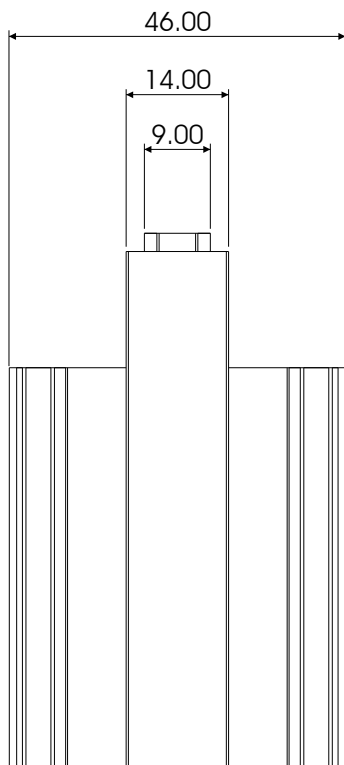
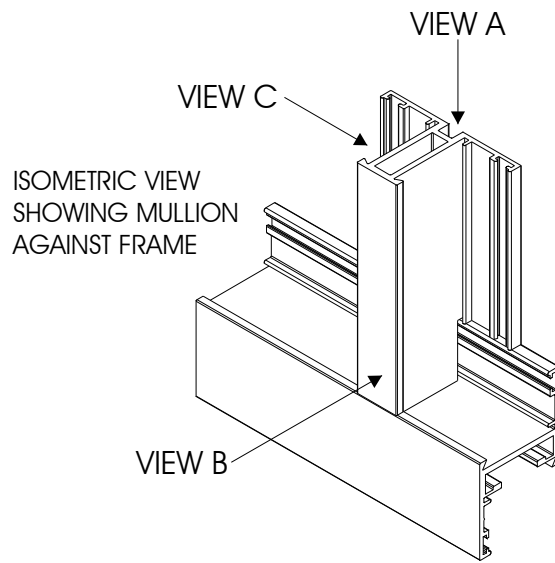
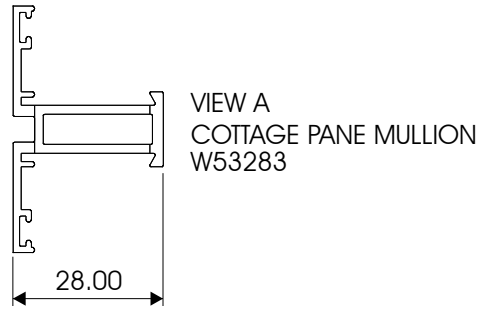
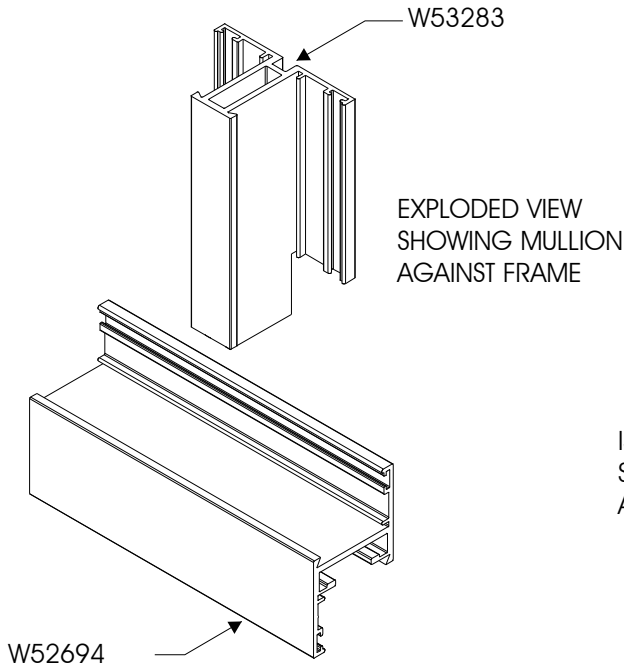

VIEW B

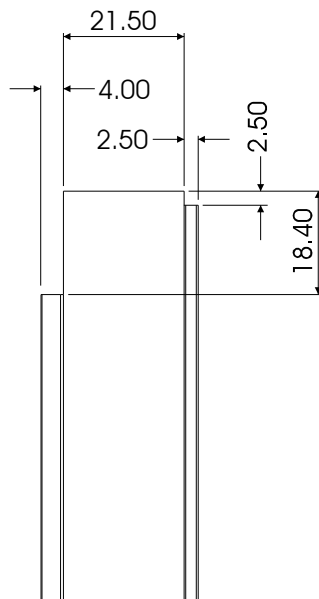

VIEW C

CASEMENT 28
 WINDOW
 COTTAGE PANE MULLION
 MACHINING DETAIL FOR END MILLING
 ON 54mm OUTER FRAME

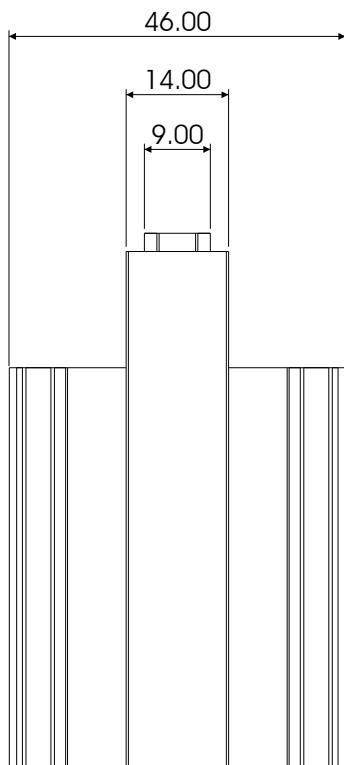
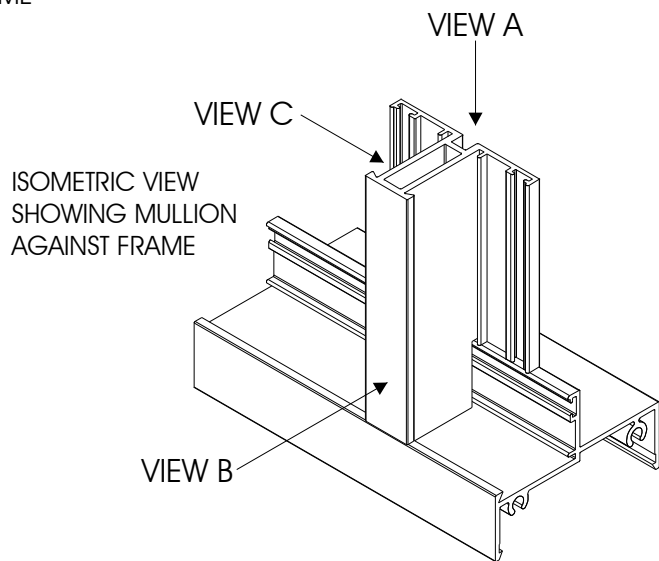
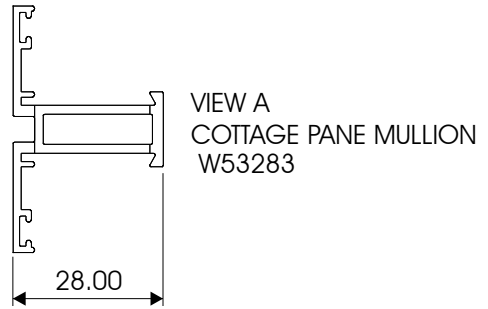
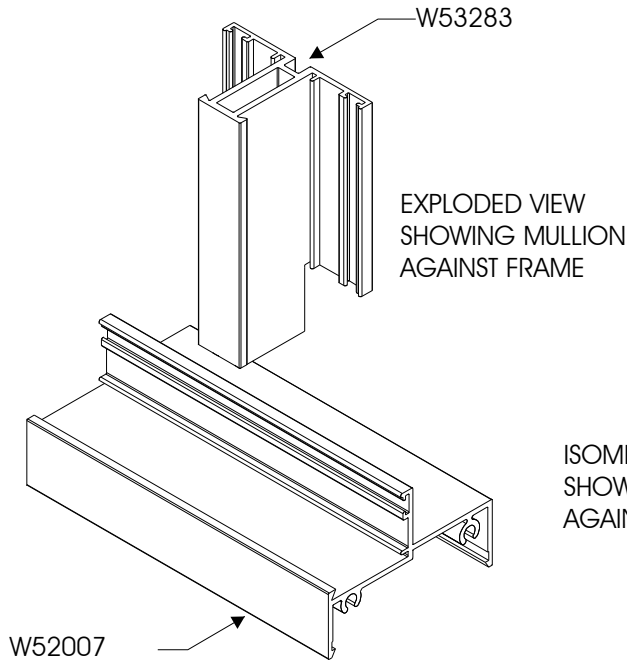

VIEW B

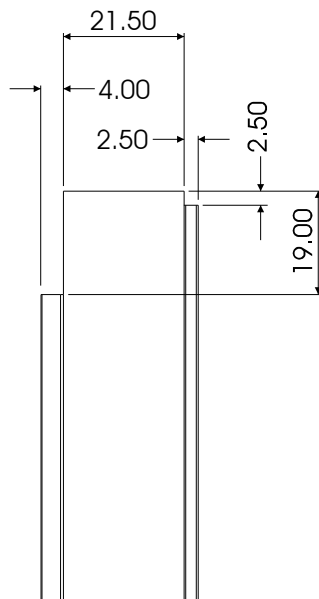

VIEW C

CASEMENT 28
 WINDOW
 COTTAGE PANE MULLION MACHINING
 DETAIL FOR END MILLING
 ON 70mm OUTER FRAME

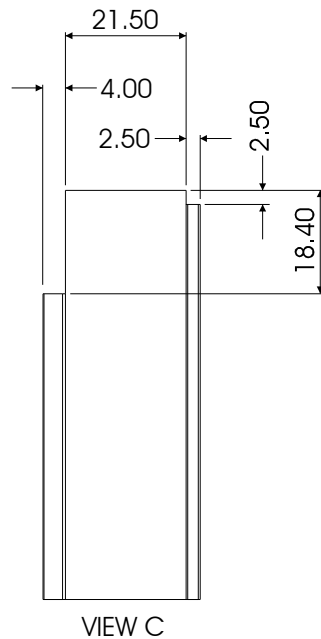
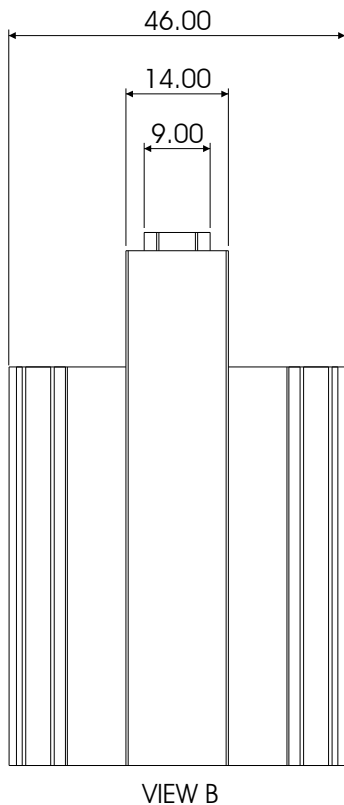
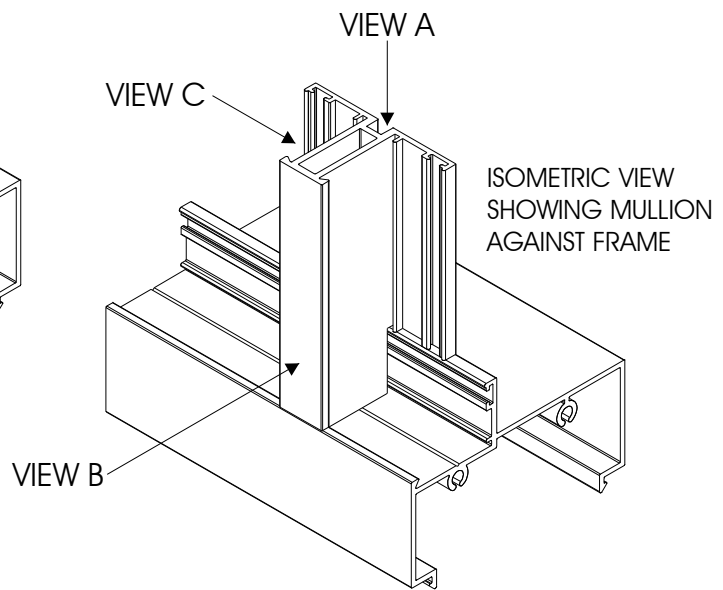
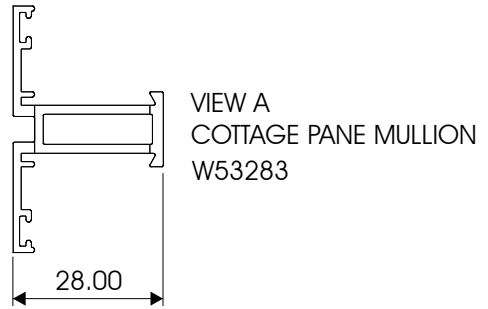
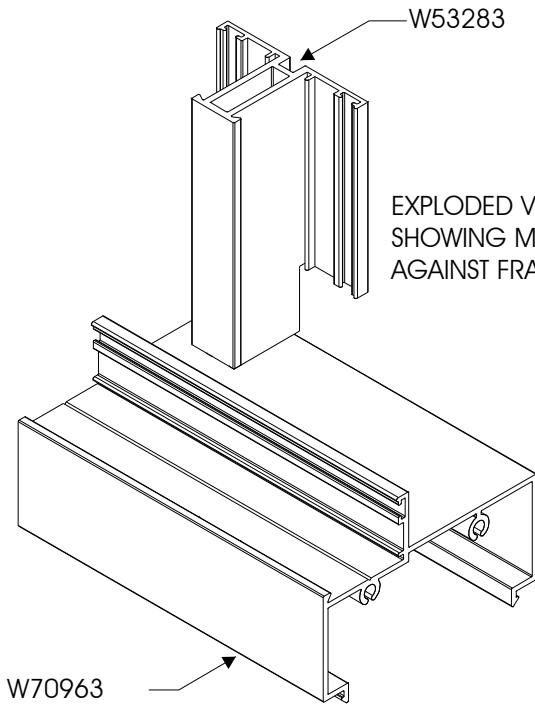

CASEMENT 28
 WINDOW
 COTTAGE PANE MULLION
 MACHINING DETAIL FOR END MILLING
 ON TUBULAR EQUAL LEG OUTER FRAME

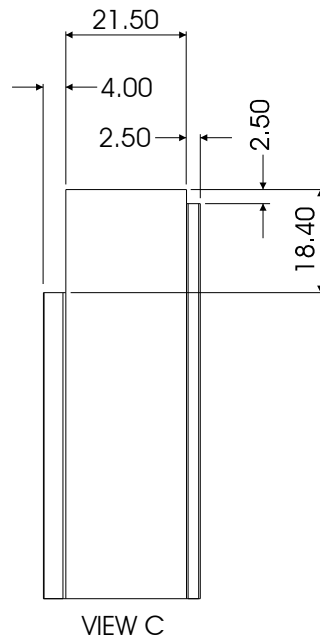
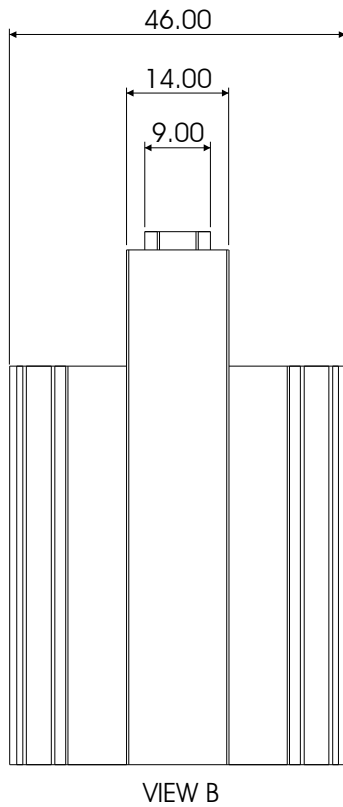
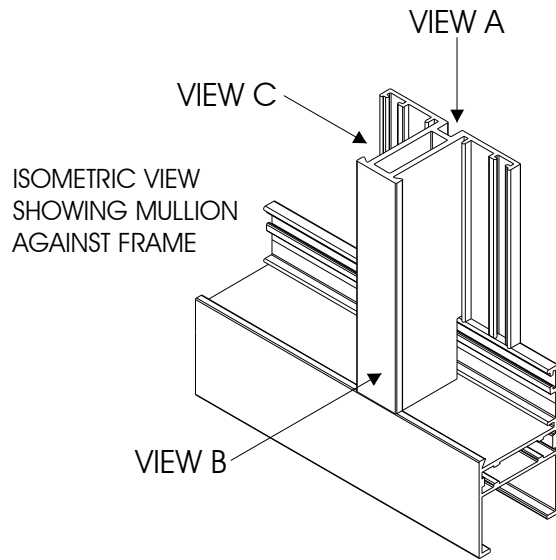
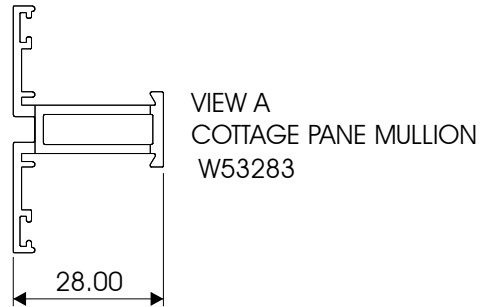
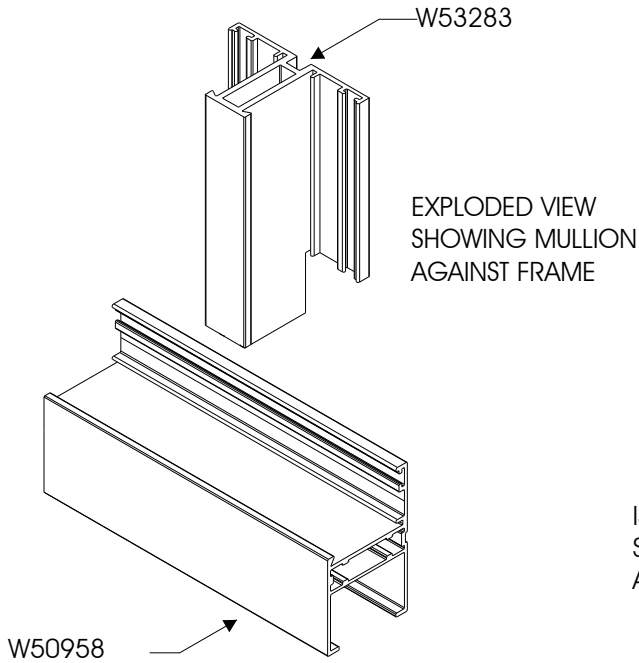

CASEMENT 28
 WINDOW
 LITE MULLION MACHINING DETAIL
 FOR END MILLING
 ON EQUAL LEG OUTER FRAME

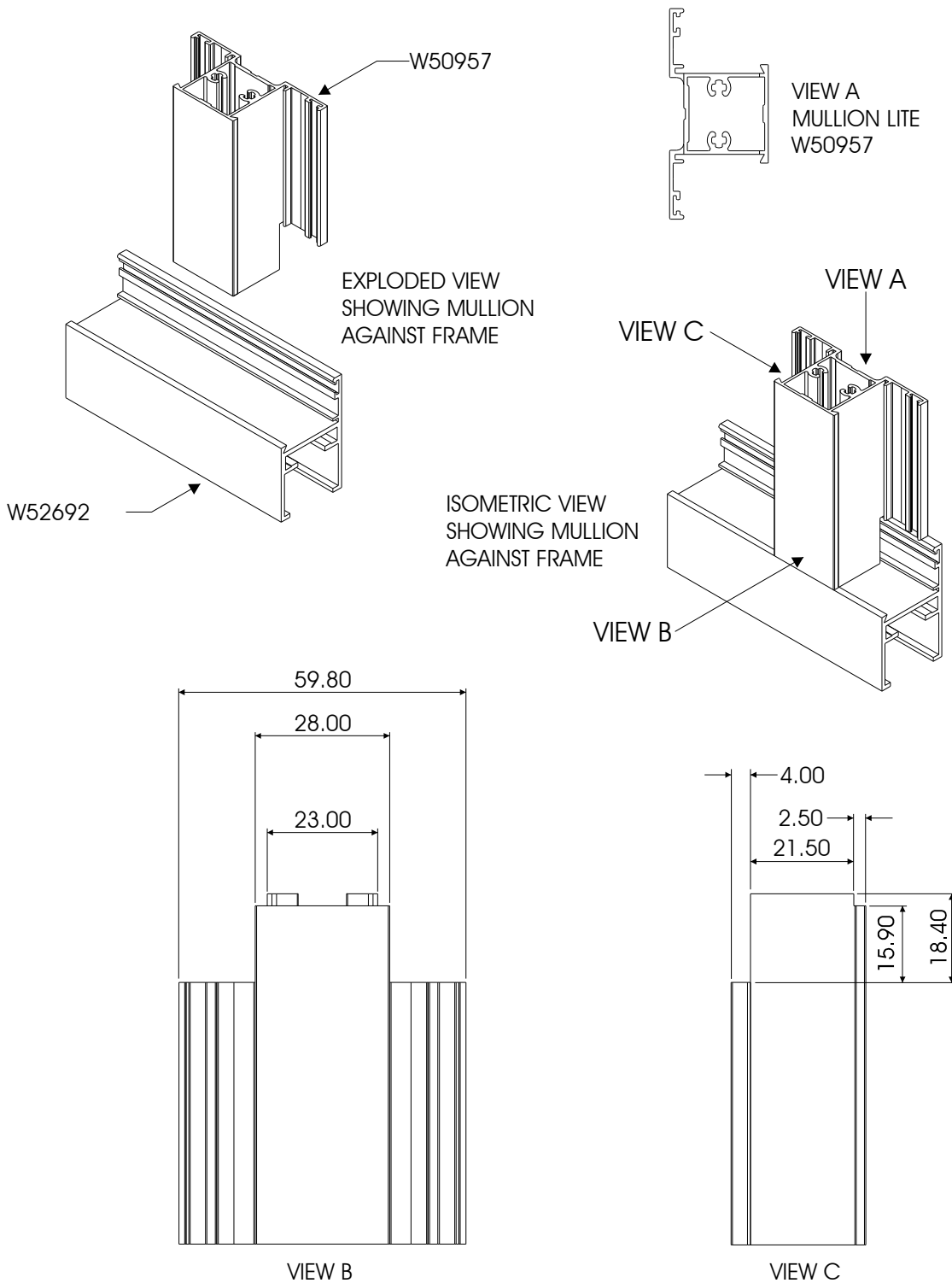

CASEMENT 28
 WINDOW
 LITE MULLION MACHINING DETAIL
 FOR END MILLING
 ON UNEQUAL LEG OUTER FRAME

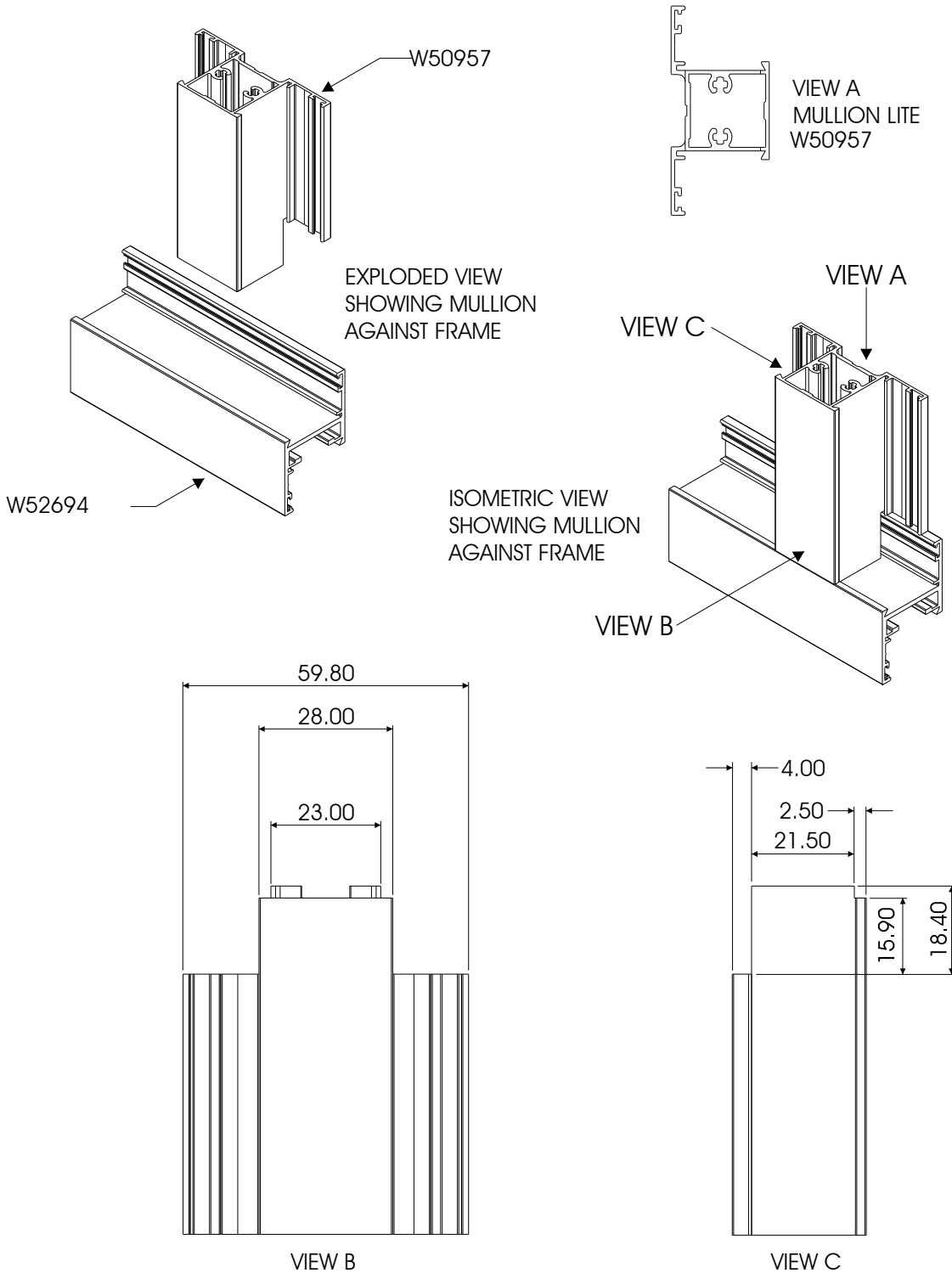

CASEMENT 28
 WINDOW
 LITE MULLION MACHINING DETAIL
 FOR END MILLING
 ON 54mm OUTER FRAME

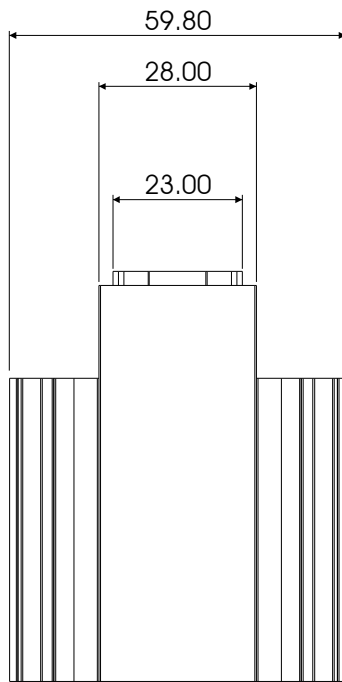
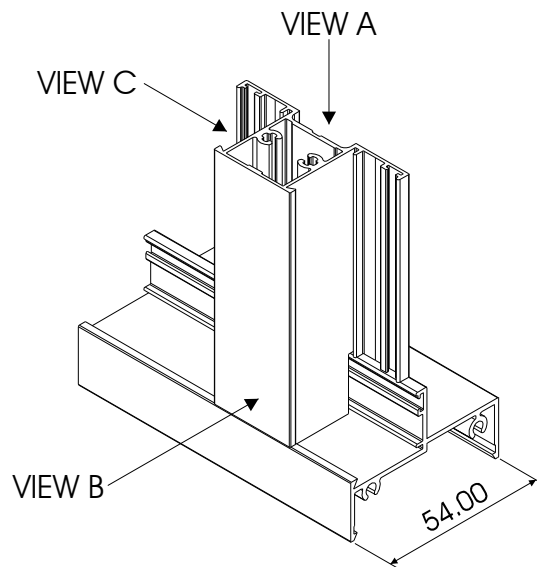
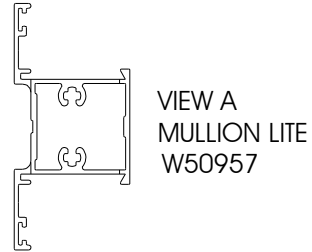
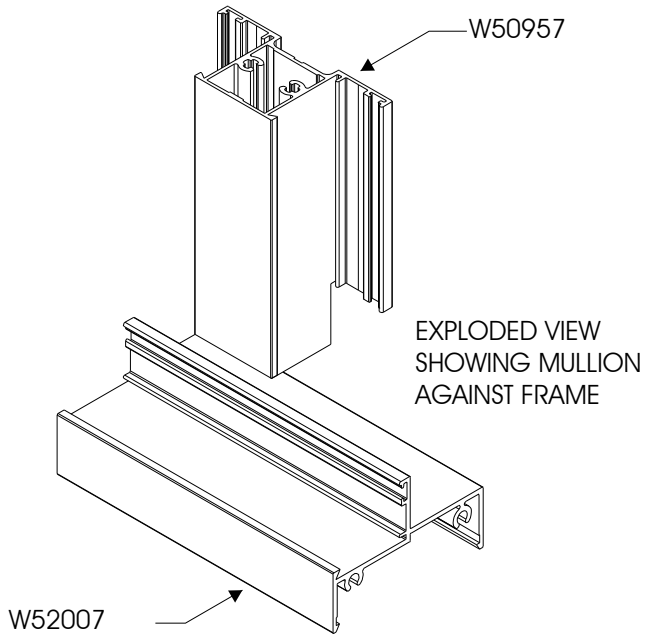

VIEW B

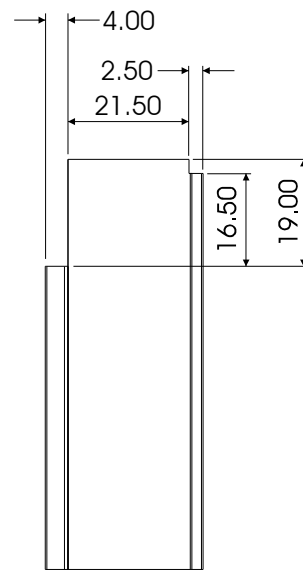

VIEW C

CASEMENT 28
 WINDOW
 LITE MULLION MACHINING DETAIL
 FOR END MILLING
 ON 70mm OUTER FRAME

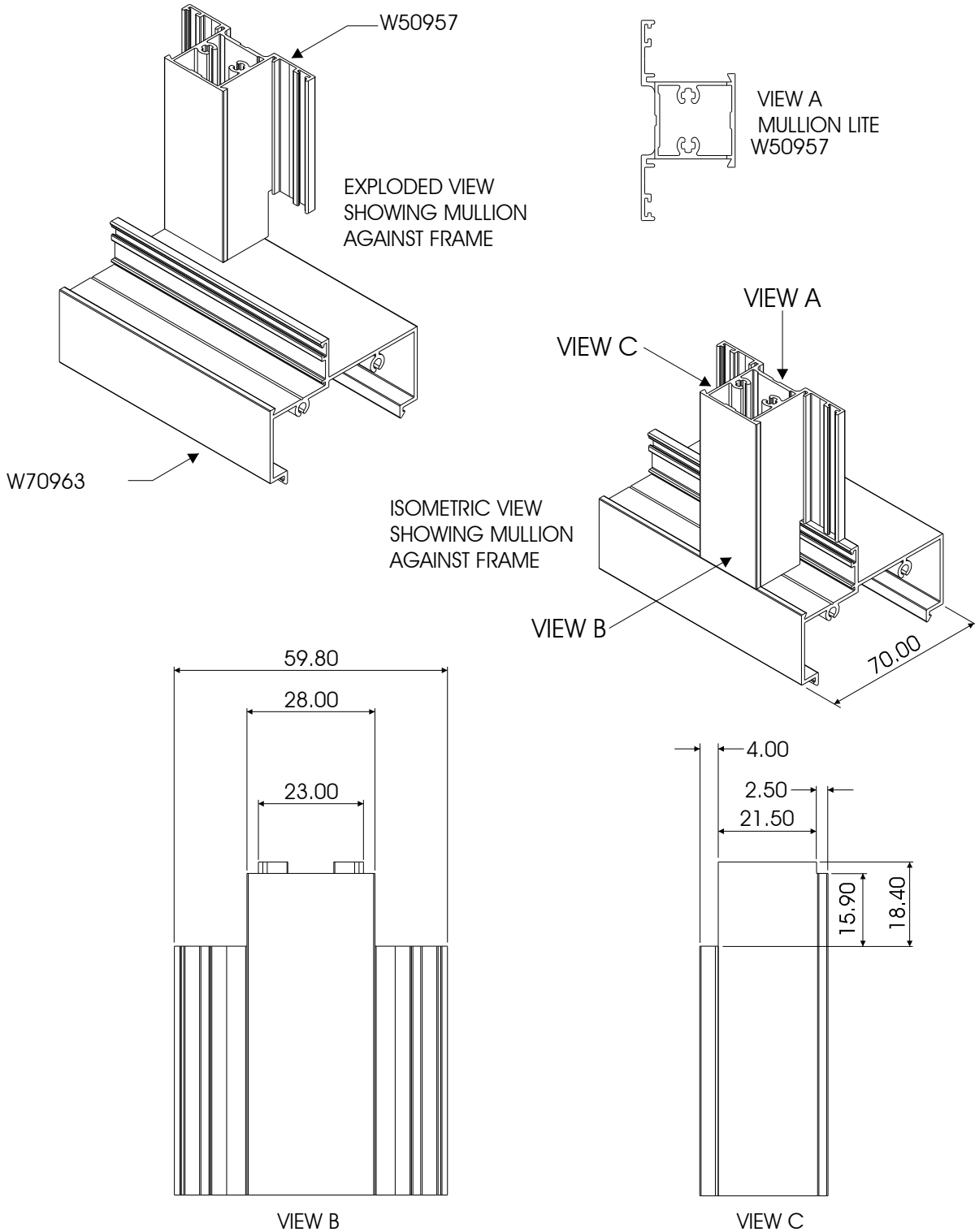

CASEMENT 28
 WINDOW
 LITE MULLION MACHINING DETAIL
 FOR END MILLING ON TUBULAR
 EQUAL LEG OUTER FRAME

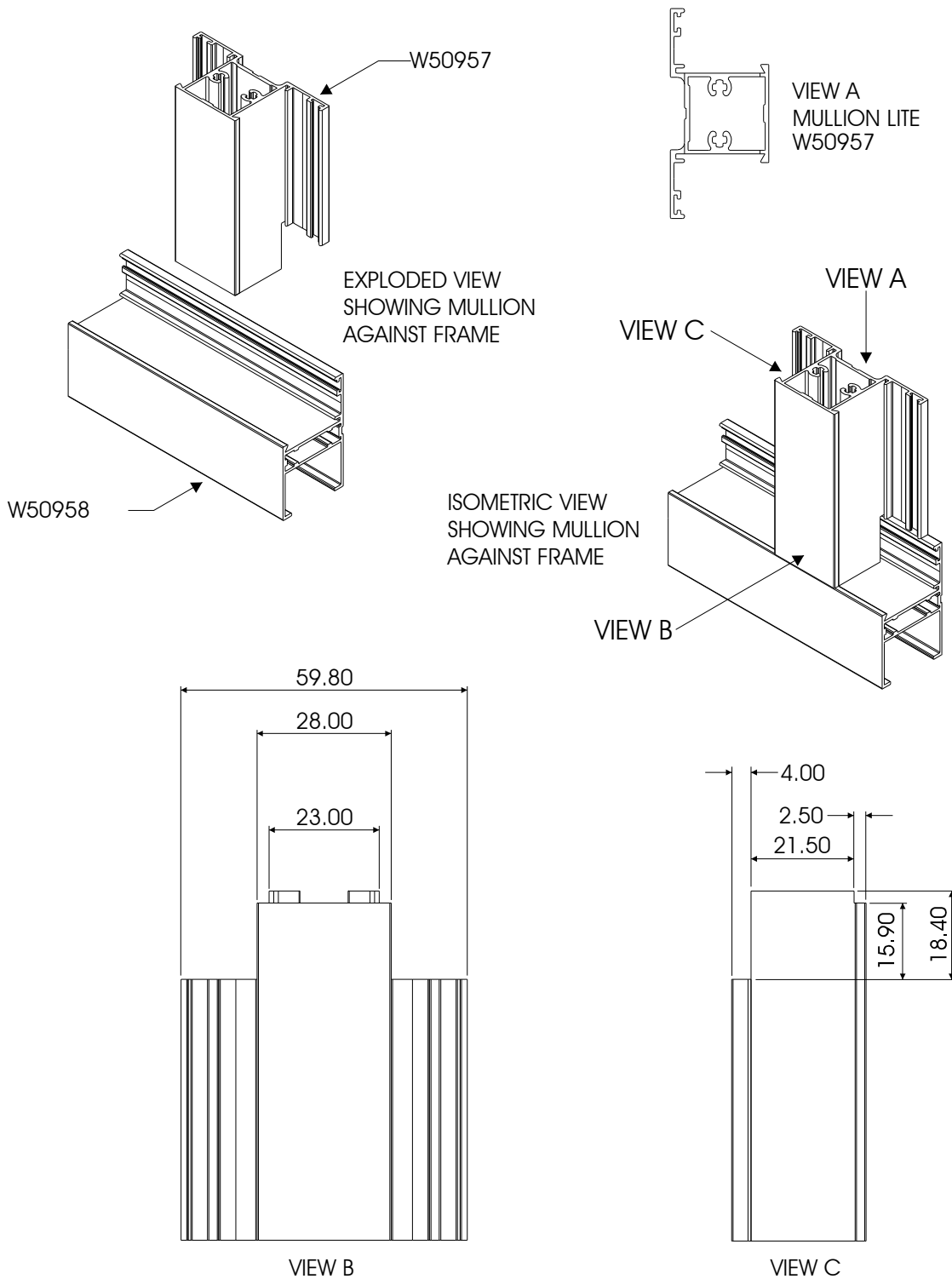

CASEMENT 28
 WINDOW
 CORNER CLEAT ASSEMBLY DETAIL
 FOR TUBULAR SASH

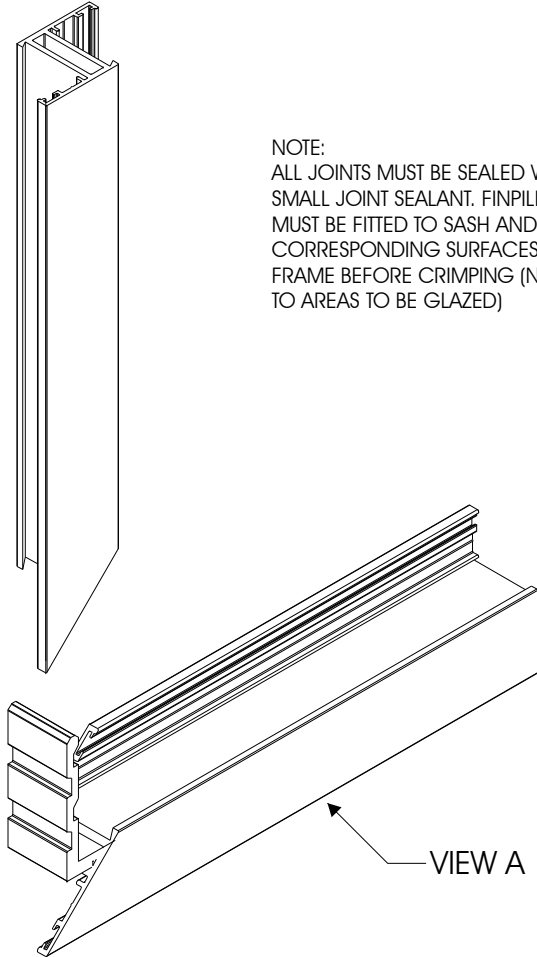

NOTE:
 ALL JOINTS MUST BE SEALED WITH
 SMALL JOINT SEALANT. FINPILE
 MUST BE FITTED TO SASH AND
 CORRESPONDING SURFACES OF
 FRAME BEFORE CRIMPING (NOT
 TO AREAS TO BE GLAZED)

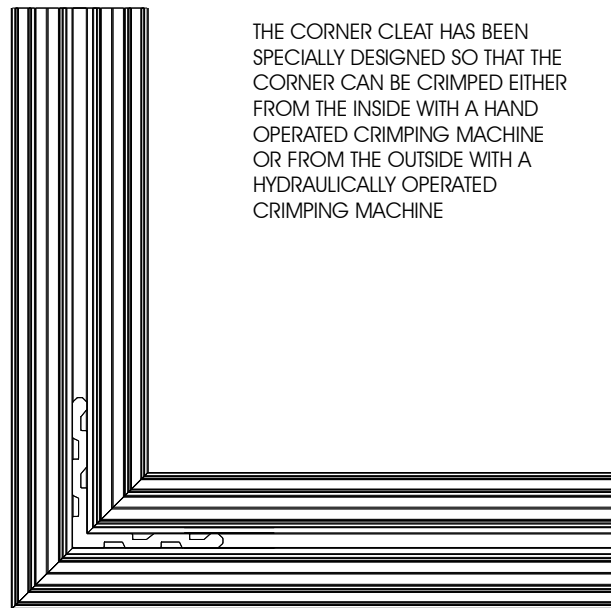
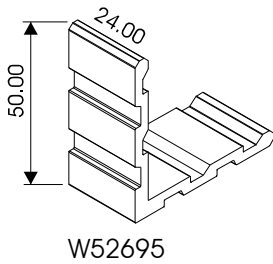
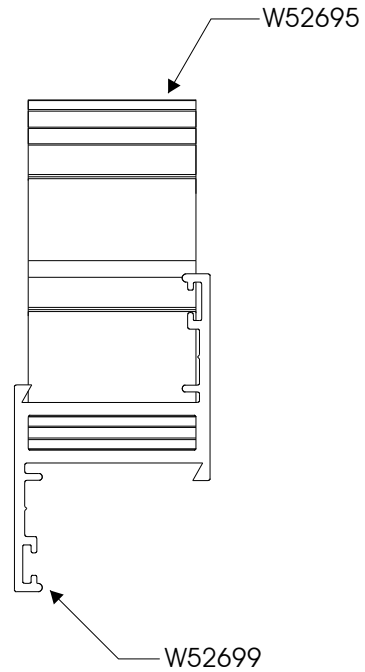

THE CORNER CLEAT HAS BEEN
 SPECIALLY DESIGNED SO THAT THE
 CORNER CAN BE CRIMPED EITHER
 FROM THE INSIDE WITH A HAND
 OPERATED CRIMPING MACHINE
 OR FROM THE OUTSIDE WITH A
 HYDRAULICALLY OPERATED
 CRIMPING MACHINE

VIEW A

CASEMENT 28
 WINDOW
 CORNER CLEAT ASSEMBLY DETAIL
 FOR LITE SASH

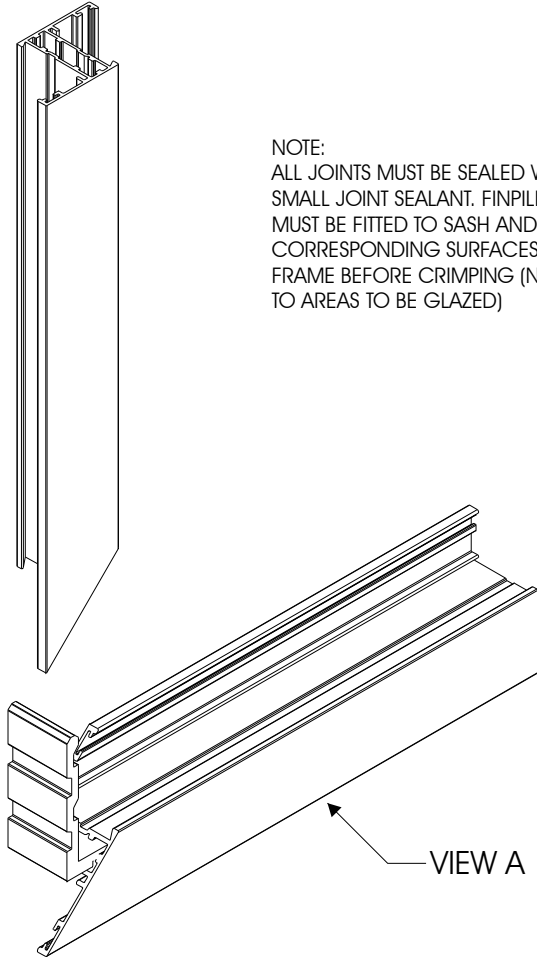

NOTE:
 ALL JOINTS MUST BE SEALED WITH
 SMALL JOINT SEALANT. FINPILE
 MUST BE FITTED TO SASH AND
 CORRESPONDING SURFACES OF
 FRAME BEFORE CRIMPING (NOT
 TO AREAS TO BE GLAZED)

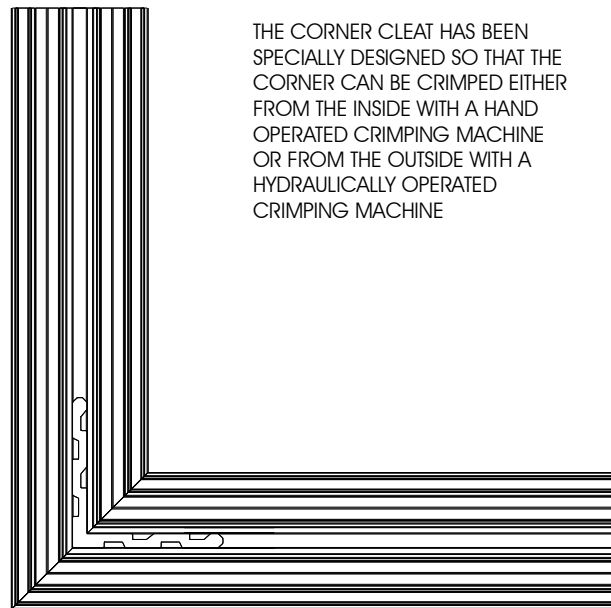
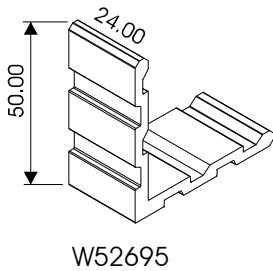
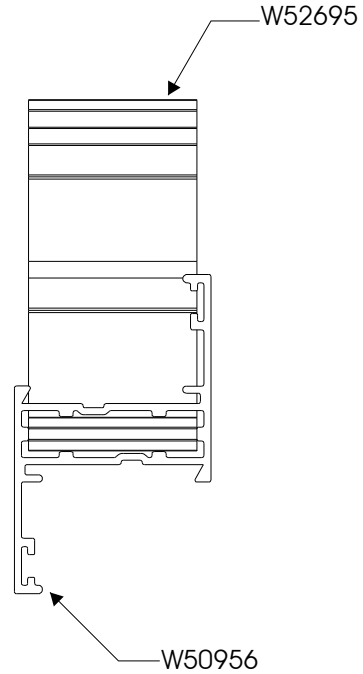

THE CORNER CLEAT HAS BEEN
 SPECIALLY DESIGNED SO THAT THE
 CORNER CAN BE CRIMPED EITHER
 FROM THE INSIDE WITH A HAND
 OPERATED CRIMPING MACHINE
 OR FROM THE OUTSIDE WITH A
 HYDRAULICALLY OPERATED
 CRIMPING MACHINE

VIEW A

CASEMENT 28 WINDOW CROSS JOINT ASSEMBLY DETAIL STANDARD MULLION



NOTE: ALL JOINTS MUST BE SEALED WITH SMALL JOINT SEALANT. FINPILE MUST BE FITTED PRIOR TO ASSEMBLY IF SASH IS TO BE FITTED INTO FRAME. FINPILE MUST NOT RUN BEHIND GLAZING BAR AND GAP MUST BE SEALED TO PREVENT WATER INFILTRATION.

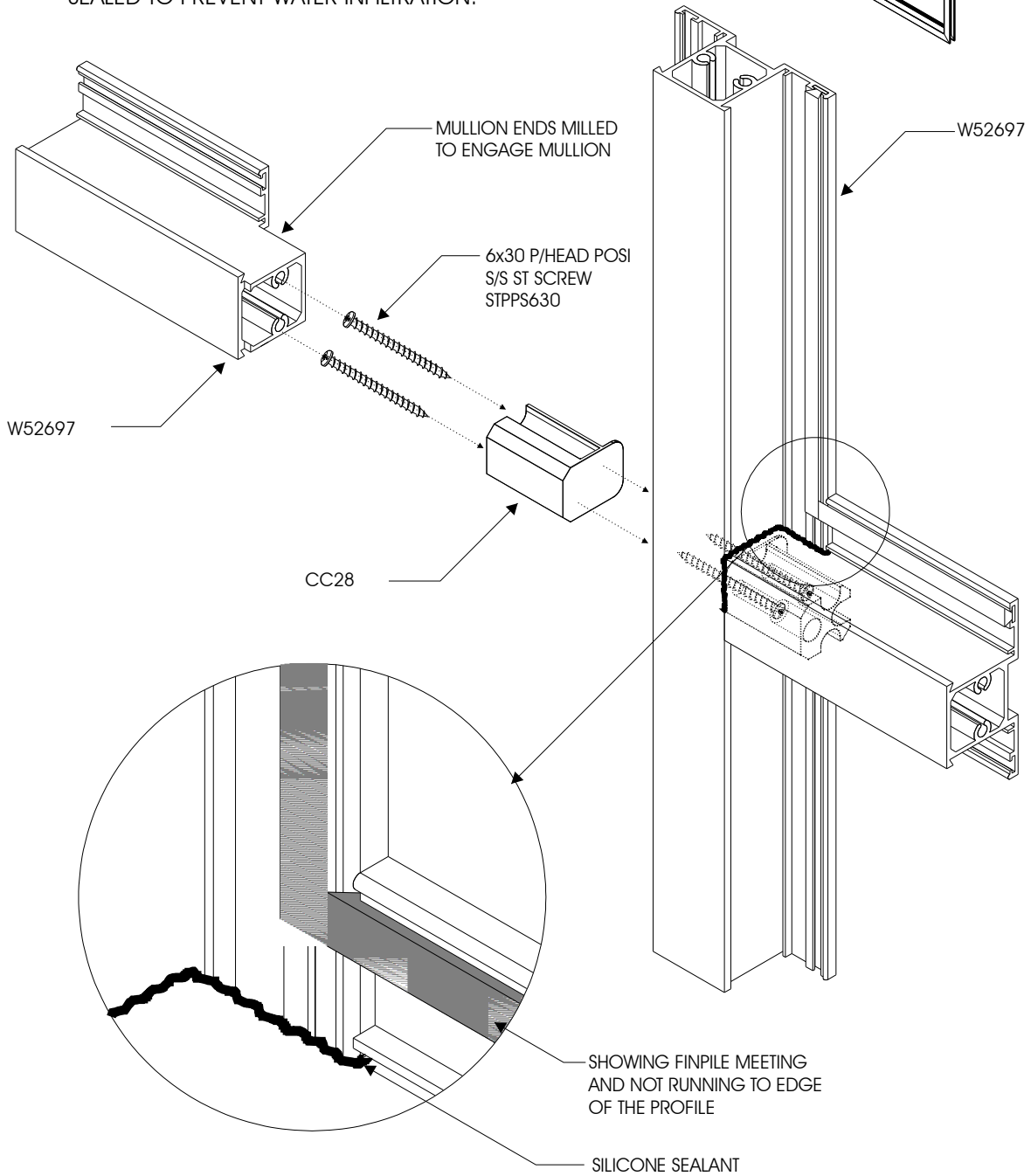
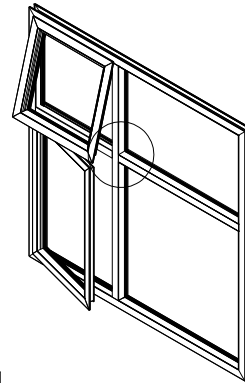

CASEMENT 28 WINDOW CROSS JOINT ASSEMBLY DETAIL LITE MULLION



NOTE: ALL JOINTS MUST BE SEALED WITH SMALL JOINT SEALANT. FINPILE MUST BE FITTED PRIOR TO ASSEMBLY IF SASH IS TO BE FITTED INTO FRAME. FINPILE MUST NOT RUN BEHIND GLAZING BAR AND GAP MUST BE SEALED TO PREVENT WATER INFILTRATION.

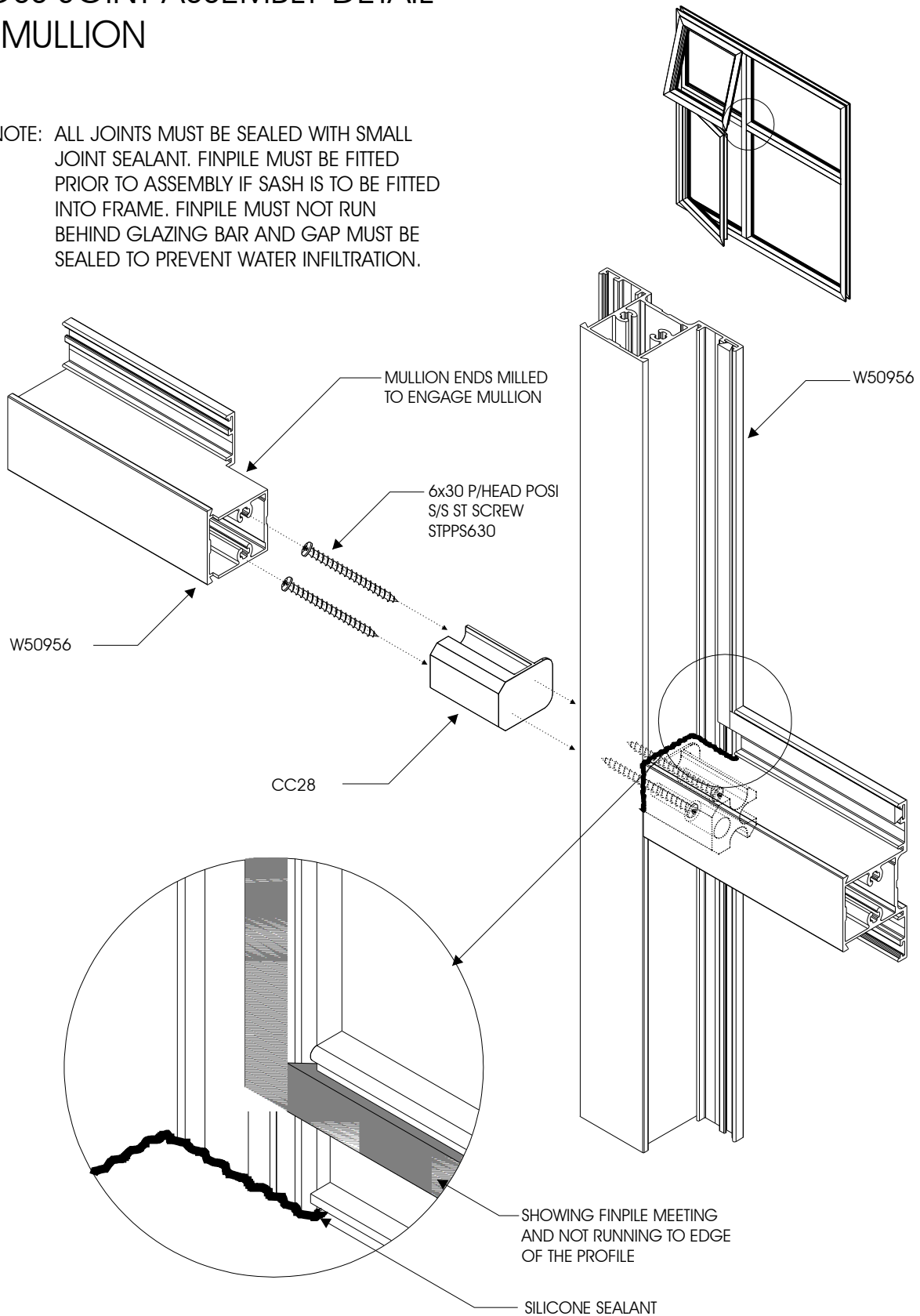

CASEMENT 28
 WINDOW
 CROSS JOINT ASSEMBLY DETAIL
 COTTAGE PANE MULLION

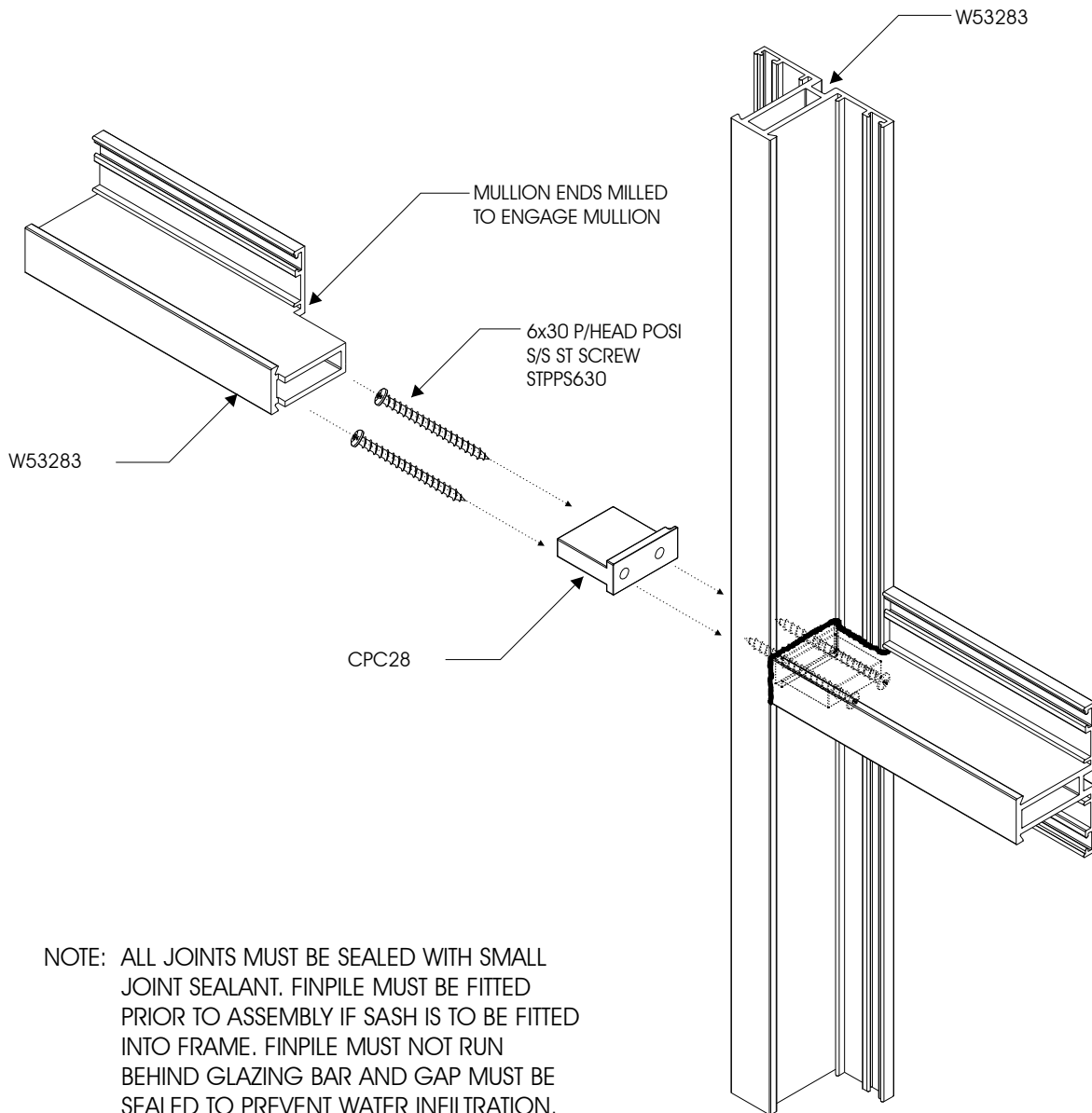

CASEMENT 28 WINDOW GLAZING PROCEDURE

Insert the pull-in vinyl gasket into glazing beads by sliding or pressing it into the groove (1). Before cutting gasket, ensure that it has not stretched and cut 6mm longer so that corners are in compression at all times.

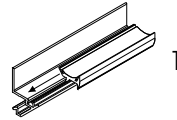

Position bottom glazing bead in glazing bead rebate (2).

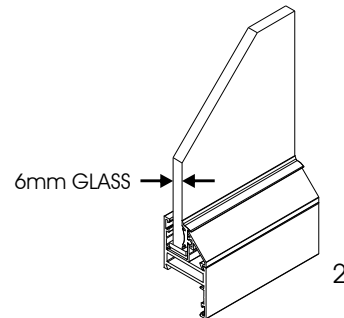

Place glass on glazing blocks (3).

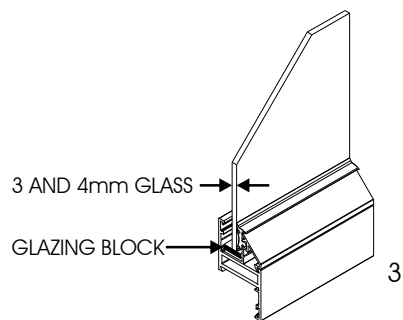

Insert top and then side glazing beads ensuring that they are in correctly.

Starting from top centre, insert roll in gasket (4) without stretching it (5). Stop 150mm from corner and partly cut gasket 6mm longer than the edge of the vertical bead. Insert gasket at corner and then roll in remaining 150mm. Repeat this on the other sides. Where gasket ends meet, cut gasket 6mm longer. Insert cut ends first and complete.

ENSURE GASKETS ARE NOT STRETCHED AT ANY STAGE

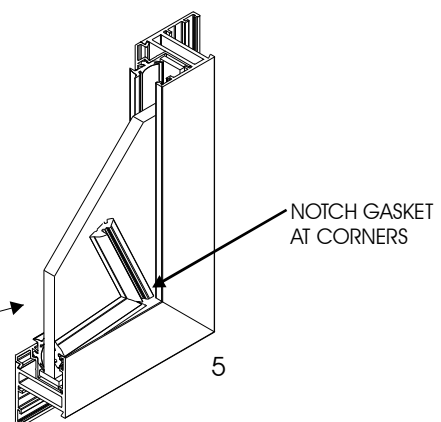
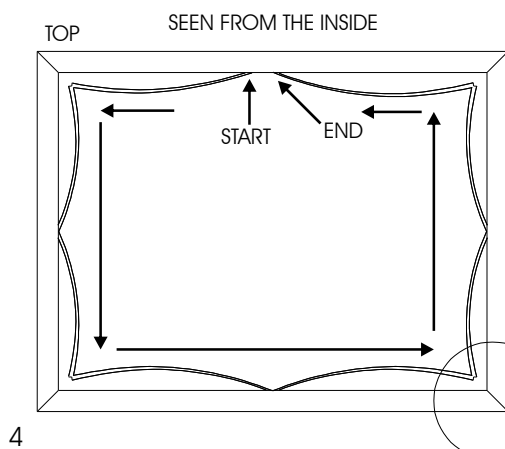

CASEMENT 28 WINDOW GLAZING PROCEDURE

GLAZING

1. SELECTION OF GLAZING METHODS

1.1 SETTING AND LOCATION BLOCKS

Glass-to-metal contact must be avoided at all times by using setting and location blocks having a hardness of 50° to 90° shore A durometer. Use only blocks made of Neoprene, EPDM, Silicone or other elastomeric material.

Setting blocks are to have a minimum thickness of 3mm and must be at least 27mm in length per square metre of glass area.

The position of the setting and location blocks is illustrated in Figure 2.

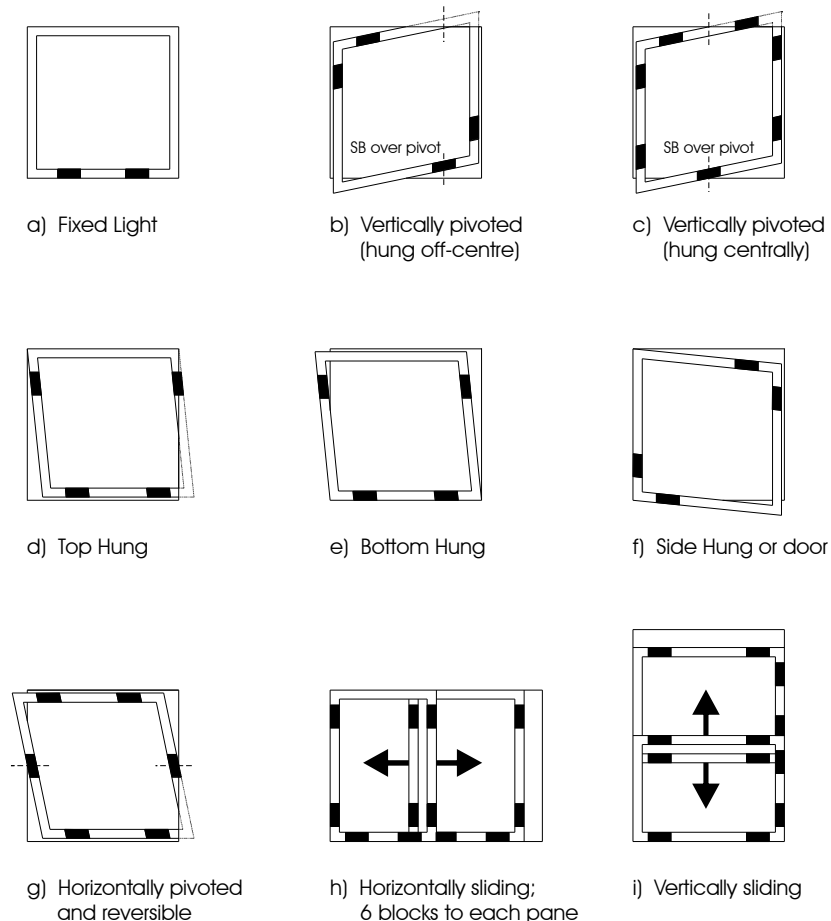
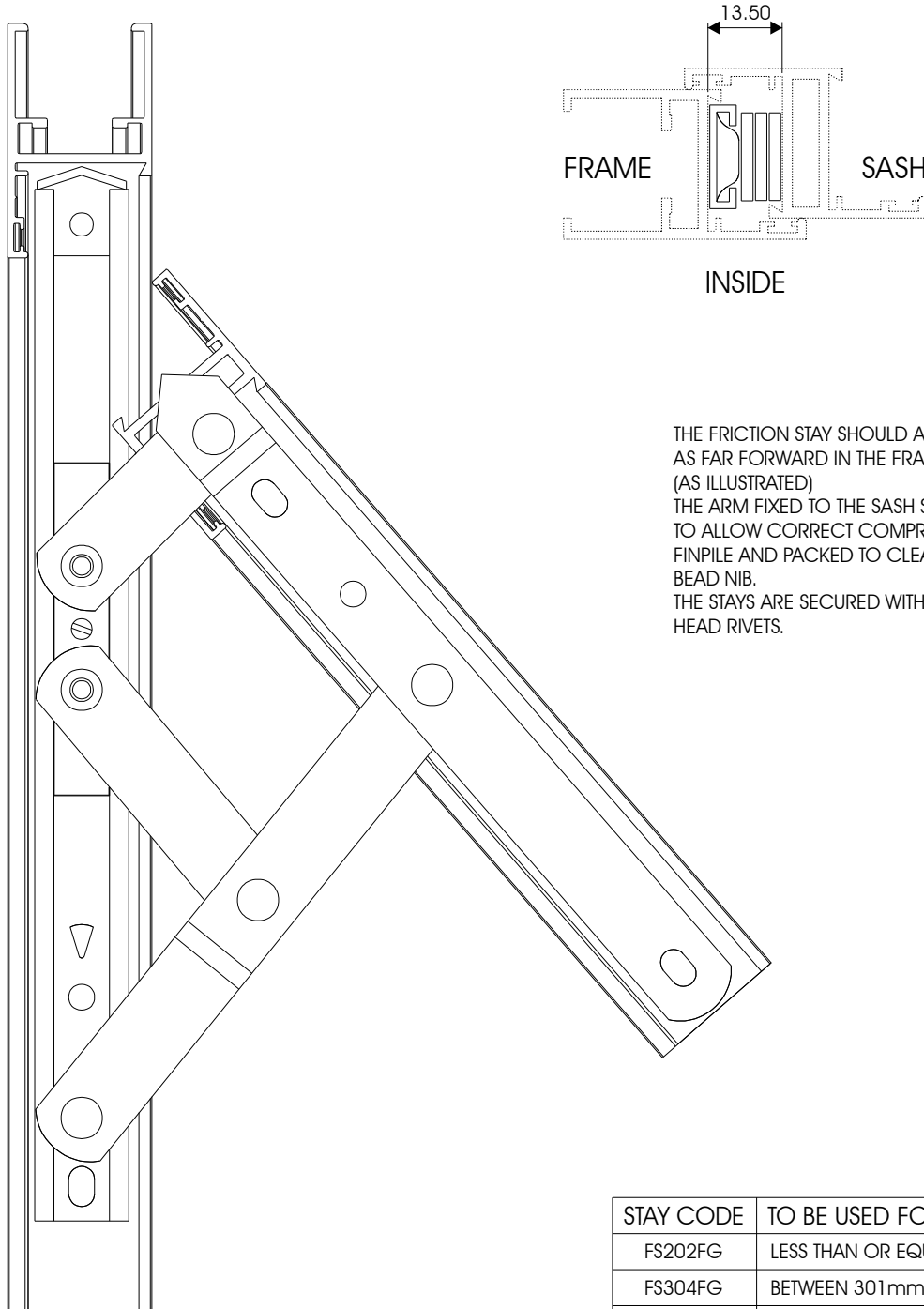

FIGURE 2 - POSITION OF SETTING AND LOCATION BLOCKS

CASEMENT 28
WINDOW
FRICTION STAY ASSEMBLY DETAIL



THE FRICTION STAY SHOULD ALWAYS BE FITTED AS FAR FORWARD IN THE FRAME AS POSSIBLE. (AS ILLUSTRATED)
THE ARM FIXED TO THE SASH SHOULD BE FITTED TO ALLOW CORRECT COMPRESSION OF THE FINPILE AND PACKED TO CLEAR GLAZING BEAD NIB.
THE STAYS ARE SECURED WITH 4.8 x 10 DOME HEAD RIVETS.

STAY CODE	TO BE USED FOR SASH SIZE
FS202FG	LESS THAN OR EQUAL TO 300mm
FS304FG	BETWEEN 301mm AND 450mm
FS406FG	BETWEEN 451mm AND 600mm
FS508FG	BETWEEN 601mm AND 750mm
FS600FG	GREATER THAN 750mm

CASEMENT 28
WINDOW
HANDLE ASSEMBLY DETAIL

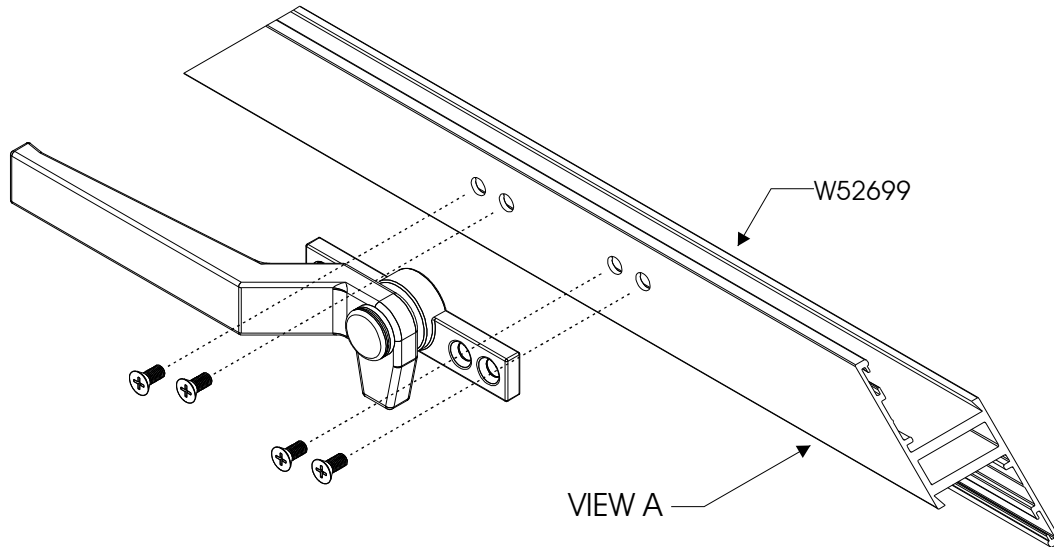

NO 8 x 10 COUNTERSUNK SELF-TAPPING
FLAT END SCREWS

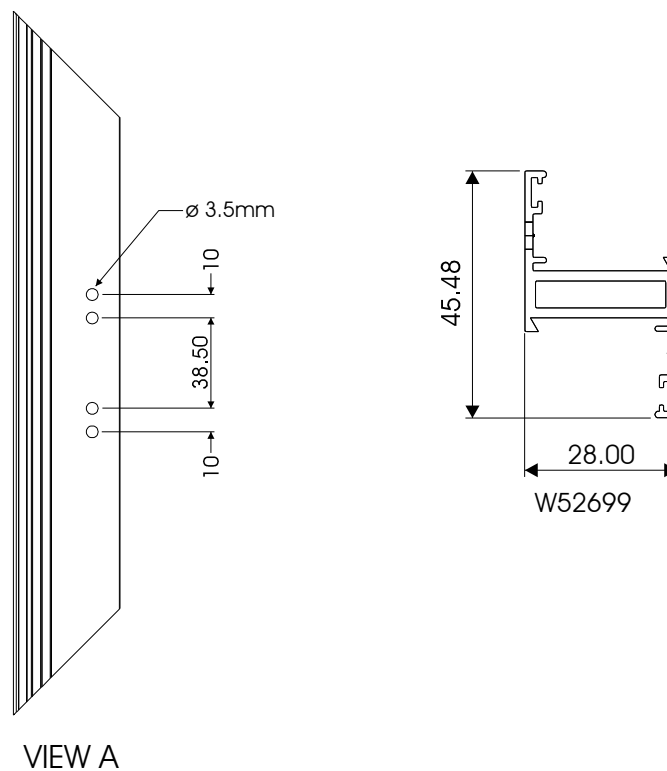

CASEMENT 28
WINDOW
FIXING LUG PREPARATION DETAIL

